

DX100 OPTIONS INSTRUCTIONS

FOR INFORM LANGUAGE

Upon receipt of the product and prior to initial operation, read these instructions thoroughly, and retain for future reference.

MOTOMAN INSTRUCTIONS

- DX100 INSTRUCTIONS
- DX100 OPERATOR'S MANUAL
- DX100 MAINTENANCE MANUAL

The DX100 operator's manual above corresponds to specific usage.
Be sure to use the appropriate manual.

Part Number: 155493-1CD
Revision: 3



MANDATORY

- This manual explains the INFORM language of the DX100 system. Read this manual carefully and be sure to understand its contents before handling the DX100.
- General items related to safety are listed in the Chapter 1: Safety of the DX100 Instructions. To ensure correct and safe operation, carefully read the DX100 Instructions before reading this manual.



CAUTION

- Some drawings in this manual are shown with the protective covers or shields removed for clarity. Be sure all covers and shields are replaced before operating this product.
- The drawings and photos in this manual are representative examples and differences may exist between them and the delivered product.
- Yaskawa Motoman may modify this model without notice when necessary due to product improvements, modifications, or changes in specifications. If such modification is made, the manual number will also be revised.
- If your copy of the manual is damaged or lost, contact a Yaskawa Motoman representative to order a new copy. The representatives are listed on the back cover. Be sure to tell the representative the manual number listed on the front cover.
- Yaskawa Motoman is not responsible for incidents arising from unauthorized modification of its products. Unauthorized modification voids your product's warranty.

NOTES FOR SAFE OPERATION

Read this manual carefully before installation, operation, maintenance, or inspection of the DX100.

In this manual, the Notes for Safe Operation are classified as “WARNING”, “CAUTION”, “MANDATORY”, or “PROHIBITED”.



WARNING

Indicates a potentially hazardous situation which, if not avoided, could result in death or serious injury to personnel.



CAUTION

Indicates a potentially hazardous situation which, if not avoided, could result in minor or moderate injury to personnel and damage to equipment. It may also be used to alert against unsafe practices.



MANDATORY

Always be sure to follow explicitly the items listed under this heading.



PROHIBITED

Must never be performed.

Even items described as “CAUTION” may result in a serious accident in some situations. At any rate, be sure to follow these important items.



To ensure safe and efficient operation at all times, be sure to follow all instructions, even if not designated as “CAUTION” and “WARNING”.



WARNING

- Before operating the manipulator, check that servo power is turned OFF when the emergency stop buttons on the front door of the DX100 and programming pendant are pressed. When the servo power is turned OFF, the SERVO ON LED on the programming pendant is turned OFF.

Injury or damage to machinery may result if the emergency stop circuit cannot stop the manipulator during an emergency. The manipulator should not be used if the emergency stop buttons do not function.

Figure 1: Emergency Stop Button



- Once the emergency stop button is released, clear the cell of all items which could interfere with the operation of the manipulator. Then turn the servo power ON.

Injury may result from unintentional or unexpected manipulator motion.

Figure 2: Release of Emergency Stop

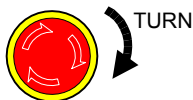

- Observe the following precautions when performing teaching operations within the P-point maximum envelope of the manipulator:
 - View the manipulator from the front whenever possible.
 - Always follow the predetermined operating procedure.
 - Keep in mind the emergency response measures against the manipulator's unexpected motion toward you.
 - Ensure that you have a safe place to retreat in case of emergency.

Improper or unintended manipulator operation may result in injury.

- Confirm that no person is present in the P-point maximum envelope of the manipulator and that you are in a safe location before:
 - Turning ON the DX100 power
 - Moving the manipulator with the programming pendant
 - Running the system in the check mode
 - Performing automatic operations

Injury may result if anyone enters the P-point maximum envelope of the manipulator during operation. Always press an emergency stop button immediately if there is a problem. The emergency stop buttons are located on the right of the front door of the DX100 and the programming pendant.



CAUTION

- Perform the following inspection procedures prior to conducting manipulator teaching. If problems are found, repair them immediately, and be sure that all other necessary processing has been performed.
 - Check for problems in manipulator movement.
 - Check for damage to insulation and sheathing of external wires.
- Always return the programming pendant to the hook on the DX100 cabinet after use.

The programming pendant can be damaged if it is left in the manipulator's work area, on the floor, or near fixtures.

- Read and understand the Explanation of the Warning Labels in the DX100 Instructions before operating the manipulator.

Definition of Terms Used Often in This Manual

The MOTOMAN is the YASKAWA industrial robot product.

The MOTOMAN usually consists of the manipulator, the controller, the programming pendant, and manipulator cables.

In this manual, the equipment is designated as follows:

Equipment	Manual Designation
DX100 Controller	DX100
DX100 Programming Pendant	Programming Pendant
Cable between the manipulator and the controller	Manipulator Cable

Descriptions of the programming pendant keys, buttons, and displays are shown as follows:

Equipment		Manual Designation
Programming Pendant	Character Keys	The keys which have characters printed on them are denoted with []. ex. [ENTER]
	Symbol Keys	The keys which have a symbol printed on them are not denoted with [] but depicted with a small picture. ex. page key  The cursor key is an exception, and a picture is not shown.
	Axis Keys Numeric Keys	“Axis Keys” and “Numeric Keys” are generic names for the keys for axis operation and number input.
	Keys pressed simultaneously	When two keys are to be pressed simultaneously, the keys are shown with a “+” sign between them, ex. [SHIFT]+[COORD]
	Displays	The menu displayed in the programming pendant is denoted with { }. ex. {JOB}

Description of the Operation Procedure

In the explanation of the operation procedure, the expression "Select •••" means that the cursor is moved to the object item and the SELECT key is pressed.

Registered Trademark

In this manual, names of companies, corporations, or products are trademarks, registered trademarks, or brand names for each company or corporation. The indications of (R) and TM are omitted.

Table of Contents

1	Outline of INFORM	1-1
1.1	About INFORM	1-1
1.1.1	INFORM III	1-1
1.1.2	Type of Instruction	1-1
1.1.3	Instruction Set	1-1
1.1.3.1	Selecting Instruction Set	1-2
1.1.4	Variables to be Used in Instructions	1-3
1.1.4.1	Set Value of Variable and Numeric Data	1-3
1.2	Registration of Instructions	1-4
1.2.1	Registration	1-4
1.2.2	Learning Function	1-5
1.3	Detail Edit Window	1-6
1.4	Registration of Expression	1-7
1.4.1	Expression	1-7
1.4.2	Registration	1-9
1.5	INFORM Structure	1-11
1.5.0.1	Example of Structure	1-11
1.5.0.2	INFORM Structure Elements	1-12
1.5.0.3	Meaning of INFORM Structure	1-12
1.5.0.4	Explanation Table	1-13
2	INFORM Explanation	2-1
2.1	I/O Instructions	2-1
	DOUT	2-1
	DIN	2-4
	WAIT	2-7
	PULSE	2-11
	AOUT	2-14
	ARATION	2-15
	ARATIOF	2-19
	ANTOUT	2-20
2.2	Control Instruction	2-25
	JUMP	2-25
	CALL	2-29
	GETARG	2-41
	TIMER	2-43
	*(LABEL)	2-44
	'(COMMENT)	2-45
	RET	2-46
	NOP	2-49
	PAUSE	2-50

Table of Contents

CWAIT	2-51
MSG	2-52
ADVINIT	2-53
ADVSTOP	2-54
PRINT	2-55
CLS	2-59
ABORT	2-60
SETUALM	2-61
DIALOG	2-63
DIALSB.....	2-67
2.3 Operating Instruction.....	2-70
CLEAR	2-70
INC	2-74
DEC.....	2-76
SET	2-78
ADD.....	2-86
SUB	2-93
MUL.....	2-100
DIV	2-107
CNVRT	2-114
AND.....	2-117
OR.....	2-119
NOT	2-121
XOR.....	2-123
MFRAME.....	2-125
SETE	2-127
GETE.....	2-129
GETS.....	2-131
SQRT	2-136
SIN	2-138
COS.....	2-140
ATAN.....	2-142
MULMAT	2-144
INVMAT.....	2-146
SETFILE.....	2-147
GETFILE	2-150
SETREG.....	2-152
GETREG	2-153
GETPRM	2-154
SETPRM	2-156

Table of Contents

2.4	Move Instruction	2-158
	MOVJ	2-158
	MOVL	2-168
	MOVC	2-177
	MOVS	2-187
	IMOV	2-195
	SPEED	2-202
	REFP	2-205
2.5	Shift Instruction	2-211
	SFTON	2-211
	SFTOF	2-215
	MSHIFT	2-217
2.6	Instruction Which Adheres to an Instruction	2-219
	IF	2-219
	UNTIL	2-228
	ENWAIT	2-230
2.7	Arc Welding Instruction	2-231
	ARCON	2-231
	ARCOF	2-236
	VWELD	2-240
	AWELD	2-242
	ARCSET	2-244
	WVON	2-247
	WVOF	2-252
	ARCCTS	2-254
	ARCCTE	2-258
2.8	Handling Instruction	2-262
	HAND	2-262
	HSEN	2-264
2.9	Spot Welding Instruction	2-266
	GUNCL	2-266
	SPOT	2-268
	STROKE	2-271
	STRWAIT	2-272
2.10	General-purpose Instruction	2-273
	TOOLON	2-273
	TOOLOF	2-274

1 Outline of INFORM

1.1 About INFORM

1.1.1 INFORM III

The robot programming language used with DX100 is called INFORM III. INFORM III is composed of the instruction and the additional item (tag and numeric data).

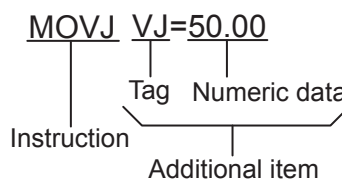

- **Instruction:** It is used to execute the operation and processing. In the case of a move instruction, when a position is taught, the move instruction is automatically displayed according to the interpolation method.
- **Additional item:** The speed, time, etc. are set according to the type of instruction. Numeric data and character data are added to the tag that specifies the condition as necessary.

1.1.2 Type of Instruction

The instruction is divided into several types in terms of each process and operation.

Type	Content	Instruction Example
I/O Instruction	It is the instruction used to control the I/O.	DOUT, WAIT
Control Instruction	It is the instruction used to control the processing and operation.	JUMP, TIMER
Operating Instruction	It is the instruction by which the variables, etc. are used and operated.	ADD, SET
Move Instruction	It is an instruction concerning the movement and the speed.	MOVJ, REFP
Shift Instruction	It is an instruction used when a present teaching position is shifted.	SFTON, SFTOF
Instruction which adheres to instruction	It is an instruction which adheres to the instruction.	IF, UNTIL
Work Instruction	It is an instruction concerning work, such as arc welding and handling.	ARCON, WVON
Optional Instruction	It is an instruction concerning optional functions. It can only be used when the function is available.	-

1.1.3 Instruction Set

To improve operation efficiency, the number of instructions to be registered is limited. All instructions are executed, regardless of the instruction set during playback, etc.

1 Outline of INFORM

1.1 About INFORM

- Subset Instruction Set
Only high instructions which are used frequently are in the subset instruction set. The number of instructions is small, which allows for easier selecting and input.
- Standard Instruction Set / Expanded Instruction Set
All INFORM III instructions can be registered. For these two sets, the number of additional items which can be used by each instruction is different. The following function cannot be used with a standard instruction set, but operation is easier because the number of data decreases when the instruction is registered.
 - Local Variable, Use of Array Variable
 - Use of Variable to Additional Item (Ex.: MOVJ VJ=I000)

1.1.3.1 Selecting Instruction Set

Select an instruction set in the teaching condition window.

1. Select {SETUP} under the main menu
2. Select {TEACHING COND}
 - The teaching condition window appears.

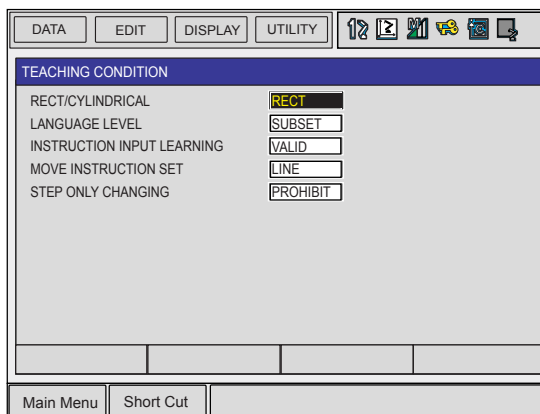

3. Select "LANGUAGE LEVEL"
 - The instruction set selection dialog box appears.

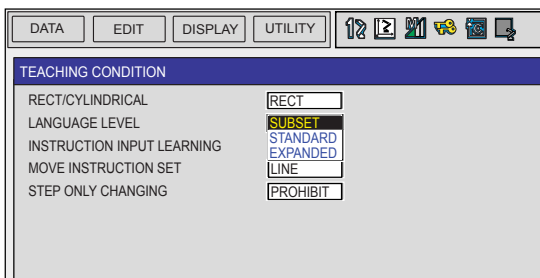

4. Select the language level (instruction set)

- The language level is selected.

DATA	EDIT	DISPLAY	UTILITY					
TEACHING CONDITION								
RECT/CYLINDRICAL		RECT						
LANGUAGE LEVEL		EXPANDED						
INSTRUCTION INPUT LEARNING		VALID						
MOVE INSTRUCTION SET		LINE						
STEP ONLY CHANGING		PROHIBIT						
<div style="display: flex; justify-content: space-between;"> Main Menu Short Cut </div>								

1.1.4 Variables to be Used in Instructions

Variables can be used as numeric data for the additional item of the instructions in the standard and expanded instruction sets.

Also, the instructions in the expanded instruction set can use local variables and array variables.



- The applicable variable differs depending on the additional item.
- The number of local variables to be used must be set in the job header display. For setting the number of local variables, refer to the Operator's Manual "Editing Local Variables".

1.1.4.1 Set Value of Variable and Numeric Data

The unit of the numeric data for the additional item of the instruction decides the set value of variable and the value of the additional item at execution.

< Example >

TIMER tag (T=)

TIMER T=I000

When a variable is used for the numeric data of the TIMER tag, the unit of numeric data is 0.01 seconds.

When 1000 is set for I000, the value when the instruction is executed is 10.00 seconds.

1.2 Registration of Instructions

1.2.1 Registration

Press [INFORM LIST]  while the job content window is shown to register instructions.

1. Select {JOB} under the main menu
2. Select {JOB}
 - The job content window appears.
3. Press [INFORM LIST]
 - The job instruction group list dialog box appears.

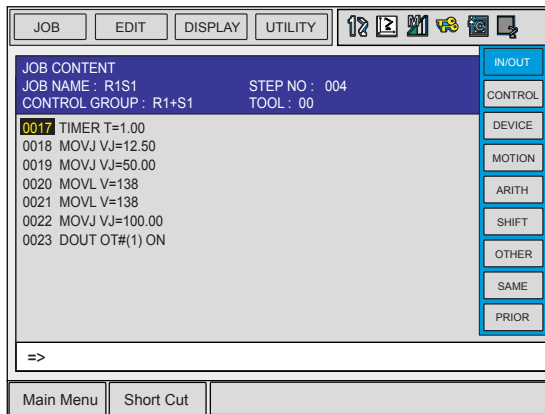

4. Select the desired instruction group
 - The job instruction group list dialog box appears.

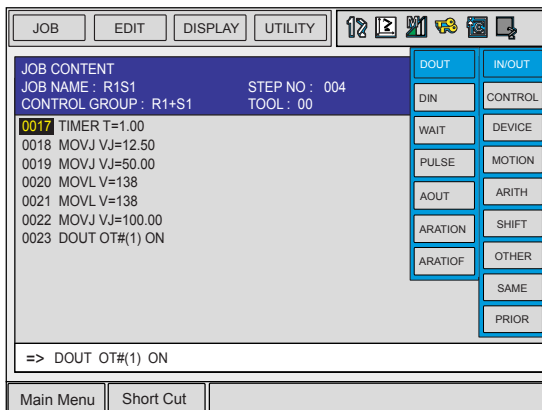
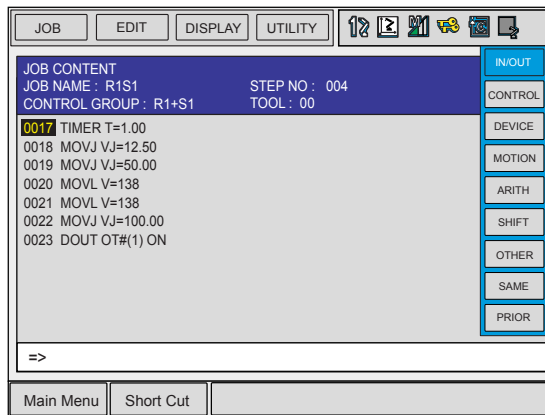

1 Outline of INFORM

1.2 Registration of Instructions

5. Select the desired instruction
 - The instruction is displayed in the input buffer line.
6. Press [ENTER]
 - The instruction displayed in the input buffer line is registered in the job.
 - Also, if the instruction must be registered during the job, press [INSERT] before pressing [ENTER].



Refer to the *Operator's Manual* "5.2 Editing Instructions" for details on editing instructions.

1.2.2 Learning Function

With the learning function, an instruction can be registered with the same additional items as those previously registered with the instruction.

Validate the learning function to minimize the number of instruction registries.

Set the learning function to valid or invalid in the teaching condition window.

1. Select {SETUP} under the main menu
2. Select {TEACHING COND}
 - The teaching condition window appears.

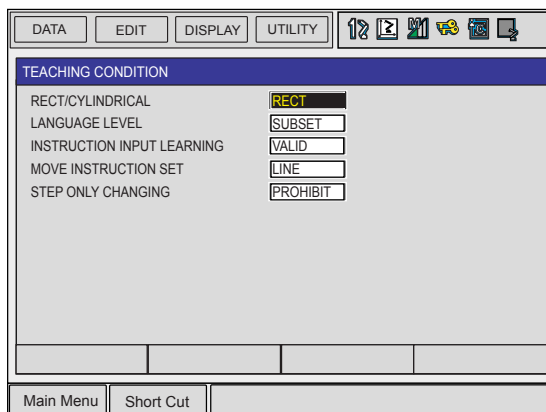

3. Move the cursor to "INSTRUCTION INPUT LEARNING".
 - The condition "VALID" or "INVALID" is switched each time [SELECT] is pressed.

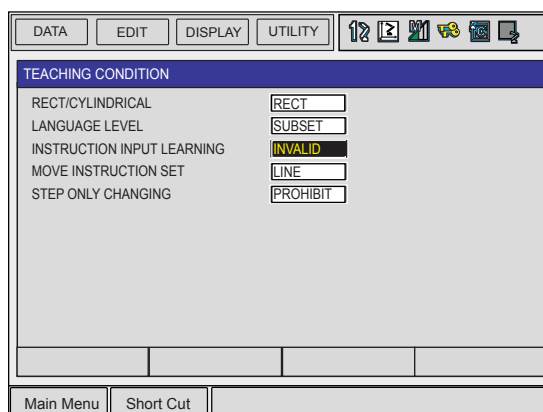

1.3 Detail Edit Window

All instructions have a detail edit window.

The detail edit window is used for adding, modifying, and deleting additional items in the instruction.

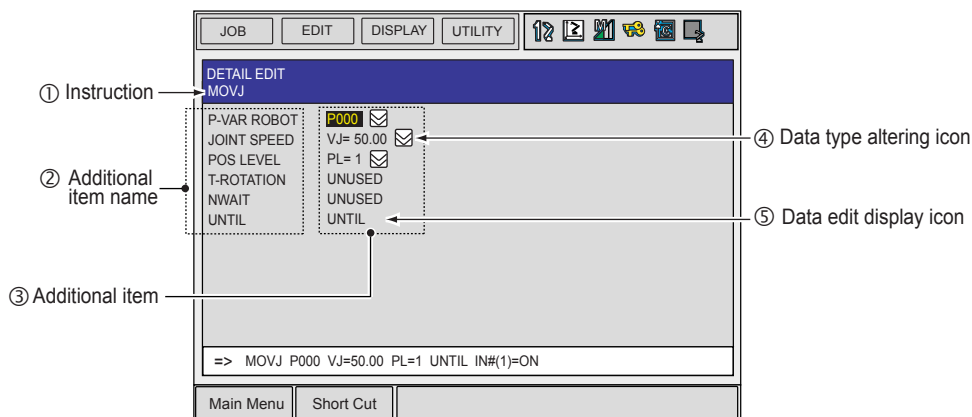

① Instructions

Indicates the instruction.

② Additional Item Name

Indicates the name of the additional item (type).

③ Additional Item

Indicates the additional item.

The tag selection dialog box appears when the cursor is on the additional item and [SELECT] is pressed.

When "NOT USED" is selected, the tag is omitted (if it can be omitted).

④ Data Type Altering Icon

Alters the type of numeric data.

For example, if the 50.00 of VJ=50.00 (constant type) is changed to I000 (integer-type variable), it becomes VJ=I000.

⑤ Detail Edit Display Icon

Indicates the detail edit display is shown.

1.4 Registration of Expression

1.4.1 Expression

With INFORM III, an expression can be added to the SET instruction.

< Example >

```

SET B000 ( B001 + B002 ) / B003 - ( B004 + B005 ) * B006

```

|
|

Result stored destination
Expression

Register an expression in the DETAIL EDIT window.



Expressions can be registered only when “STANDARD” or “EXPANDED” has been selected for the language level (instruction set).

The DETAIL EDIT window for expression is shown below.

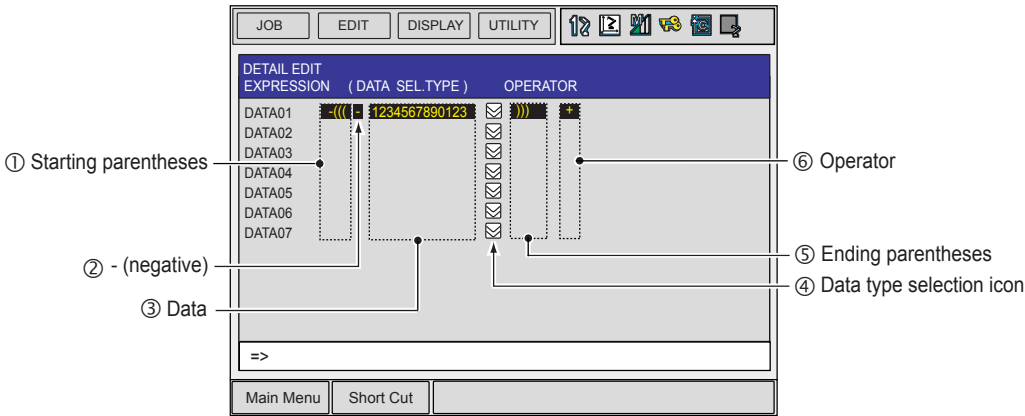

① Starting parentheses

Move the cursor to the parentheses, and press [SELECT]. Each time [SELECT] is pressed, three types of parentheses show up in the following order.

(→ ((→ (((→ -(→ -((→ -(((

②- (negative)

Move the cursor to the desired position, and press [SELECT]. Each time [SELECT] is pressed, the negative is alternately added and omitted and vice versa.

1 Outline of INFORM

1.4 Registration of Expression

③ Data

The data type of the expression is indicated. The following types of data can be registered.

- Constant (byte type, integer type, double-precision type, and real-number type)
- Byte type variable (B, B[], LB, and LB[])
Integer type variable (I, I[], LI, and LI[])
- Double-precision type variable (D, D[], LD, and LD[])
- Real-number type variable (R, R[], LR, and LR[])

Move the cursor to the desired position, and press [SELECT] to enter the numeric value input status. Change the numeric value of the constant data and the variable number.

Change the data type by using the mData type selection icon.

④ Data type selection icon

Change the data type in the following manner.

Move the cursor to the data type to be changed, and press [SELECT].

A dialog box with the selectable data types is displayed. Move the cursor to the data type to be selected and press [SELECT].

⑤ Ending parentheses

Move the cursor to the parentheses and press [SELECT]. Each time [SELECT] is pressed, three types of parentheses show up in the following order.

) →)) →)))

⑥ Operator

Move the cursor to the operator to be changed and press [SELECT].

The operator selection dialog box is displayed. Move the cursor to the operator to be selected and press [SELECT].

< Example of the DETAIL EDIT display for expression >

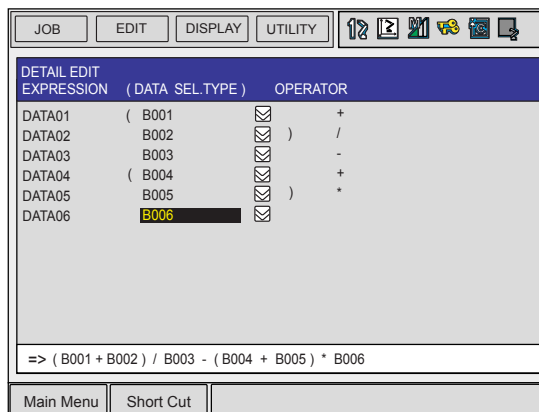
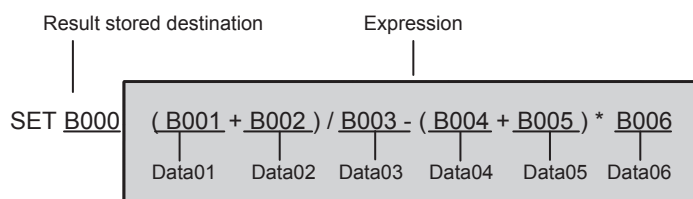

1.4.2 Registration

1. Select {JOB} under the main menu
2. Select {JOB}
3. Press [INFORM LIST]
4. Select "ARITH"
5. Select "SET"
6. Press [SELECT]
 - The DETAIL EDIT window for the SET instruction appears.

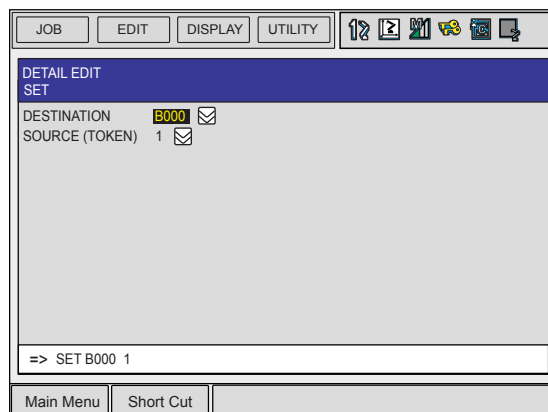

7. Move the cursor to the button beside "SOURCE(TOKEN)"
 - The selection dialog box appears.

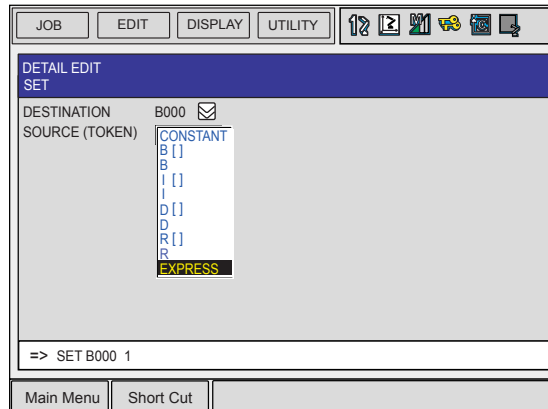

1 Outline of INFORM

1.4 Registration of Expression

8. Select "EXPRESS"

- The DETAIL EDIT window for expression appears.

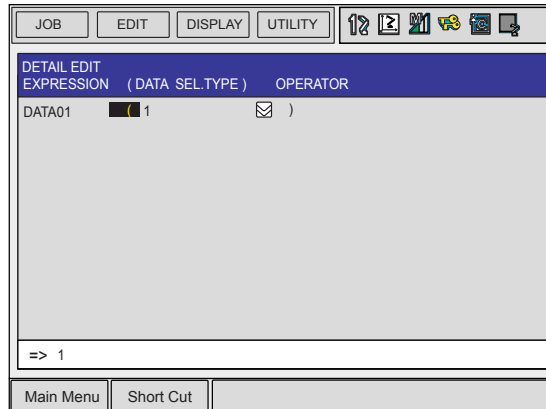

9. Enter the expression and press [ENTER]

- The DETAIL EDIT window for the SET instruction appears.

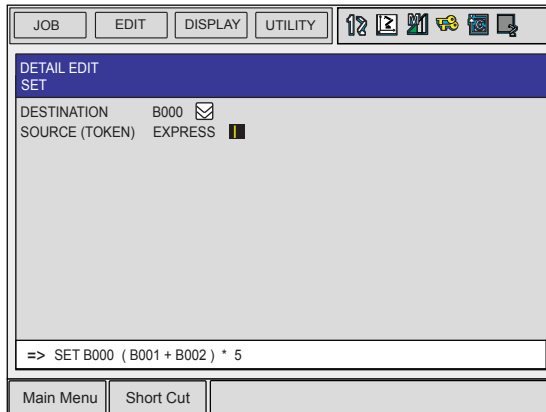

10. Press [ENTER]

- The JOB CONTENT window appears.

11. Press [ENTER]

- The SET instruction indicated in the input buffer line is registered.

1.5 INFORM Structure



An example of the INFORM structure is shown in the following structure flowchart.

The INFORM structure chart is composed of the structure elements (instruction, tag, and data). The order of the rows is shown with the numbers and arrows.

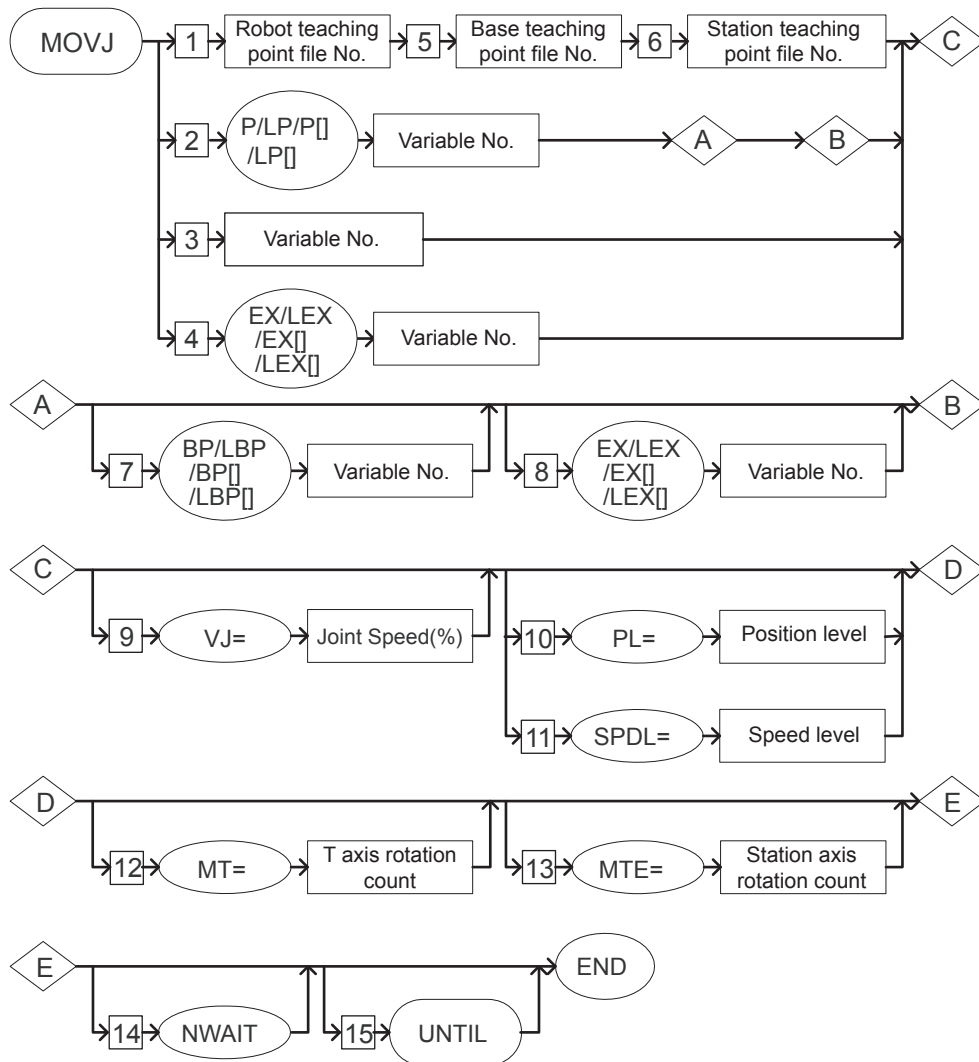
1.5.0.1 Example of Structure

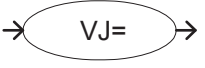
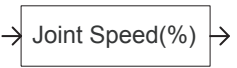

1.5.0.2 INFORM Structure Elements

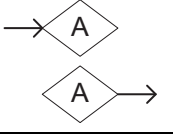
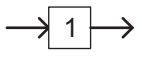
INFORM Structure Element	Explanation	Note
	Indicates the instruction.	In this example, the "MOVJ" instruction is indicated.
	Indicates the tag.	In this example, the "VJ=" instruction is indicated.
	Indicates the numeric data.	In this example, "Joint speed" is set with the unit %.
	Indicates the end of the instruction.	
	Indicates the connection.	
	Indicates the tag order.	

1.5.0.3 Meaning of INFORM Structure

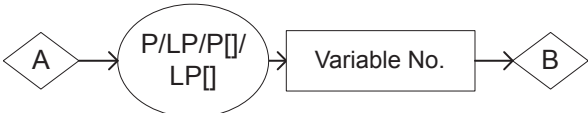
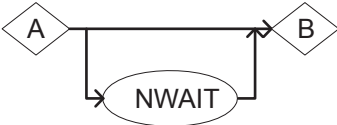
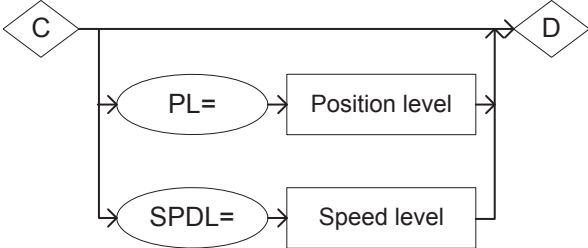
INFORM Structure	Meaning
	This is an indispensable tag. In this example, it is necessary to add a tag from [P Variable /LP Variable /P Array /LP Array].
	This is a tag that can be omitted. In this example, the NWAIT tag can be omitted.
	This is a tag that can be selected. In this example, either PL= tag or SPDL= tag can be selected.

DX100

1 Outline of INFORM
1.5 INFORM Structure

1.5.0.4 Explanation Table

The explanation table in this manual can be described as follows.

No	Tag	Explanation	Note
1	OT # (Output number)	Specifies the output number signal.	No:1 to 2048 Variable B//D/LB/LI/LD can be used.

- NO.
Indicates the tag number. Corresponds to the number in the INFORM structure.
- Tag
Indicates the surface description of the tag.
- Explanation
Provides an explanation of the tag.

2 INFORM Explanation

2.1 I/O Instructions

DOUT

SUBSET	STANDARD	EXPANDED
Available	Available	Available

Function

Turns the general output signal on and off.

Construction

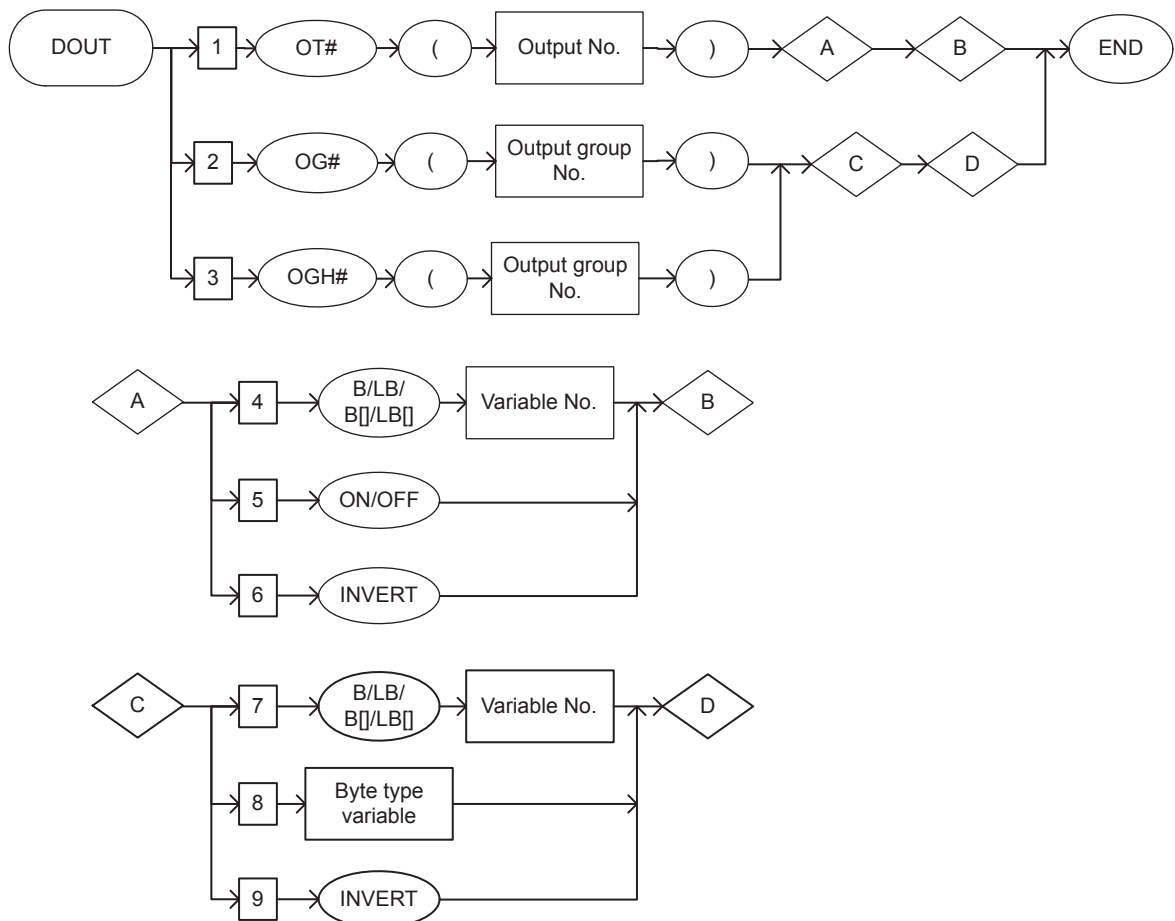

DX100

2 INFORM Explanation

2.1 I/O Instructions

Explanation

1. OT# (Output number) /OG# (Output group number) / OGH# (Output group number)

Choose one of the tags from the following table.

No	Tag	Explanation	Note
1	OT#(Output number)	Specifies the output number signal.	No:1 to 2048 Variable B/I/D/LB/LI/LD can be used.
2	OG#(Output group number)	Specifies the output number group signal (1group 8 points).	No:1 to 256 Variable B/I/D/LB/LI/LD can be used.
3	OGH#(Output group number)	Specifies the output number group signal (1group 4 points).	No:1 to 512 Variable B/I/D/LB/LI/LD can be used.



Output signal

Output signal OT#(xx) is 1 point, OGH#(xx) is 1 group 4 points, and OG#(xx) is 1 group 8 points.

OT#(8)	OT#(7)	OT#(6)	OT#(5)	OT#(4)	OT#(3)	OT#(2)	OT#(1)
OGH#(2)				OGH#(1)			
OG#(1)							

2. OT# (Output number) /OG# (Output group number) / OGH# (Output group number)

When OT# (output number) is selected from the table in part 1 of this Explanation, choose one of the tags from the following table.

No	Tag	Explanation	Note
4	B Variable number/ LB Variable number / B [Array number]/ LB [Array number]	The least significant bit of the specified byte type variable specifies on/off of the output signal.	Least significant bit: 0: OFF 1: ON
5	ON/OFF	Specifies on/off of the output signal.	
6	INVERT	Refers the current signal status to output OFF when the status is ON, and output ON when the status is OFF.	

3. B Variable number / LB Variable number / B [Array number] / LB [Array number] / Byte type constant

When OG# (Output group number) or OGH# (Output group number) is selected from the table in part 1 of this Explanation, choose one of the tags from the following table.

No	Tag	Explanation	Note
7	B Variable number/ LB Variable number/ B [Array number]/ LB [Array number]	Specifies on/off of the output signal by the specified bit value byte type variable.	bit: 0: OFF 1: ON
8	Byte type constant	When the constant byte type is expressed in bit form, the corresponding on/off output signal is specified. Specifies on/off of the output signal by bit value.	
9	INVERT	Refers the current signal status to output OFF when the status is ON, and output ON when the status is OFF.	

Example

- (1) DOUT OT#(12) ON
General output signal no. 12 is turned on.

- (2) SET B000 24
DOUT OG#(3) B000
B000=24(Decimal)= 00011000(Binary)

OT#(24)	OT#(23)	OT#(22)	OT#(21)	OT#(20)	OT#(19)	OT#(18)	OT#(17)
OG#(3)							

ON

General output signals nos. 20 and 21 are turned on.

DIN

SUBSET	STANDARD	EXPANDED
Available	Available	Available

Function

Refers to the byte type variable for the status of the signal.

Construction

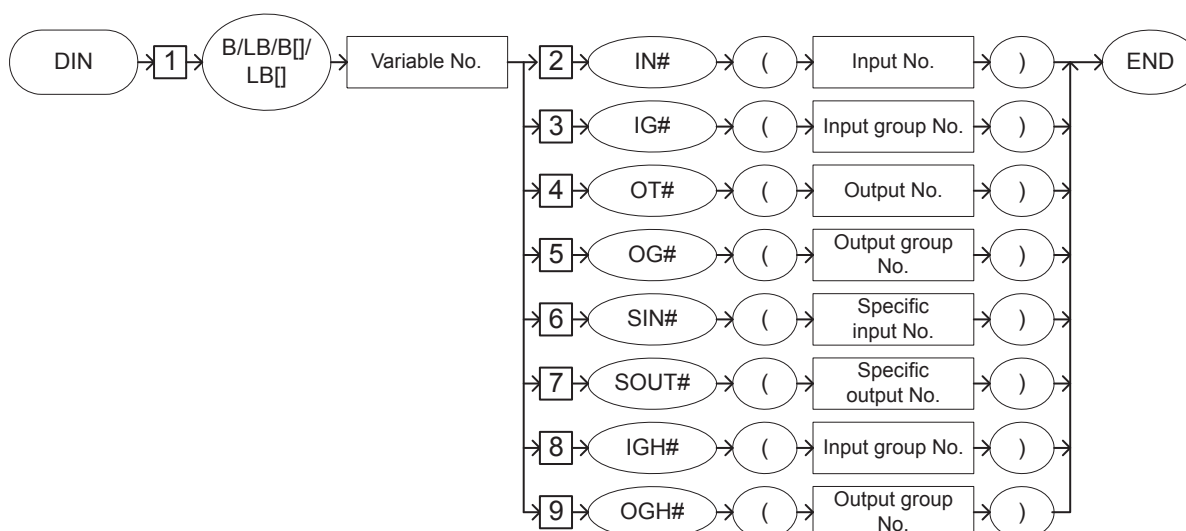

Explanation

1. B Variable Number / LB Variable Number / B [Array Number] / LB [Array Number]

Add the following tag.

No	Tag	Explanation	Note
1	B Variable Number/ LB Variable Number/ B [Array Number]/ LB [Array Number]	Specifies the number of byte type variable for the signal.	

2. IN#(Input number) / IG#(Input group number) / OT#(Output number) / OG#(Output group number) / SIN#(Specific input number) / SOUT#(Specific output number) / IGH#(Input group number) / OGH#(Output group number)

Choose one of the tags from the following table.

No	Tag	Explanation	Note
2	IN#(Input number)	Specifies the general input signal number which shows the signal status.	No:1 to 2048 Variable B//D/LB/LI/LD can be used.
3	IG#(Input group number)	Specifies the general input group signal number (1 group 8 points) which shows the signal status.	No:1 to 256 Variable B//D/LB/LI/LD can be used.
4	OT#(Output number)	Specifies the general output signal number which shows the signal status.	No:1 to 2048 Variable B//D/LB/LI/LD can be used.
5	OG#(Output group number)	Specifies the general output group signal number (1 group 8 points) which shows the signal status.	No:1 to 256 Variable B//D/LB/LI/LD can be used.
6	SIN#(Specific input number)	Specifies the specific input signal number which shows the signal status.	No:1 to 1280 Variable B//D/LB/LI/LD can be used.
7	SOUT#(Specific output number)	Specifies the specific output signal number which shows the signal status.	No:1 to 1600 Variable B//D/LB/LI/LD can be used.
8	IGH#(Input group number)	Specifies the general input group number (1 group 4 points) signal which shows the signal status.	No:1 to 512 Variable B//D/LB/LI/LD can be used.
9	OGH#(Output group number)	Specifies the number of general output group (1 group 4 points) signal which shows the signal status.	No:1 to 512 Variable B//D/LB/LI/LD can be used.



Input signal

Input signal IN#(xx) is 1 point, IGH#(xx) is 1 group 4 points, and IG#(xx) is 1group 8 points.

IN#(8)	IN#(7)	IN#(6)	IN#(5)	IN#(4)	IN#(3)	IN#(2)	IN#(1)
IGH#(2)				IGH#(1)			
IG#(1)							

Example

(1) DIN B016 IN#(12)

The on/off status of general input signal no.12 is shown in byte type variable No.16. When the general input signal No.12 is on, the status of the general input signal is B016=1 (decimal)=00000001(binary).

DX100

2 INFORM Explanation
2.1 I/O Instructions

- (2) DIN B002 OG#(8)
The on/off status of general output signal nos. 57-64 is shown in byte type variable No.2.
In the following cases, the status of the general output signal is B002=150 (decimal)= 10010110 (binary).

OT#(64)	OT#(63)	OT#(62)	OT#(61)	OT#(60)	OT#(59)	OT#(58)	OT#(57)
OG#(8)							

ON

WAIT

Function

Waits until the status of the external signal or byte type variable is the same as the specified status.

Construction

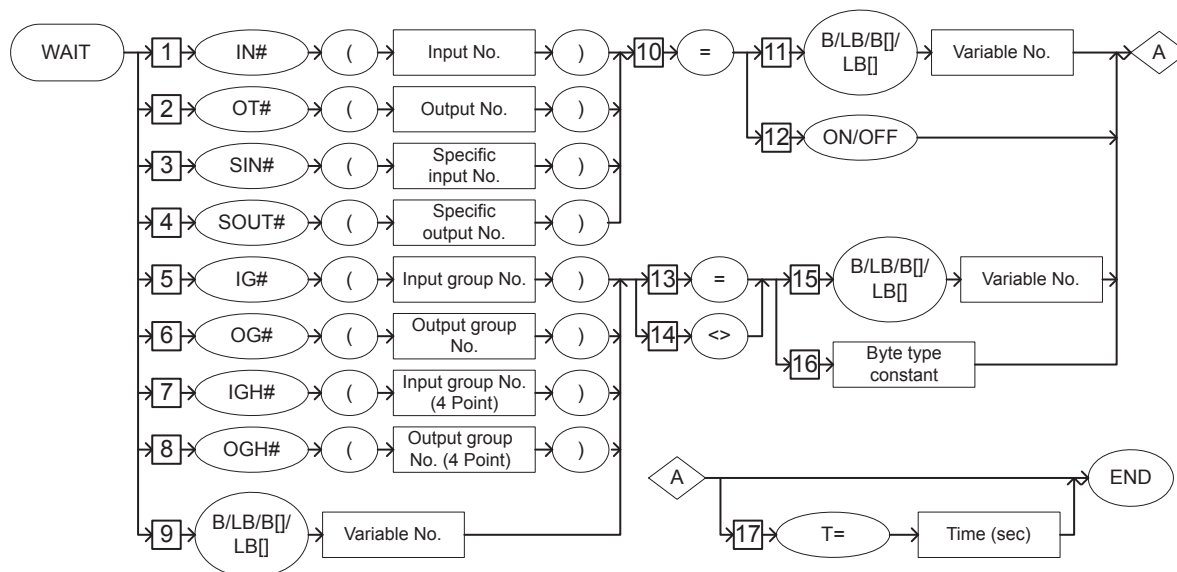

Explanation

1. IN#(Input number) / OT#(Output number) / SIN#(Specific input number) / SOUT#(Specific output number) / IG#(Input group number) / OG#(Output group number) / IGH#(Input group number) / OGH#(Output group number) / B Variable Number / LB Variable Number / B [Array Number] / LB [Array Number]

DX100

2 INFORM Explanation

2.1 I/O Instructions

Choose one of the tags from the following table.

No	Tag	Explanation	Note
1	IN# (Input number)	Specifies the number of the general input signal for the waiting condition.	No:1 to 2048 Variable B//D/LB/LI/LD can be used.
2	OT# (Output number)	Specifies the number of the general output signal for the waiting condition.	No:1 to 2048 Variable B//D/LB/LI/LD can be used.
3	SIN# (Specific input number)	Specifies the number of the specific input signal for the waiting condition.	No:1 to 1280 Variable B//D/LB/LI/LD can be used.
4	SOUT# (Specific output number)	Specifies the number of the specific output signal for the waiting condition.	No:1 to 1600 Variable B//D/LB/LI/LD can be used.
5	IG#(Input group number)	Specifies the number of general input group (1 group 8 points) signal for the waiting condition.	No:1 to 256 Variable B//D/LB/LI/LD can be used.
6	OG#(Output group number)	Specifies the number of general output group (1 group 8 points) signal for the waiting condition.	No:1 to 256 Variable B//D/LB/LI/LD can be used.
7	IGH#(Input group number)	Specifies the number of general input group (1 group 4 points) signal for the waiting condition.	No:1 to 512 Variable B//D/LB/LI/LD can be used.
8	OGH#(Output group number)	Specifies the number of general output group (1 group 4 points) signal for the waiting condition.	No:1 to 512 Variable B//D/LB/LI/LD can be used.
9	B Variable number/ LB Variable number/ B [Array number]/ LB [Array number]	Specifies the byte type variable for the waiting condition.	

2. =

When an IN# (input number), OT# (output number), SIN# (specific input number), or SOUT# (specific output number) is selected from the table in part 1 of this Explanation, add the following tag.

No	Tag	Explanation	Note
10	=	It is equal.	

3. B Variable number /LB Variable number / B [Array number] / LB [Array number] / ON / OFF

When an IN# (input number), OT#(output number), SIN# (specific input number), or SOUT# (specific output number) is selected from the table in part 1 of this Explanation, choose one of the tags from the following table.

No	Tag	Explanation	Note
11	B Variable number/ LB Variable number/ B [Array number]/ LB [Array number]	Specifies byte type variable which becomes a waiting condition.	Least significant bit: 0:OFF 1:ON
12	ON/OFF	Specifies on/off of the waiting condition.	

4. =/<>

When an IG# (input group number), OG# (output group number), IGH# (input group number), OGH# (output group number), B variable number, LB variable number, B [array number], or LB [array number] is selected from the table in part 1 of this Explanation, choose one of the tags from the following table.

No	Tag	Explanation	Note
13	=	It is equal.	
14	<>	It is not equal.	

5. B Variable number / LB Variable number / B [Array number] / LB [Array number] / Byte type constant

When an IG# (input group number), OG# (output group number), IGH# (input group number), OGH# (output group number), B variable number, LB variable number, B [array number], or LB [array number] is selected from the table in part 1 of this Explanation, choose one of the tags from the following table.

No	Tag	Explanation	Note
15	B Variable number/ LB Variable number/ B [Array number]/ LB [Array number]	Specifies byte type variable which becomes a waiting condition.	
16	Byte type constant	The waiting condition is specified by byte type constant.	

6. T=time

The following tag can be added or omitted.

No	Tag	Explanation	Note
17	T=time	Specify the waiting time. When the time specified here ends, if the status and the condition are not the same, the next instruction is executed.	Time: 0 to 655.35 seconds It is possible to specify at time by the I/LI/I/LI variable (Units: 0.01 seconds).

Example

(1) WAIT IN#(12)=ON
Waits until general input signal no.12 is turned on.

(2) SET B000 5
SET B002 16
WAIT SIN#(B000)=B002 T=3.0

B002=16 (Decimal)=00010000 (Binary)

Waits until specific input signal no.5 is turned off.

However, after three seconds, even if the signal is not turned off, the next instruction is executed.

(3) WAIT IGH#(2)<>5
5 (Decimal)=0101 (Binary)

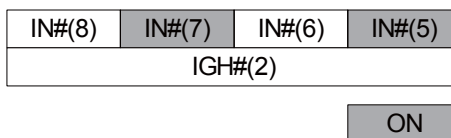

Waits until general input signal nos.5 and 7 are turned off and general input signal nos. 6 and 8 are turned on.

(4) Example of press machine handling.

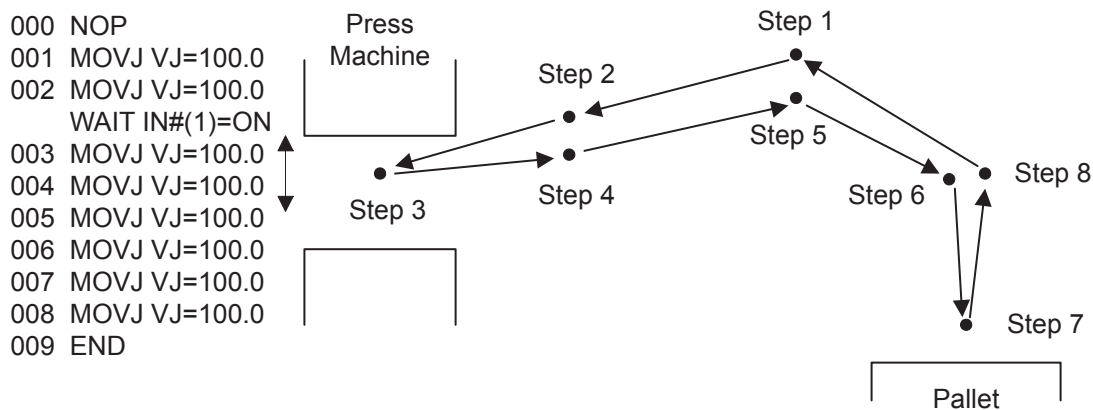

The robot cannot be moved to step 3 while the press is closed.

Open/close of the press machine (Open: ON, Shut: OFF) is allocated to general input signal No.1.

The robot waits until general input signal No.1 turns on at step 2.

PULSE

SUBSET	STANDARD	EXPANDED
Available	Available	Available

Function

The pulse signal is output to the general output signal only for the specified time.

The PULSE instruction, without waiting for completion of the instruction, executes the next one.

Construction

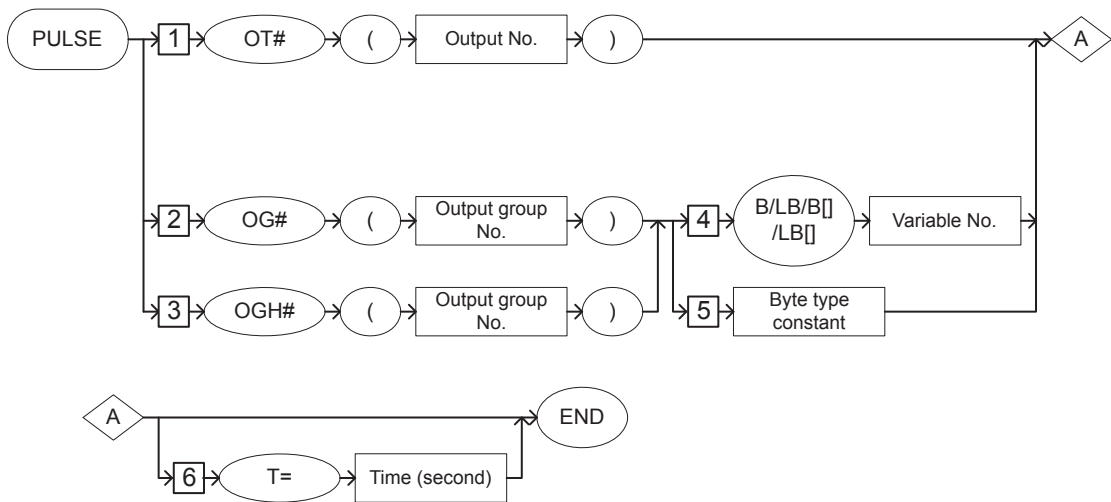

Explanation

- OT# (output number) / OG# (output group number) / OGH# (output group number)

Choose one of the tags from the following table..

No	Tag	Explanation	Note
1	OT# (Output No.)	Specifies the number of the signal to which the pulse signal is output.	No.: 1 to 2048 Variable B/I/D/LB/LI/ LD can be used.
2	OG# (Output group No.)	Specifies the group number of the signal (1 group 8 points) to which the pulse signal is output.	No.: 1 to 256 Variable B/I/D/LB/LI/ LD can be used.
3	OGH# (Output group No.)	Specifies the group number of the signal (1 group 4 points) to which the pulse signal is output.	No.: 1 to 512 Variable B/I/D/LB/LI/ LD can be used.

DX100

2 INFORM Explanation
2.1 I/O Instructions

2. B Variable number / LB Variable number / B [Array number] / LB [Array number] / Byte type constant

When OG# (output group number) or OGH# (output group number) in the above table is selected, choose one of the tags from the following table.

No.	Tag	Explanation	Note
4	B Variable number/ LB Variable number/ B [Array Number] / LB [Array Number]	Specifies the number of the corresponding pulse output signal when the contents of the specified byte type variable is expressed in bits.	Bit: 0: OFF 1: ON
5	Byte type constant	Specifies the number of the corresponding pulse output signal when the specified byte type constant is expressed in bits.	

3. T=Time

The following tag can be added or omitted.

No.	Tag	Explanation	Note
6	T=Time	Specifies the time during which the pulse signal is output. The pulse signal is output during the specified time T.	Units: seconds Variable I/LI/I[]/LI[] can be used. (Units: 0.01 seconds) When the time is not specified, the pulse signal is output during 0.30 seconds.

Example

- (1) PULSE OT#(128)
The pulse signal is output for 0.30 seconds to general output signal No.128.

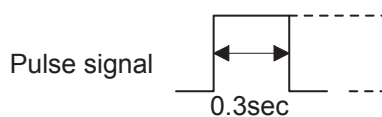

- (2) SET B000 5
PULSE OT#(B000) T=1.0

The pulse signal is output for 1.0 seconds to general output signal No.5.

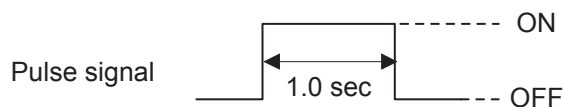

- (3) SET B000 24
 PULSE OG#(3) B000

B000=24 (Decimal)=00011000 (Binary)

OT#(24)	OT#(23)	OT#(22)	OT#(21)	OT#(20)	OT#(19)	OT#(18)	OT#(17)
OG#(3)							

ON

The pulse signal is output for 0.30 seconds to the general output signal No.'s 20 and 21.

AOUT

SUBSET	STANDARD	EXPANDED
Not available	Available	Available

Function

Outputs the set voltage value to the general-purpose analog output port.

Construction

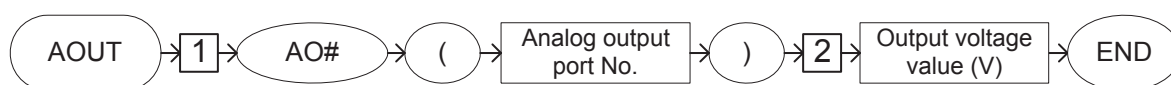

Explanation

1. AO# (Analog output port number)

Add the following tag.

No	Tag	Explanation	Note
1	AO# (Analog output port number)	Specifies the number of the analog output port to which the set voltage value is output.	No.: 1 to 40 Variable B/I/D/LB/LI/LD can be used.

2. Output voltage value

Add the following tag.

No.	Tag	Explanation	Note
2	Output voltage value	Specifies the output voltage value.	Voltage value: -14.00 to +14.00 Variable I/LI/I[]/LI[] can be used. (Units: 0.01 V)

Example

- (1) SET I000 1270
AOUT AO#(1) I000
The voltage of 12.7 V is output to the analog output port No. 1.

ARATION

SUBSET	STANDARD	EXPANDED
Not available	Available	Available

Function

Starts the analog output corresponding to the speed.

ARATION is valid during linear interpolation, circular interpolation, and spline interpolation. ARTION is carried out during playback or FWD operation, but not while operating an axis.

Construction

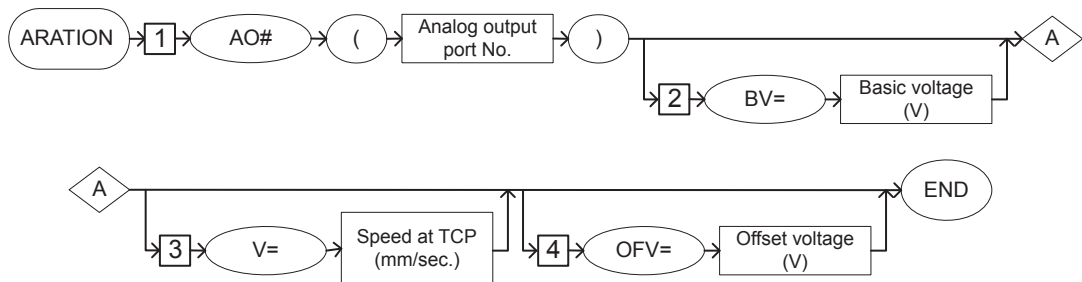

Explanation

1. AO# (Analog output port number)

Add the following tag.

No.	Tag	Explanation	Note
1	AO# (Analog output port number)	Specifies the number of the analog output port that outputs the voltage corresponding to the speed.	No.: 1 to 40 Variable B/I/D/LB/LI/LD can be used.

2. BV=Basic voltage

The following tag can be added or omitted.

No.	Tag	Explanation	Note
2	BV=Basic voltage	Specifies the voltage to be output when running at the speed set in part 3 of this Explanation.	Voltage value: -14.00 to +14.00 V Variable I/LI/I[]/LI[] can be used. (Units: 0.01 V)

DX100

2 INFORM Explanation
2.1 I/O Instructions

3. V=Basic speed

The following tag can be added or omitted.

No.	Tag	Explanation	Note
3	V=Basic speed	Specifies the speed at which the set voltage value is output.	Speed: 0.1 to 1500.0 mm/s. Variable B/I/D/LB/LI/LD can be used. (Units: 0.1 mm/s.)

4. OFV=Offset voltage

The following tag can be added or omitted.

No.	Tag	Explanation	Note
4	OFV=Offset voltage	Specifies the analog voltage to be output at the motion speed "0".	Voltage value: -14.00 to +14.00 V Variable I/LI/I[]/LI[] can be used. (Units: 0.01 V)



Analog output function corresponding to the speed

To regulate the thickness of the sealing or paint, etc. when sealing and painting, the amount of discharged material should be adjusted according to the motion speed of the manipulator.

The analog output function corresponding to the speed automatically changes the analog output value according to the manipulator's motion speed.

ARATION and ARTIOF instructions are used to carry out this function.

On the base of the set value for the ARATION instruction, the output characteristic, which decides the relation between the motion speed and the analog voltage, is calculated. The analog output corresponding to speed is output according to this output characteristic.

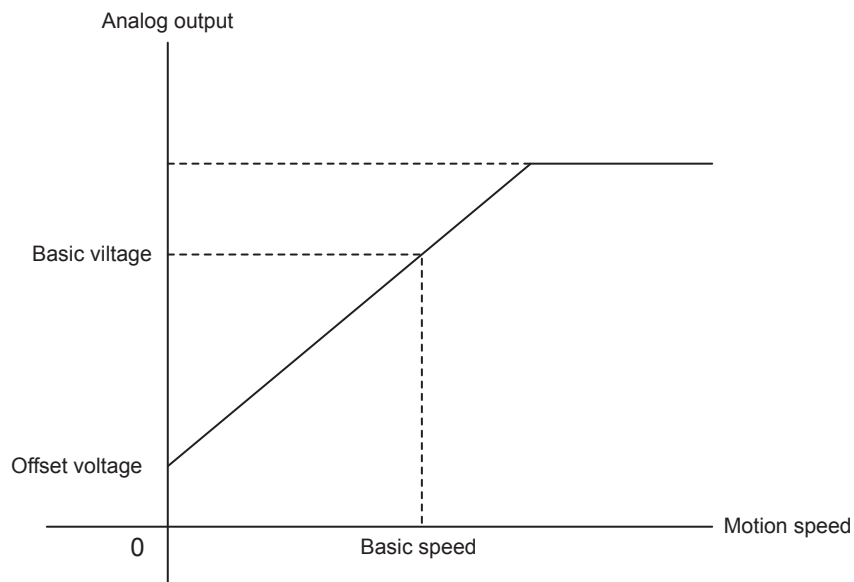

Example

(1)	
MOVJ VJ=50.00	Output voltage (V)
ARATION AO#(1) BV=7.00 V=150.0 OFV=-10.0	7.00
MOVL V=50.0	4.33
MOVC V=100.0	1.33
MOVC V=100.0	1.33
MOVC V=100.0	1.33
MOVL V=200.0	12.67

When the basic voltage is 7.00 V at a motion speed of 150.0 mm/sec for the analog output port number 1, an offset voltage of -10.0 V is output.

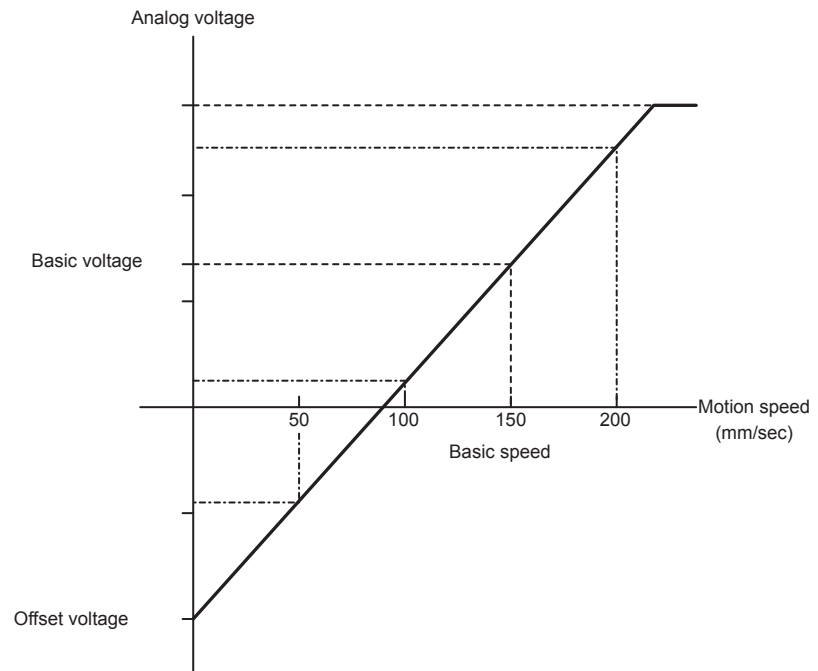

ARATIOF

SUBSET	STANDARD	EXPANDED
Not available	Available	Available

Function

Cancels the analog output corresponding to the speed.

Construction

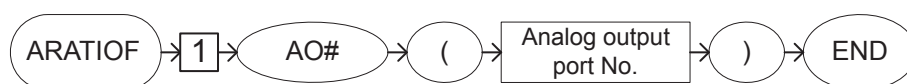

Explanation

1. AO# (Analog output port number)

Add the following tag.

No.	Tag	Explanation	Note
1	AO# (Analog output port number)	Specifies the number of the general-purpose analog output port for which the analog output corresponding to speed is to be cancelled.	No.: 1 to 40 Variable B/I/D/LB/LI/LD can be used.

Example

- (1) ARATIOF AO#(1)
The analog output corresponding to the speed at the analog output port number 1 is cancelled.

ANTOUT

The ANTOUT instruction can be used only with parameter S4C008.

SUBSET	STANDARD	EXPANDED	Parameter
Not available	Available	Available	S2C646

Function

Carries out the anticipation output function to adjust the timing of the signal output.



Anticipation output function

The anticipation output function is a signal output timing adjustment function to advance or delay the ON/OFF timing of four general-purpose outputs and two general-purpose output groups. The signal can be output before or after the manipulator reaches the step.

This function corrects work timing errors due to delays in the motions of a peripheral device and/or the manipulator.

Setting the time to a negative value (-) advances the signal output.

This can be used to correct work timing errors due to delays in the motions of a peripheral device.

Setting the time to a positive value (+) delays the signal output.

This can be used to correct work timing errors due to delays in the motions of the manipulator.

<Advanced signal output>

The signal is output before the manipulator reaches the step.

Step	Instructions
n-1	MOVL
n	MOVL NWAIT ANTOUT AT#(1) ON
n+1	MOVL

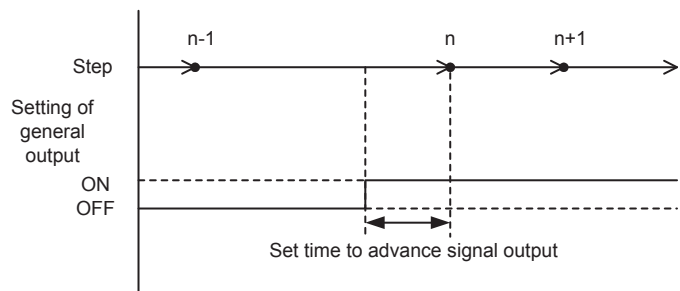

<Delayed signal output>

The signal is output after the manipulator reaches the step.

Step	Instructions
n-1	MOVL
n	MOVL NWAIT ANTOUT AT#(2) ON
n+1	MOVL

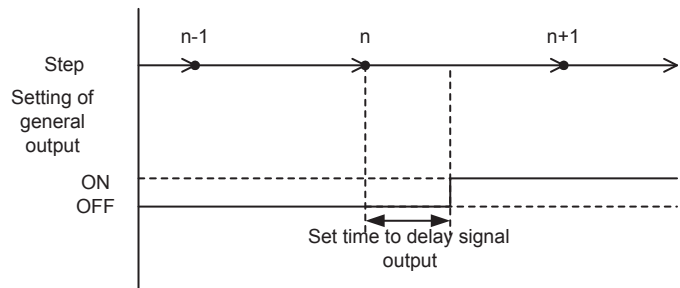

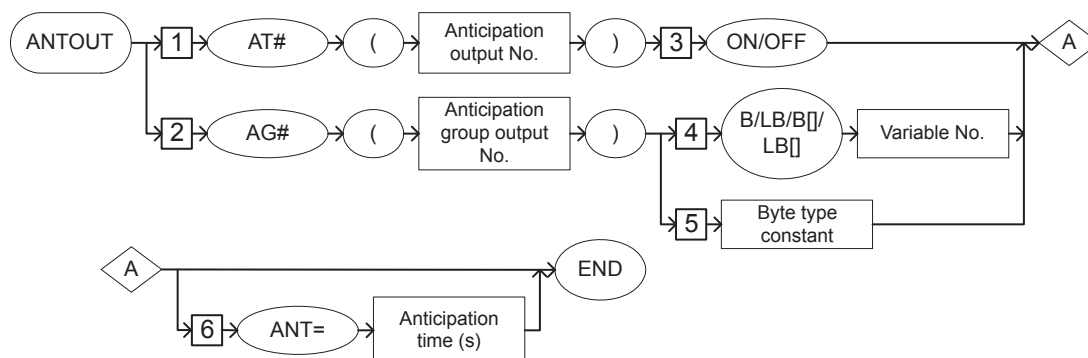
Construction**Explanation**

1. AT# (Anticipation output number) / AG# (Anticipation group output number)

Choose one of the tags from the following table.

No.	Tag	Explanation	Note
1	AT# (Anticipation output number)	Specifies the number of the signal whose timing is adjusted.	No.: 1 to 32 Variable B/I/D/LB/LI/LD can be used.
2	AG# (Anticipation group output number)	Specifies the group number of the signal whose timing is adjusted.	No.: 1 or 16 Variable B/I/D/LB/LI/LD can be used.



Settings for the anticipation output signal

Set the number of the output signal for the anticipation output in the ANTICIPATION OUTPUT display.

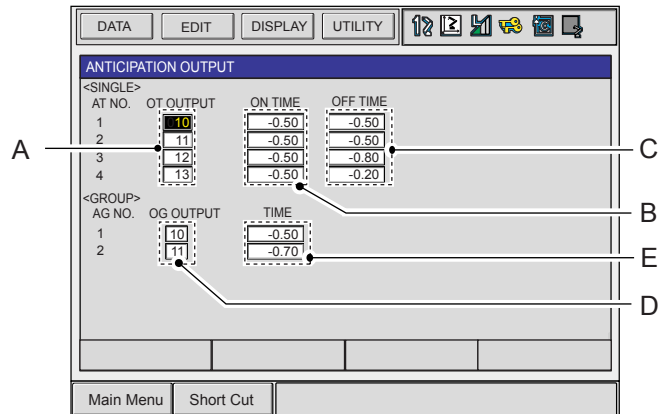

- A. OT OUTPUT (Setting range: 1 to 192)
Allocate the number of the general-purpose output whose signal timing is to be adjusted to AT NO. 1 to 4.
- B. ON TIME (Setting range: -327.68 to 327.67 seconds)
Set the delay/advance time for turning ON the signal.
- C. OFF TIME (Setting range: -327.68 to 327.67 seconds)
Set the delay/advance time for turning OFF the signal.
- D. OG OUTPUT (Setting range: 1 to 24)
Allocate the group number of the general-purpose output whose signal timing is to be adjusted to AG NO. 1 and 2.
- E. TIME (Setting range: -327.68 to 327.67 seconds)
Set the delay/advance time for carrying out the group output.

2. ON/OFF

When an AT# (anticipation output number) is selected from the table in part 1 of this Explanation, add the following tag.

No.	Tag	Explanation	Note
3	ON/OFF	Specifies the ON/OFF status of the signal whose output timing is adjusted.	

DX100

2 INFORM Explanation
2.1 I/O Instructions

3. B Variable number / LB Variable number / B [Array number] / LB [Array number] / Byte type constant

When an AG# (anticipation group output number) is selected from the table in part 1 of this Explanation, choose one of the tags from the following table.

No.	Tag	Explanation	Note
4	B Variable number/ LB Variable number/ B [Array number]/ LB [Array number]	Specifies the ON/OFF status of the output signal corresponding to each bit when the contents of the specified byte type variable is expressed in bits.	Bit: 0: OFF 1: ON
5	Byte type constant	Specifies the ON/OFF status of the output signal corresponding to each bit when the contents of the specified byte type variable is expressed in bits.	

4. ANT=Anticipation time

The following tag can be added or omitted.

No.	Tag	Explanation	Note
6	ANT=Anticipation time	Specifies the delay/advance time for the output signal timing.	Units: seconds Variable I/LI/I[]/LI[] can be used. (Units: 0.01 seconds) When the time is not specified, the time set in the signal timing adjustment file is applied.

Example

(1) <u>Step</u>	<u>Instructions</u>
n-1	MOVL V=100
n	MOVL V=100 NWAIT ANTOUT AT#(1) ON
n+1	MOVL V=100

Turns ON the general-purpose signal number 10 0.5 seconds before the manipulator reaches the step.(Advanced signal output)

ANTICIPATION OUTPUT			
<SINGLE>			
AT NO.	OT OUTPUT	ON TIME	OFF TIME
1	10	0.00	-0.50
2	11	0.00	-0.50
3	---	0.00	0.00
4	---	0.00	0.00
<GROUP>			
AG NO.	OG OUTPUT	TIME	
1	---	0.00	
2	---	0.00	

2.2 Control Instruction

JUMP

SUBSET	STANDARD	EXPANDED
Available	Available	Available

Function

Jumps to specified label or job.

Construction

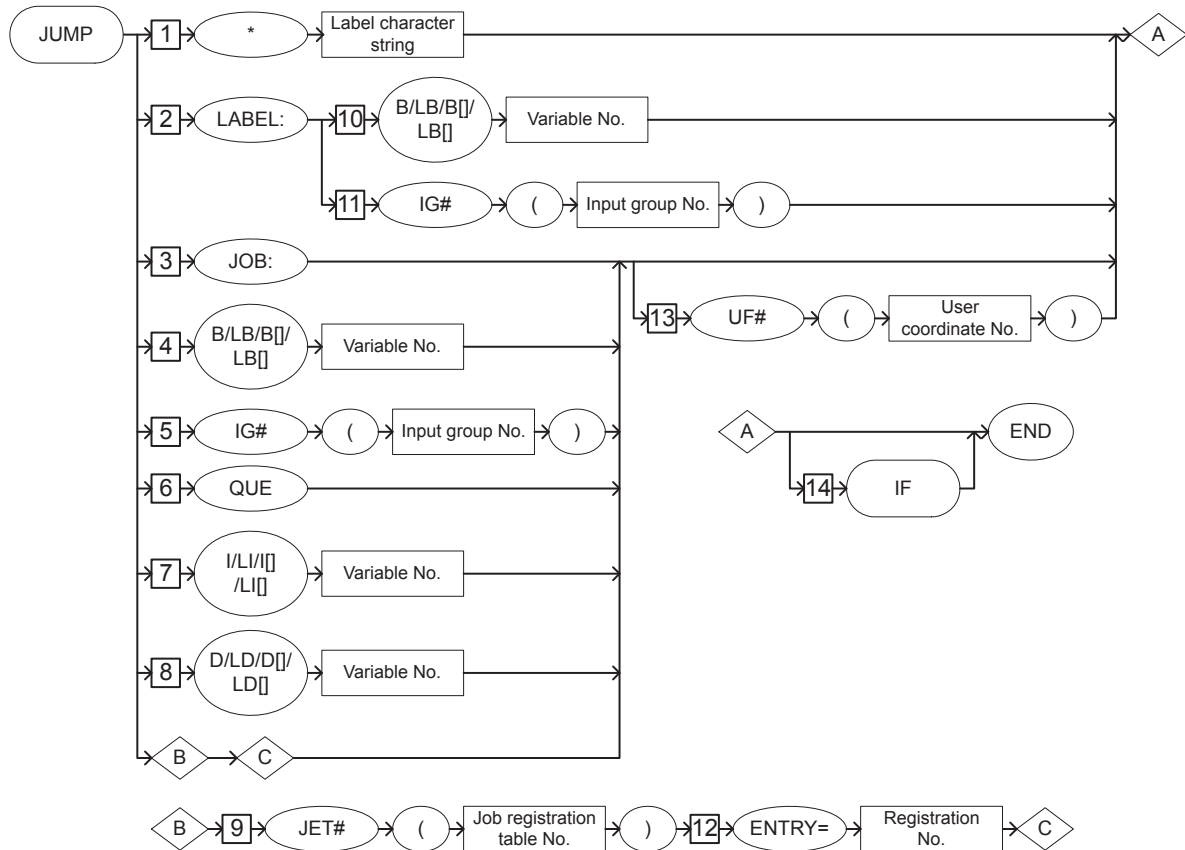

2.2 Control Instruction

Explanation

1. *Label character string /LABEL:/JOB:/B Variable number /LB Variable number /B [Array number] /LB [Array number] /IG# (Input group number) / QUE/I Variable number/LI Variable number/I [Array number]/LI [Array number]/D Variable number/LD Variable number/ D [Array number]/LD [Array number]/ JET# (Job registration table number)

Choose one of the tags from the following table.

No	Tag	Explanation	Note
1	*Label strings	Specifies the label string.	String: eight characters
2	LABEL:	The numerical value specified by byte type variable or input group number is considered a label.	
3	JOB:	Specifies the job.	
4	B Variable number/ LB Variable number/ B [Array number]/ LB [Array number]	The numerical value specified by byte type variable is considered to be a job.	
5	IG#(Input group number)	The numerical value specified by the input group number is considered to be a job.	No:1 to 256 Variable B/I/D/LB/LI/LD can be used.
6	QUE	Jumps to the job stored in the queue.	Available only in the queue function (option: S2C503).
7	I Variable number/ LI Variable number/ I [Array number]/ LI [Array number]	The numerical value specified by the integer type variable is considered to be the job.	
8	D Variable number/ LD Variable number/ D [Array number]/ LD [Array number]	The numerical value specified by the double-precision type variable is considered to be the job.	
9	JET# (Job registration table number)	Specifies the job registration table number. The job of the jump destination can be registered in the job registration table.	No.: 1 to 3 Variable B/I/D/LB/LI/LD can be used. Available only with the job registration table function (option: S2C345)

2.2 Control Instruction

2. B Variable number / LB Variable number / B [Array number] / LB [Array number] / IG# (Input group number)

When a LABEL: is selected from the table in part 1 of this Explanation, choose one of the tags from the following table.

No	Tag	Explanation	Note
10	B Variable number/ LB Variable number/ B [Array number]/ LB [Array number]	Specifies the byte type variable in which the numerical value for the label is set.	
11	IG#(Input group number)	Specifies the input group number of the numerical value for the label.	No:1 to 256 B/I/D/LB/LI/LD Variable can be used.

3. ENTRY=Registration number

When a JET#(job registration table number) is selected from the table in part 1 of this Explanation, add the following tag.

No.	Tag	Explanation	Note
12	ENTRY=Registration number	Specifies the registration number of the job registered in the specified job registration table.	No.: 1 to 1024 Variable B/B[]/LB/LB[]/I/I[] can be used.

4. UF# (User coordinate number)

When JOB:, B variable number, LB variable number, B [Array number], LB [Array number], IG# (Input group number), QUE, I Variable number, LI Variable number, I [Array number], LI [Array number], D Variable number, LD Variable number, D [Array number], LD [Array number], or JET# (Job registration table number) is selected from the table in part 1 of this Explanation, the following tag can be added.

No	Tag	Explanation	Note
13	UF# (User coordinate number)	Specifies the coordinates of the job.	Available only in the relative job function.

5. IF

The following tag can be added or omitted.

No	Tag	Explanation	Note
14	IF	Specifies the IF instruction.	Refer to <i>chapter 2.6 "Instruction Which Adheres to an Instruction"</i> at page 2-219.

2.2 Control Instruction

Example

- (1) JUMP *1
Jumps to *1.

- (2) JUMP JOB:TEST1 UF#(2)
Jumps to the job named TEST1. TEST1 works in user coordinate system No.2.

- (3) SET B000 1
JUMP B000 IF IN#(14)=ON
If input signal no.14 is on, it jumps to job "1".

CALL

SUBSET	STANDARD	EXPANDED
Available	Available	Available

Function

Calls the specified job.

Construction

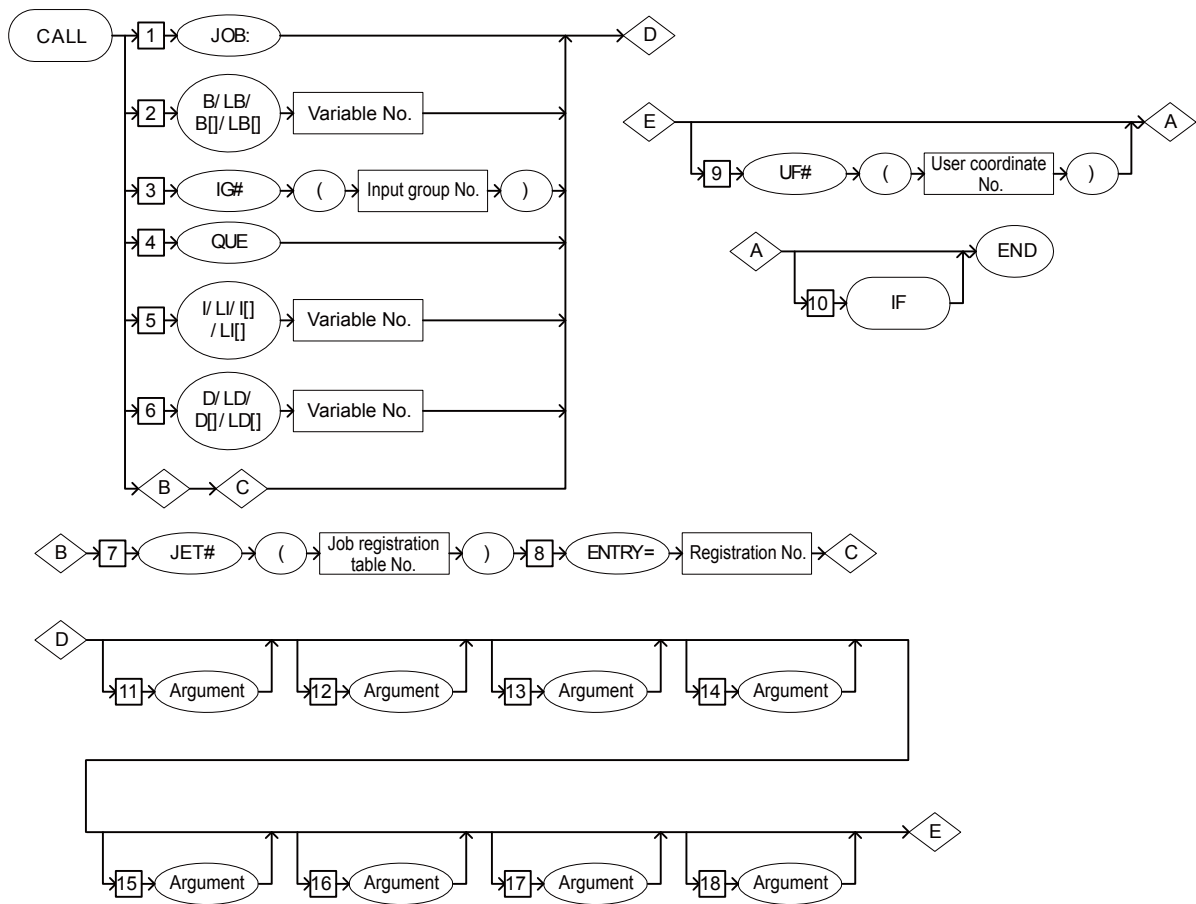

2.2 Control Instruction

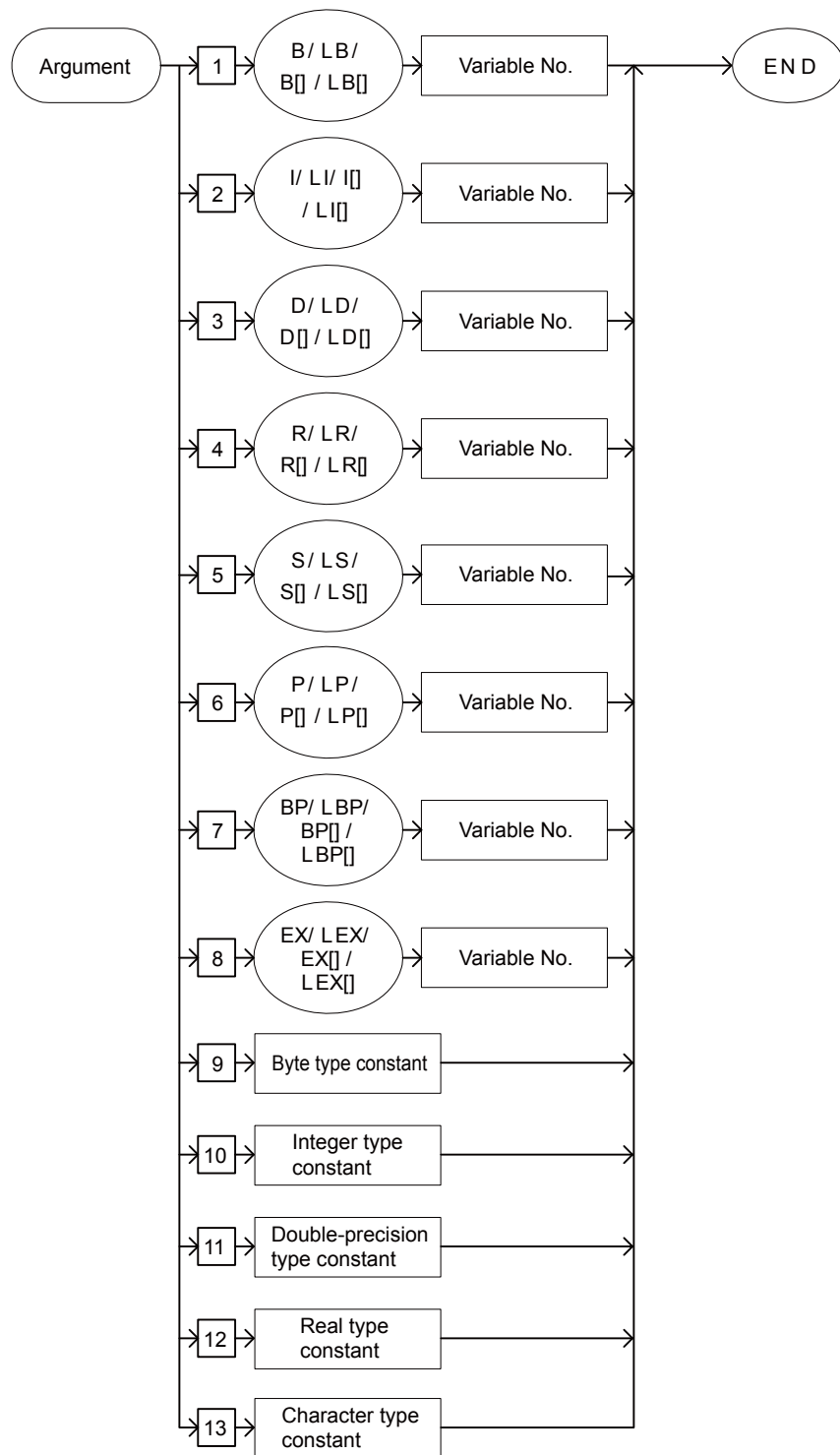

2.2 Control Instruction

Explanation

1. JOB: / B Variable number / LB Variable number / B [Array number] / LB [Array number] / IG#(Input group number) / QUE/I Variable number/LI Variable number/I [Array number]/LI [Array number]/D Variable number/LD Variable number/ D [Array number]/LD [Array number]/ JET# (Job registration table number)

Choose one of the tags from the following table.

No	Tag	Explanation	Note
1	JOB:	Specifies a job to be called.	
2	B Variable number/ LB Variable number/ B [Array number]/ LB [Array number]	The numerical value specified by the byte type variable is considered as the job to be called.	
3	IG# (Input group number)	The numerical value specified by the input group number is considered as the job to be called.	No.: 1 to 256 Variable B//D/LB/LI/LD can be used.
4	QUE	The job stored in the queue is called.	Available only in the queue function (option: S2C503).
5	I Variable number/ LI Variable number/ I [Array number]/ LI [Array number]	The numerical value specified by the integer type variable is considered as the job to be called.	
6	D Variable number/ LD Variable number/ D [Array number]/ LD [Array number]	The numerical value specified by the double-precision type variable is considered as the job to be called.	
7	JET# (Job registration table number)	Specifies the table number of the job registration. The job to be called can be registered in the job registration table.	No.: 1 to 3 Variable B//D/LB/LI/LD can be used. Available only in the job registration table function (option: S2C345)

2. ENTRY=Registration number

When a JET#(job registration table number) is selected from the table in part 1 of this Explanation, add the following tag.

No.	Tag	Explanation	Note
8	ENTRY=Registration number	Specifies the registration number of the job registered in the specified job registration table.	No.: 1 to 1024 Variable B/B[]/LB/LB[]/I/I[]/ LI/LI[] can be used.

DX100

2.2 Control Instruction

3. UF# (User coordinate number)

The following tag can be added or omitted.

No	Tag	Explanation	Note
9	UF# (User coordinate number)	Specifies the user coordinate system of the job to be called.	Available only in the relative job function.

4. IF

The following tag can be added or omitted.

No	Tag	Explanation	Note
10	IF	Specifies the IF instruction.	Refer to <i>chapter 2.6 "Instruction Which Adheres to an Instruction"</i> at page 2-219.

5. Argument

The following tag can be added or omitted.

No	Tag	Explanation	Note
11 to 18	Argument (all types of variables and constants)	Eight arguments (from 11 to 18) can be passed to the job to be called. All types of variables and constants can be used as arguments.	

Example

- (1) CALL JOB:TEST1
The job named TEST1 is called.
- (2) SET B000 1
CALL B000 IF IN#(14)=ON
If input signal No.14 is on, it calls the job "1".

1. Outline (CALL Instruction with Argument)

The CALL instruction was the function with which the calling job would only call and execute the specified called job. This time, the function to pass information to the called job as arguments was newly added. Up to 8 arguments can be passed.

The RET instruction only meant the return of the execution from the called job. This time, it became possible to return one return value to the calling job. This enables the transfer of information without using the global variable to pass information. Thus, it makes the management of information easier, the number of lines of the calling job fewer, and the process simpler.

2.2 Control Instruction

(1) CALL Instruction with Argument

For example, when creating the job which only waits for incoming in order to wait for the incoming of I/Os, the input number's incoming to be waited for had to be set to the global variable, and the information had to be passed from the calling job to the called job. For example, the case when the input of specified three points are IN#(1), IN#(5), and IN#(7) is as follows:

<Calling Job>

```

NOP
SET B000 1
SET B001 5
SET B002 7
CALL JOB: WAIT_INPUT

```

:

<Called Job>

Job name: WAIT_INPUT

```

NOP
WAIT IN#(B000) ON
WAIT IN#(B001) ON
WAIT IN#(B002) ON
RET

```

This makes the calling job program long, and the global variable will be used only for this information transfer.

By using the CALL instruction with argument, the above can be described as follows:

<Calling Job>

```

NOP
CALL JOB: WAIT_INPUT (1, 5, 7)

```

:

<Called Job>

Job name: WAIT_INPUT

2.2 Control Instruction

NOP

GETARG LB000, IARG#(1)// INPUT NUMBER 1 (receiving the argument 1)

GETARG LB001, IARG#(2)// INPUT NUMBER 2 (receiving the argument 1)

GETARG LB002, IARG#(3)// INPUT NUMBER 3 (receiving the argument 1)

WAIT IN#(LB000) ON

WAIT IN#(LB001) ON

WAIT IN#(LB002) ON

RET

This makes the calling job program only one-line long. Also, the called job can be made by using only the local variable.

(2) RET Instruction with Return Value

For example, to create the job which adds any two register values, the register number had to be passed from the calling job, and in the called job, the calculation result had to be entered in any of the global variable, then the calling job had to refer to that. This can be described as follows:

<Calling Job>

NOP

SET B000 1

SET B001 2

CALL JOB: ADD_REG

GET I0100 I099 ; Returns the calculation result to I099

<Called Job>

Job name: ADD_REG

NOP

GETREG I000 MREG#(B000)

GETREG I099 MREG#(B001)

ADD I099 I000

RET

By using the CALL instruction with argument and the RET instruction with return value, the above can be described as follows:

<Calling Job>

NOP

CALL JOB: ADD_REG (1, 2)

2.2 Control Instruction

GETS I001 \$RV ; Receives the addition result as the return value at \$RV

<Called Job>

Job name: ADD_REG

NOP

GETARG LB000 IARG#(1)// Register 1

GETARG LB001 IARG#(2)// Register 2

GETREG LI000 MREG#(LB000)

GETREG LI001 MREG#(LB001)

ADD LI001 I000

RET LI001 ; Returns the addition result as the return value

Thus, the global variable to receive and pass the answer is no longer necessary.

1. Operating Procedure

(1) Addition of Argument to CALL Instruction

1) Creating a Called Job

As an example, the job which resets 8 I/Os specified by arguments is created as follows:

1. Create a job.

As the example below, the job "MULTI_OUTPUT_RESET" is created.

2. Register local variables.

Arguments will be received by local variables. Thus, at least, the local variables to receive arguments must be defined. In the example, 8 byte-type variables are defined.

Open "JOB HEADER" and make the setting of <LOCAL VAR NUM>.

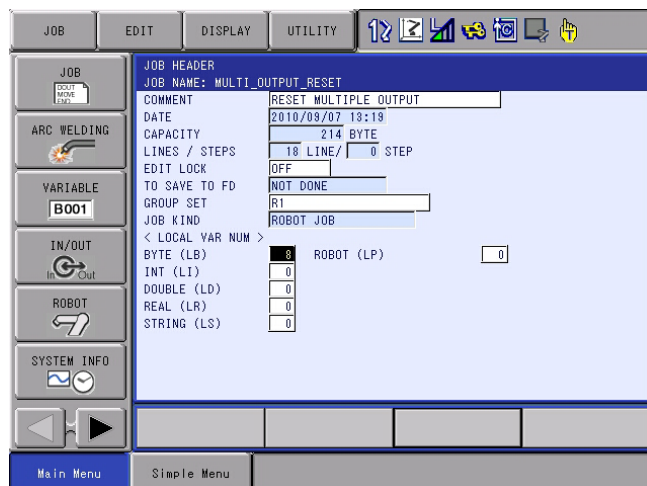

2.2 Control Instruction

3. Define arguments.

As shown below, select the pull-down menu {DISPLAY}, then {ARGUMENT INFO}.

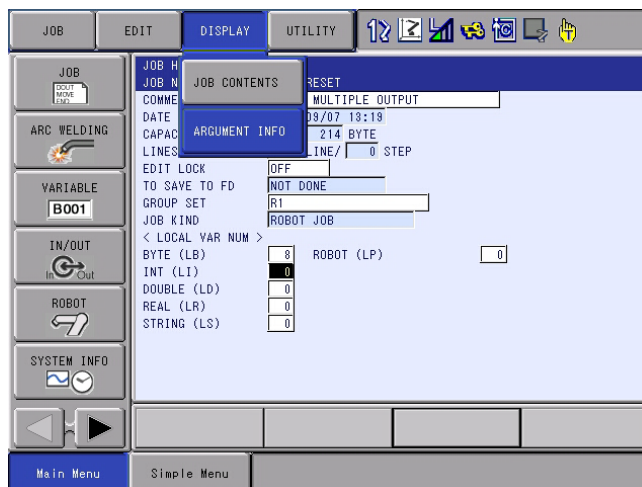

The following display appears. Then, make the setting of arguments. Set "ARG. 1 to 8" on the left to "USE", set "OUTPUT1 to 8" as "COMMENT", then select "BYTE" as "TYPE". Select {EXECUTE} to complete the registration of arguments.

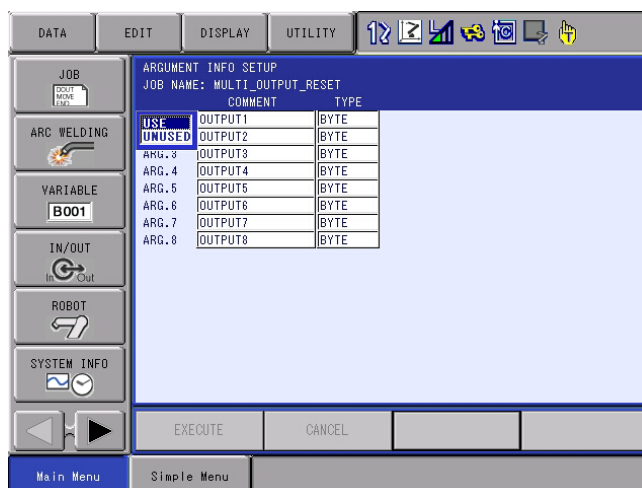

2.2 Control Instruction

4. Describe the job content.

(1) Describe lines to receive arguments.

Press [INFORM LIST], and select {CONTROL}, then “GETARG” to register instructions to receive arguments. (To register the GETARG instruction, select {Main Menu}, {SETUP}, then {TEACHING COND.}, and set “LANGUAGE LEVEL” to “EXPANDED”.) In this case, the above-mentioned COMMENT will be automatically displayed as the comments on the line of GETARG instructions as shown below. Note that arguments must be received by the local variable.

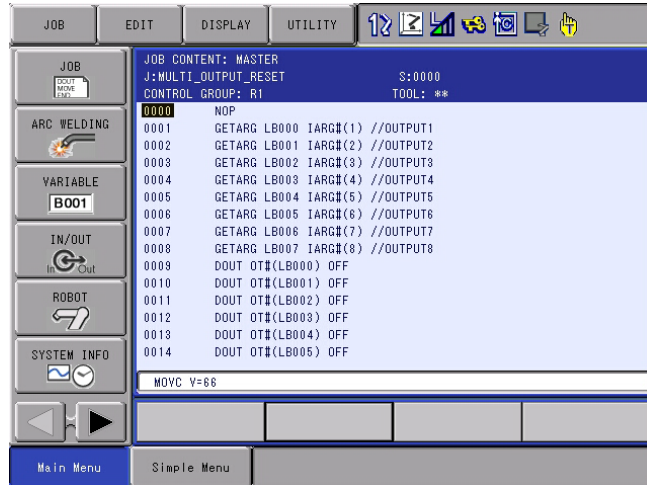

(2) The job content is as follows:

```

NOP
GETARG LB000 IARG#(1) //OUTPUT1
GETARG LB000 IARG#(2) //OUTPUT2
GETARG LB000 IARG#(3) //OUTPUT3
GETARG LB000 IARG#(4) //OUTPUT4
GETARG LB000 IARG#(5) //OUTPUT5
GETARG LB000 IARG#(6) //OUTPUT6
GETARG LB000 IARG#(7) //OUTPUT7
GETARG LB000 IARG#(8) //OUTPUT8
DOUT OT#(LB000) OFF
DOUT OT#(LB001) OFF
DOUT OT#(LB002) OFF
DOUT OT#(LB003) OFF
DOUT OT#(LB004) OFF
DOUT OT#(LB005) OFF
DOUT OT#(LB006) OFF
DOUT OT#(LB007) OFF
RET

```

2.2 Control Instruction

(3) Describe the calling job.

As shown below, call "MULTI_OUTPUT_RESET" in the job.

In this case, if the called job has 8 arguments, 8 arguments must be listed here. If the numbers are not the same, "Alarm 4608: WRONG EXECUTION OF GETARG INST" occurs at execution.

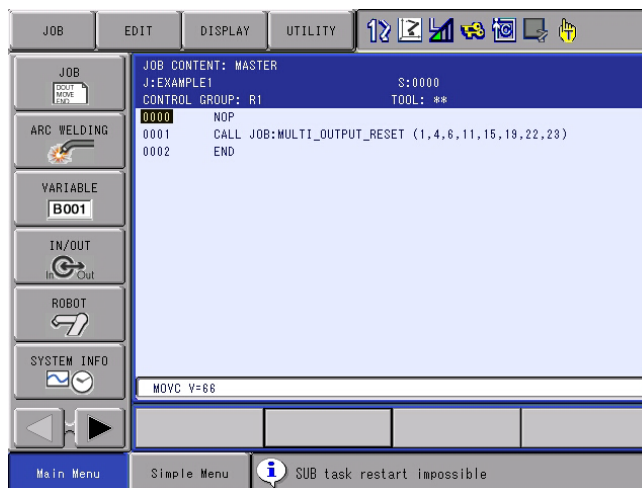

(2) RET Instruction with Return Value

1) Creating a Called Job

As an example, the job which returns 2 specified register values as the return value is created as follows:

1. Create a job.

As the example below, the job "ADD_REG" is created.

2. Register local variables.

Register 2 byte-type variables and 3 integer-type variables.

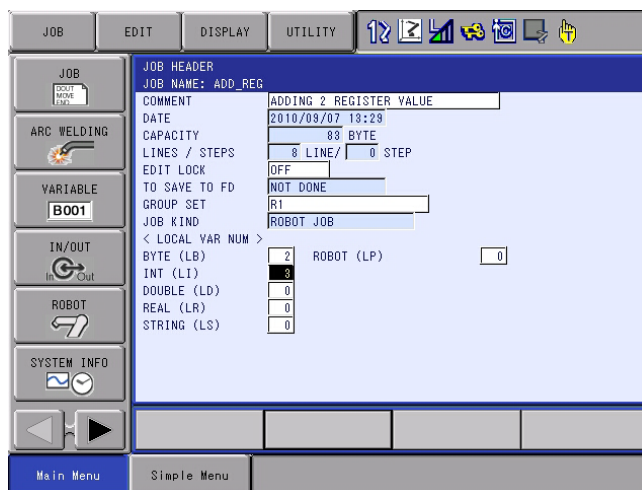

2.2 Control Instruction

3. Define arguments.
As shown below, define 2 arguments.

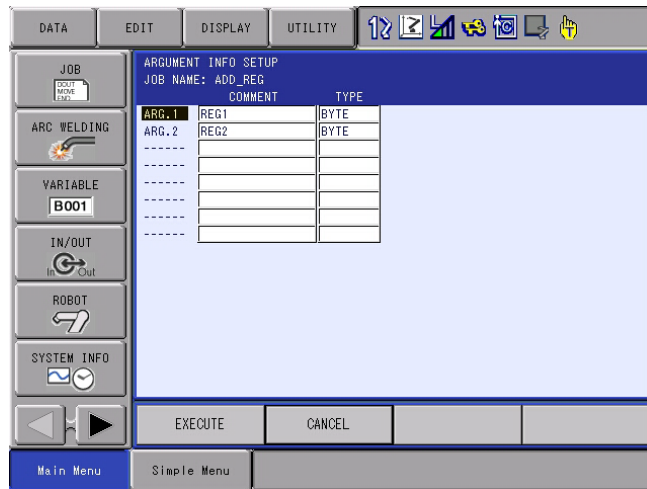

4. Describe the job content.
Describe the job content as shown below. LI000 is newly added as the return value at the RET instruction. Thus, the addition result will be returned as the return value.

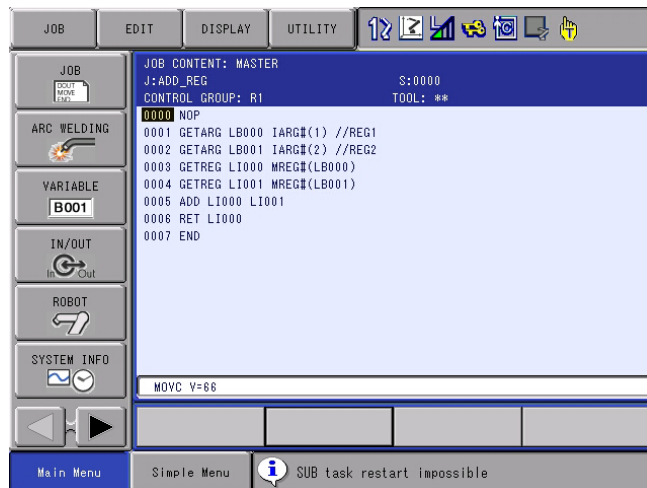

2.2 Control Instruction

(1) Describe the calling job.

As shown below, describe the calling job. The register numbers to specify are the registers 0 and 1 as "CALL JOB: ADD_REG (0, 1)" shows.

The return value is received at GETS I000 \$RV. Thus, the addition result will be returned to I000.

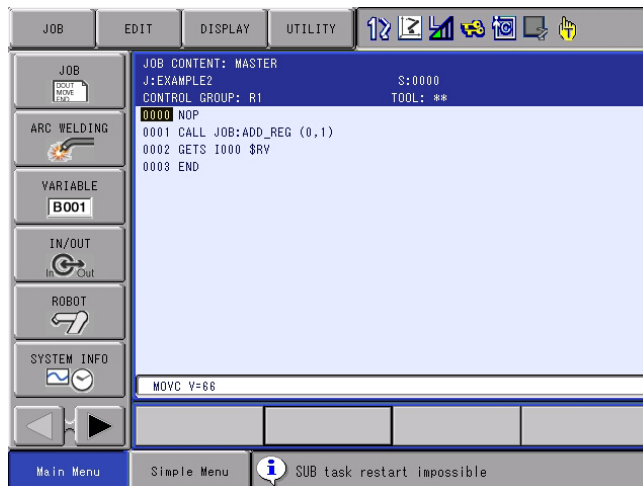

GETARG

SUBSET	STANDARD	EXPANDED
Not available	Not available	Available

Function

This is the instruction to receive arguments for the CALL instruction and macro instruction. When the instruction is executed, the argument data added to the CALL instruction or macro instruction is retrieved, then stored in the local variable specified to be used in the CALL job or macro job.

Construction

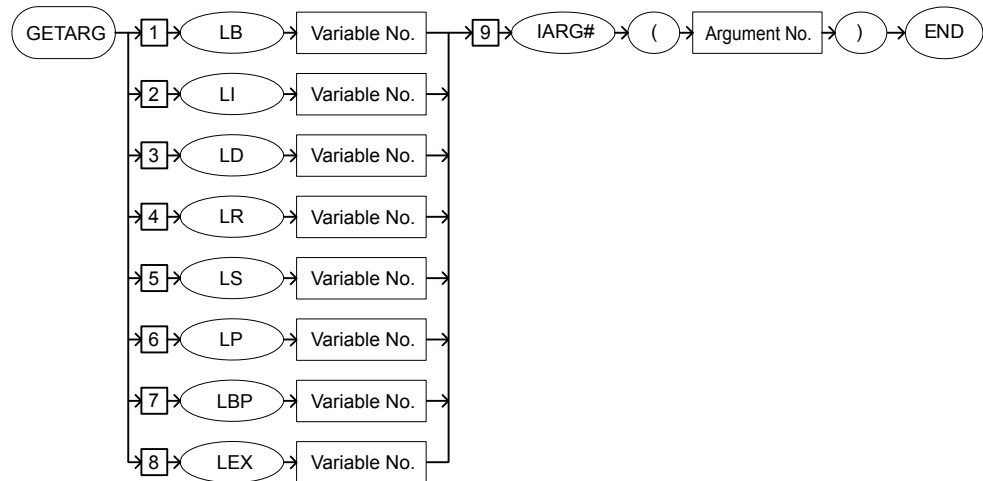

2.2 Control Instruction

Explanation

1. LB, LI, LD, LR, LS, LP, LBP, LEX

Select one of the tags from the following table.

No	Tag	Explanation	Note
1	LB Variable number LB [Array number]	Specifies the local byte type variable which stores the argument.	
2	LI Variable number LI [Array number]	Specifies the local integer type variable which stores the argument.	
3	LD Variable number LD [Array number]	Specifies the local double precision type variable which stores the argument.	
4	LR Variable number LR [Array number]	Specifies the local real type variable which stores the argument.	
5	LS Variable number LS [Array number]	Specifies the local character type variable which stores the argument.	
6	LP Variable number LP [Array number]	Specifies the local robot axis position type variable which stores the argument.	
7	LBP Variable number LBP [Array number]	Specifies the local base axis position type variable which stores the argument.	
8	LEX Variable number LEX [Array number]	Specifies the local station axis position type variable which stores the argument.	

2. IARG# (Argument No.)

Make sure to specify this.

No.	Tag	Explanation	Note
9	IARG# (Argument No.)	Specifies the argument number to be stored in the local variable.	

Example

(1) An example is shown below.

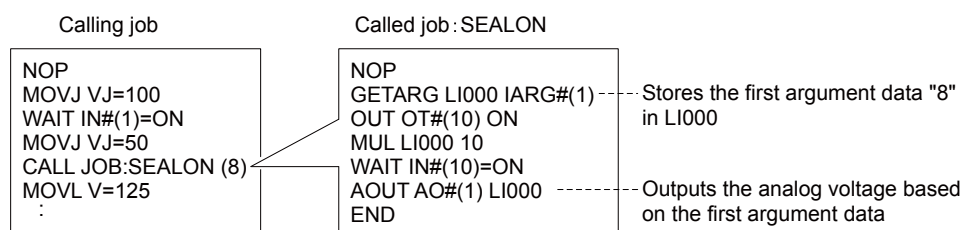

TIMER

SUBSET	STANDARD	EXPANDED
Available	Available	Available

Function

Stops for the specified time.

Construction

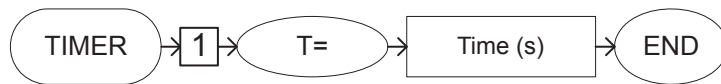

Explanation

1. T=timer

Add the following tag.

No	Tag	Explanation	Note
1	T=timer	Specifies the stopping time.	Timer: 0.01 to 655.35 seconds Variable I/LI/I[]/LI[] can be used. (Units: 0.01 seconds)

Example

- (1) TIMER T=12.50
Stops for 12.5 seconds.

- (2) SET I002 5
TIMER T=I002
Stops for 0.05 seconds.

*(LABEL)

SUBSET	STANDARD	EXPANDED
Available	Available	Available

Function

Specifies the label for the jump.

Construction

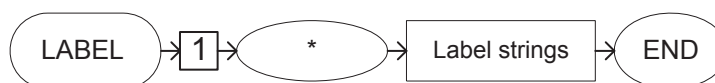

Explanation

1. *Label strings

Add the following tag.

No	Tag	Explanation	Note
1	*Label strings	Specifies the label strings.	String: 8 characters

Example

```

(1) NOP
    *1
    JUMP JOB:1 IF IN#(1)=ON
    JUMP JOB:2 IF IN#(2)=ON
    JUMP *1
    END
  
```

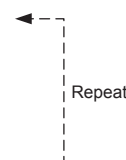

IF general input signal No.1 and No.2 are off, it loops infinitely between "*1" and "JUMP *1".



The label is effective only in the same job. It does not jump to the same label in other jobs.

'(COMMENT)

SUBSET	STANDARD	EXPANDED
Available	Available	Available

Function

Specifies the comment.

Construction

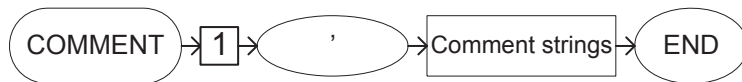

Explanation

1. 'Comment strings

Add the following tag.

No	Tag	Explanation	Note
1	'Comment strings	Specifies the comment.	String: 32 characters

Example

```

(1) NOP
    'Waiting Position
    MOVJ VJ=100.00
    MOVJ VJ=100.00
    MOVJ VJ=25.00
    'Welding Start
    ARCON ASF#(1)
    MOVL V=138
    'Welding end
    ARCOF
    MOVJ VJ=25.00
    'Waiting Position
    MOVJ VJ=100.00
    END
    The comment clarifies the job content.
  
```

RET

SUBSET	STANDARD	EXPANDED
Available	Available	Available

Function

Returns from the called job to the calling job.

Construction

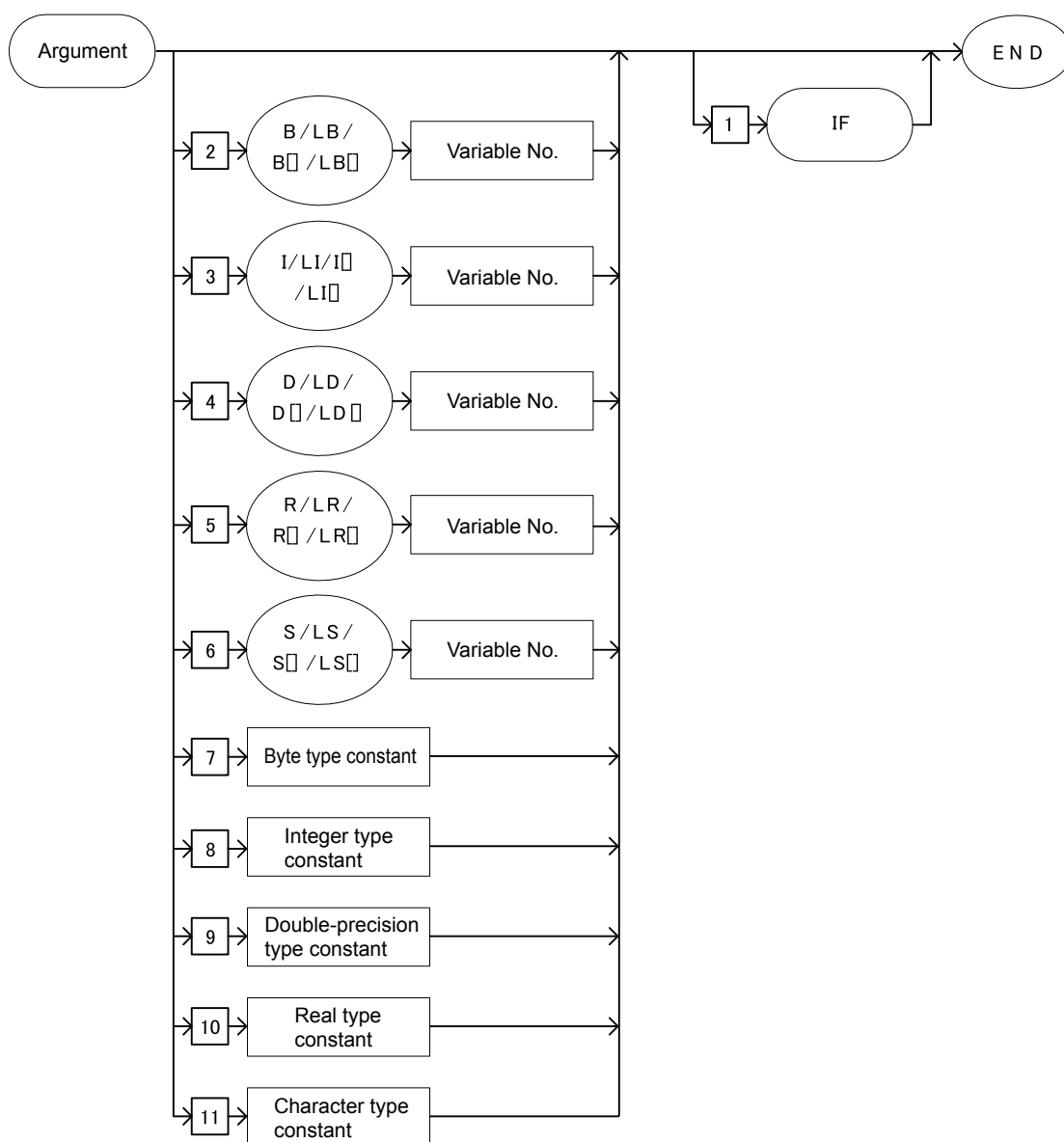

2.2 Control Instruction

Explanation

1. IF

The following tag can be added or omitted.

No	Tag	Explanation	Note
1	IF	Specifies the IF instruction.	Refer to <i>chapter 2.6 "Instruction Which Adheres to an Instruction"</i> at page 2-219.

Example

(1) RET IF IN#(12)=ON

If general input signal No.12 is on, it returns to the job of the call origin.

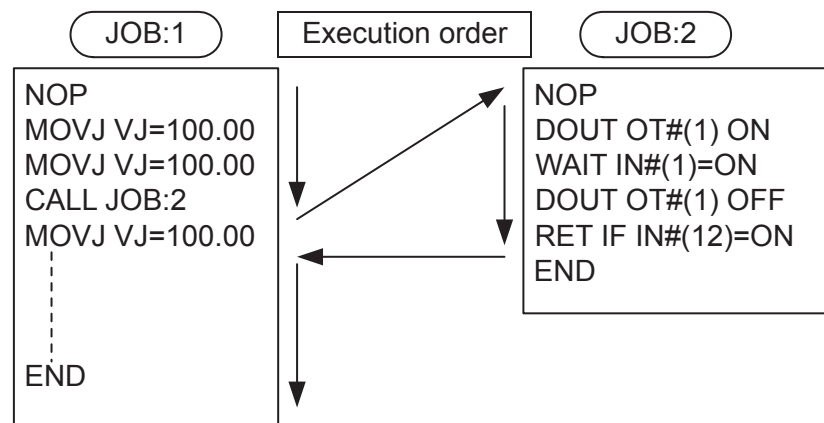

2. Return Value

The following tag can be added or omitted.

No	Tag	Explanation	Note
2 to 10	Variables other than position type variables and constants	Can return the return value to the call-origin job.	

Arguments can be added to the CALL instruction, and the return value can be returned with the RET instruction. Variables other than the position type variables (P variable, BP variable, EX variable, and PX variable) and constants can be returned as the return value.

At the call-origin job, the return value is received by the GETS instruction. For details, refer to "5. Argument (page 2-32)" in the explanation of the CALL instruction.

2.2 Control Instruction

Example

The following example is the case when the value returned from JOB: SAMPLE is received by I000.

```
CALL JOB: SAMPLE
GETS I000 $RV
```

In this case, at JOB: SAMPLE, the argument must be added to RET as follows:

```
NOOP
      :
RET  LI000
END
```

3. Related Instruction 1 GETARG

Add GETARG instruction. A description of this instruction was included in "DX100 OPTIONS INSTRUCTIONS FOR MACRO COMMAND FUNCTION (HW0485673)", but we also added it to this manual.

NOP

SUBSET	STANDARD	EXPANDED
Not available	Available	Available

Function

Carries out no operation.

Construction

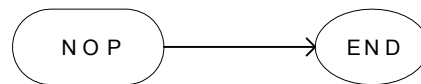

Example

(1) NOP
END

PAUSE

SUBSET	STANDARD	EXPANDED
Not available	Available	Available

Function

Stops the job temporarily.

Construction

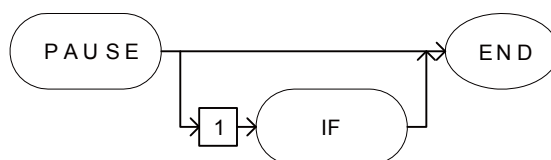

Explanation

1. IF

The following tag can be added or omitted.

No	Tag	Explanation	Note
1	IF	Specifies the IF instruction.	Refer to <i>chapter 2.6 "Instruction Which Adheres to an Instruction"</i> at <i>page 2-219</i> .

Example

- (1) PAUSE IF IN#(12)=ON
 Stops the job temporarily if general-purpose input signal number 12 is ON.

CWAIT

SUBSET	STANDARD	EXPANDED
Not available	Available	Available

Function

Waits for the next instruction line to be carried out.

CWAIT is used with the NWAIT tag, an additional item of a move instruction.

Construction

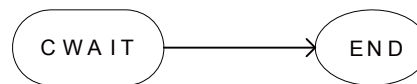

Example

(1) <Step>	<Instructions>
n	MOVL V=100 NWAIT
	DOUT OT#(1) ON
	CWAIT
	DOUT OT#(1) OFF
n+1	MOVL V=100

Turns ON the general-purpose output signal number 1 when the manipulator starts moving from the step n to the step n+1, and turns it OFF when the manipulator reaches the step n+1.

MSG

SUBSET	STANDARD	EXPANDED
Not available	Available	Available

Function

Displays the message.

Construction



Explanation

- "Message strings"

No	Tag	Explanation	Note
1	"Message strings"	Specifies the message.	String: 32 characters

ADVINIT

SUBSET	STANDARD	EXPANDED
Not available	Not available	Available

Function

When the same variable is used for multiple systems in the optional independent control function, ADVINIT controls the timing to change the variable data among the systems.

ADVINIT is an instruction used to control DX100 internal processing, therefore, executing this instruction does not affect the job.

Construction

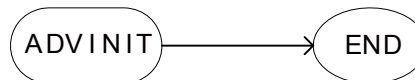

ADVSTOP

SUBSET	STANDARD	EXPANDED
Not available	Not available	Available

Function

When the same variable is used for multiple systems in the optional independent control function, ADVSTOP controls the access timing of the variable data among the systems.

ADVSTOP is an instruction used to control DX100 internal processing, therefore, executing this instruction does not affect the job.

Construction

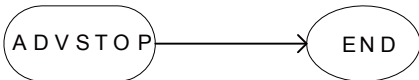

PRINT

SUBSET	STANDARD	EXPANDED
Not available	Available	Available

Function

Shows the specified character string and variable on the terminal display.

* Terminal display: Select {Main Menu}, {IN/OUT}, then {TERMINAL} to show it.

If the independent control function is enabled, the page is different for each task.

Construction

PRINT <Data 1> <Data 2>

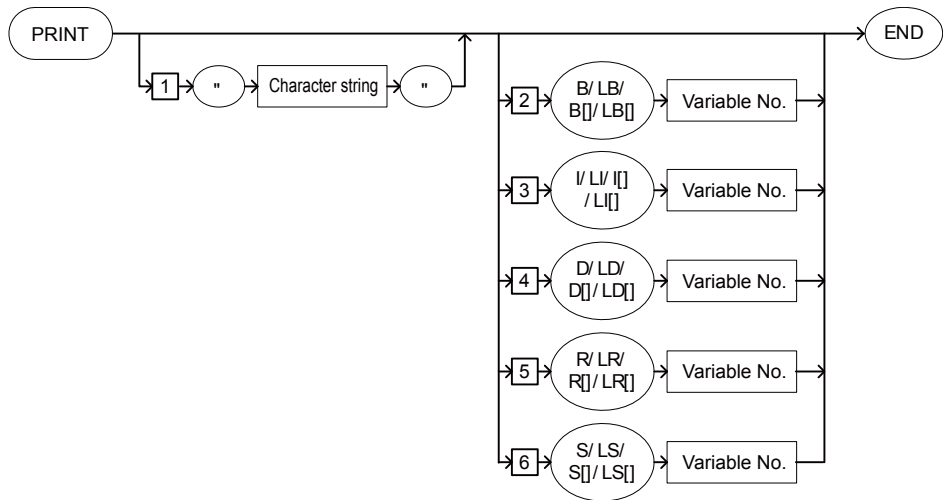

Explanation

1. Character string: Shows the specified character string on the terminal display.

The following tag can be added or omitted.

No	Tag	Explanation	Note
1	Character string	Specifies the character string to be shown on the terminal display.	<Data 1> String: 32 characters

2.2 Control Instruction

2. B Variable number / LB Variable number / B [Array number] / LB [Array number] / I Variable number / LI Variable number / I [Array number] / LI [Array number] / D Variable number / LD Variable number / D [Array number] / LD [Array number] / R Variable number / LR Variable number / R [Array number] / LR [Array number] / S Variable number / LS Variable number / S [Array number] / LS [Array number]

Select one of the above 2. to add or omit.

* To show the character string and variable on the terminal display, specify "character string %*" as the character string tag of the above 1. (%x (hexadecimal), %o (octal), %d (decimal), %s (character string), %f (real number), %e (exponent))

No	Tag	Explanation	Note
2	B Variable number/ LB Variable number/ B [Array number]/ LB [Array number]	Specifies the byte type variable number.	<Data 2>
3	I Variable number/ LI Variable number/ I [Array number]/ LI [Array number]	Specifies the integer type variable number.	<Data 2>
4	D Variable number/ LD Variable number/ D [Array number]/ LD [Array number]	Specifies the double-precision type variable number.	<Data 2>
5	R Variable number/ LR Variable number/ R [Array number]/ LR [Array number]	Specifies the real type variable number.	<Data 2>
6	S Variable number/ LS Variable number/ S [Array number]/ LS [Array number]	Specifies the character type variable number.	<Data 2>

2.2 Control Instruction

Example

- (1) PRINT "TEST"
Show TEST on the terminal display.

```

JOB CONTENT: MASTER
J: SAMPLE                S: 0000
CONTROL GROUP: R1       TOOL: **
0000 NOP
0001 PRINT "TEST"
0002 END

```

```

MOV C V=66

```

```

TERMINAL : MASTER
TEST

```

- (2) PRINT "TEST\n"
Show TEST on the terminal display, and start a new line.

```

JOB CONTENT: MASTER
J: SAMPLE                S: 0000
CONTROL GROUP: R1       TOOL: **
0000 NOP
0001 PRINT "TEST1 \n"
0002 PRINT "TEST2"
0003 END

```

```

MOV C V=66

```

```

TERMINAL : MASTER
TEST1
TEST2

```

- (3) PRINT "TEST%d" B001
Show TEST on the terminal display, and display the value of B001 in decimal notation.

```

JOB CONTENT: MASTER
J: SAMPLE                S: 0000
CONTROL GROUP: R1       TOOL: **
0000 NOP
0001 PRINT "TEST %d" B001
0002 END

```

```

MOV C V=66

```

```

TERMINAL : MASTER
TEST 10

```

DX100

2.2 Control Instruction

(4) PRINT B001

Show the value of B001 on the terminal display.

```
JOB CONTENT: MASTER
J: SAMPLE                S: 0000
CONTROL GROUP: R1       TOOL: **
0000 NOP
0001 PRINT B001
0002 END

MOV C V=66

TERMINAL : MASTER
10
```



CLS

SUBSET	STANDARD	EXPANDED
Not available	Available	Available

Function

Deletes the character string shown on the terminal display.

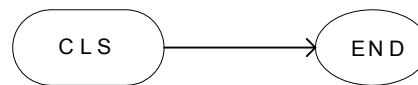
Construction



Example

(1) CLS

Deletes the character string shown on the terminal display.

```

JOB CONTENT: MASTER
J: SAMPLE                S: 0000
CONTROL_GROUP: R1       TOOL: **
0000 NOP
0001 CLS
0002 END

MOV C V=66

TERMINAL : MASTER
TEST
TEST
TEST
TEST
TEST
  
```

<Before executing CLS instruction>

```

JOB CONTENT: MASTER
J: SAMPLE                S: 0000
CONTROL_GROUP: R1       TOOL: **
0000 NOP
0001 CLS
0002 END

MOV C V=66

TERMINAL : MASTER
  
```

<After executing CLS instruction>

ABORT

SUBSET	STANDARD	EXPANDED
Not available	Available	Available

Function

Suspends playback, and shows “Robot is stopped by execution ABORT command.” on the human interface display area.

After the playback is suspended by ABORT instruction, it will not restart until the job is reselected on the JOB SELECT window.

Construction

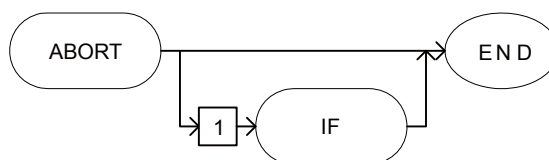

Explanation

1. IF

The following tag can be added or omitted.

No	Tag	Explanation	Note
1	IF	Specifies the IF instruction.	Refer to <i>chapter 2.6 "Instruction Which Adheres to an Instruction"</i> at page 2-219.

Example

- (1) ABORT
Stops the playback of job, and displays the message “Robot is stopped by execution ABORT command.”
- (2) ABORT IF B000=1
Stops the playback of job when B000 is 1, and displays the message “Robot is stopped by execution ABORT command.”

SETUALM

SUBSET	STANDARD	EXPANDED
Not available	Available	Available

Function

Generates an alarm with any given number, name and subcode.

Construction

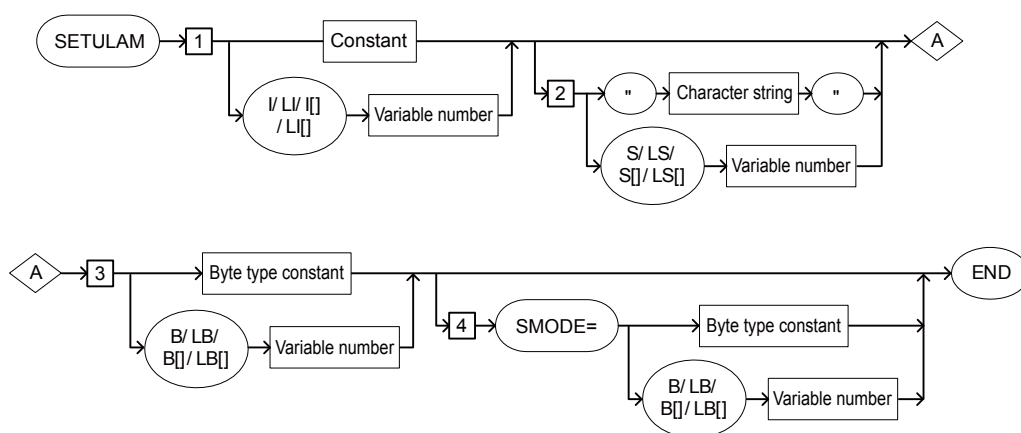

Explanation

1. Alarm Code

Add the following tag.

No	Tag	Explanation	Note
1	I Variable number/ LI Variable number/ I [Variable number]/ LI [Variable number]/ [Constant]	Specifies the integer type variable number.	Number: 8000 to 8999

2. Alarm Name

The following tag can be added or omitted.

No	Tag	Explanation	Note
2	S Variable number/ LS Variable number/ S [Array number]/ LS [Array number]/ [Character string]	Specifies the alarm name.	String: 32 characters S variable: 16 characters

DX100

2.2 Control Instruction

3. Subcode

Add the following tag.

No	Tag	Explanation	Note
3	B Variable number/ LB Variable number/ B [Array number]/ LB [Array number]/ [Byte type constant]	Specifies the byte type variable number.	Number: 0 to 255

4. SMODE (Operation Stop Mode)

The following tag can be added or omitted.

No	Tag	Explanation	Note
4	B Variable number/ LB Variable number/ B [Array number]/ LB [Array number]/ [Byte type constant]	Specifies SMODE (operation stop mode).	Number: 0: All Tasks Job Stop 1: No Job Stop 2: Each Task Job Stop

Example

- (1) SETUALM 8000 0
The alarm with the alarm number 8000 and subcode 0 occurs.
- (2) SETUALM 8000 "ALM" 0 SMODE=1
The alarm with the alarm number 8000, alarm name ALM, and subcode 0 occurs.
If SMODE is 1, the job does not stop.



By this instruction, the execution of job is stopped according to SMODE after the alarm occurs.

It does not guarantee that the execution of job stops immediately after the instruction is executed.

DIALOG

SUBSET	STANDARD	EXPANDED	PARAMETER
Not available	Available	Available	S2C400

Function

Shows the dialog during the execution of job.

If the current display is not the PLAYBACK window, the PLAYBACK window is displayed when the dialog is shown by the execution of DIALOG instruction.

The job does not proceed while the dialog is shown (waiting for button input).

Construction

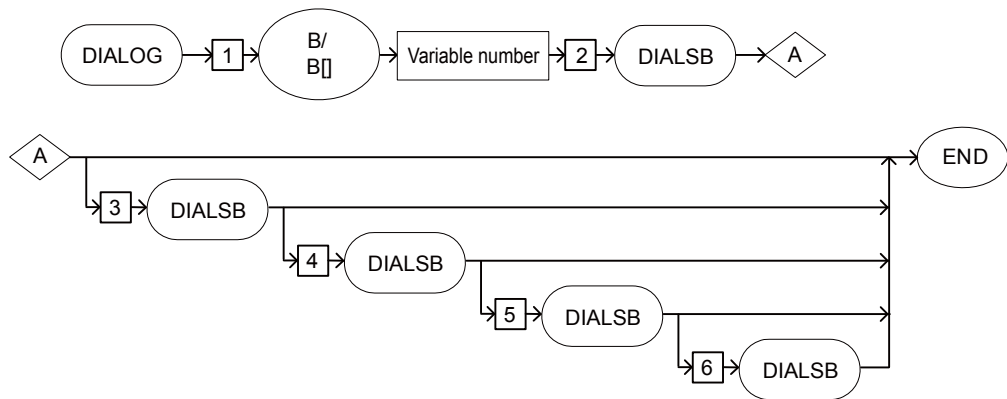

Explanation

1. B Variable number / B [Array number]: Selection result

Select the first, second, third, fourth, and fifth button to store 1, 2, 3, 4, and 5 in the specified B variable respectively.

Make sure to add the following tag.

No	Tag	Explanation	Note
1	B Variable number/ B [Array number]	Specifies the byte type variable number.	

2. DIALSB (First)

Shows a message and one button in the dialog.
For details, refer to "DIALSB".

DX100

2.2 Control Instruction

Make sure to add the following tag.

No	Tag	Explanation	Note
2	DIALSB	Select the button shown by this instruction to store 1 in the selection result.	

3. DIALSB (Second and after)

Adds a message and one button in the dialog.
For details, refer to "DIALSB".

The following tag can be added or omitted.

No	Tag	Explanation	Note
3	DIALSB	Select the button shown by this instruction to store 2 in the selection result.	
4	DIALSB	Select the button shown by this instruction to store 3 in the selection result.	
5	DIALSB	Select the button shown by this instruction to store 4 in the selection result.	
6	DIALSB	Select the button shown by this instruction to store 5 in the selection result.	

Example

The variable settings are shown below.

BYTE VARIABLE			BYTE VARIABLE			STRING VARIABLE	
NO.		CONTENTS	NO.		CONTENTS	NO.	CONTENTS
B000	0	0000_0000	B014	1	0000_0001	S000	MESSAGE1
B001	1	0000_0001	B015	10	0000_1010	S001	B1
B002	1	0000_0001	B016	2	0000_0010	S002	MESSEAGE2
B003	1	0000_0001	B017	10	0000_1010	S003	B2
B004	2	0000_0010	B018	3	0000_0011	S004	MESSEAGE3
B005	1	0000_0001	B019	10	0000_1010	S005	B3
B006	3	0000_0011	B020	4	0000_0100	S006	MESSEAGE4
B007	1	0000_0001	B021	0	0000_0000	S007	B4
B008	4	0000_0100	B022	0	0000_0000	S008	MESSEAGE5
B009	1	0000_0001	B023	0	0000_0000	S009	B5
B010	5	0000_0101	B024	0	0000_0000	S010	
B011	1	0000_0001	B025	0	0000_0000	S011	
B012	6	0000_0110	B026	0	0000_0000	S012	
B013	10	0000_1010	B027	0	0000_0000	S013	

- (1) DIALOG B000 DIALSB B001 B002 S000 B003 B004 S001
Shows the message of S000 at coordinates (B001, B002), and shows the button with the name of S001 at coordinates (B003, B004).

2.2 Control Instruction

When the button is clicked, the result is stored in B000.



- (2) DIALOG B000 DIALSB B001 B002 S000 B003 B004 S001
DIALSB B005 B006 S002 B007 B008 S003

Shows the message of S000 at coordinates (B001, B002), and shows the button with the name of S001 at coordinates (B003, B004).

Shows the message of S002 at coordinates (B005, B006), and shows the button with the name of S003 at coordinates (B007, B008).

When the button is clicked, the result is stored in B000.

(With B1, 1 is stored. With B2, 2 is stored.)



2.2 Control Instruction

- (3) DIALOG B000 DIALSB B001 B002 S000 B003 B004 S001
 DIALSB B005 B006 S002 B007 B008 S003
 DIALSB B009 B010 S004 B011 B012 S005
 DIALSB B013 B014 S006 B015 B016 S007
 DIALSB B017 B018 S008 B019 B020 S009

Shows the message of S000 at coordinates (B001, B002), and shows the button with the name of S001 at coordinates (B003, B004).

Shows the message of S002 at coordinates (B005, B006), and shows the button with the name of S003 at coordinates (B007, B008).

Shows the message of S004 at coordinates (B009, B010), and shows the button with the name of S005 at coordinates (B011, B012).

Shows the message of S006 at coordinates (B013, B014), and shows the button with the name of S007 at coordinates (B015, B016).

Shows the message of S008 at coordinates (B017, B018), and shows the button with the name of S009 at coordinates (B019, B020).

When the button is clicked, the result is stored in B000.
 (1, 2, 3, 4, and 5 is stored with B1, B2, B3, B4, and B5, respectively.)

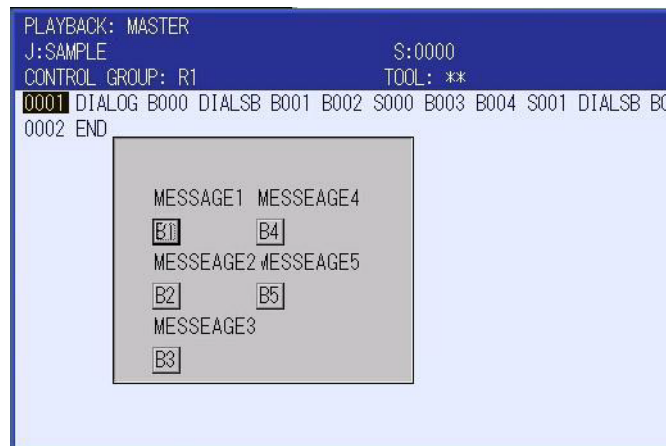

DIALSB

SUBSET	STANDARD	EXPANDED
Not available	Available	Available

Function

Specifies the structure of the dialog (the display position of the message and button) shown by the DIALOG instruction.

* Can be selected only in the DIALOG instruction.

Construction

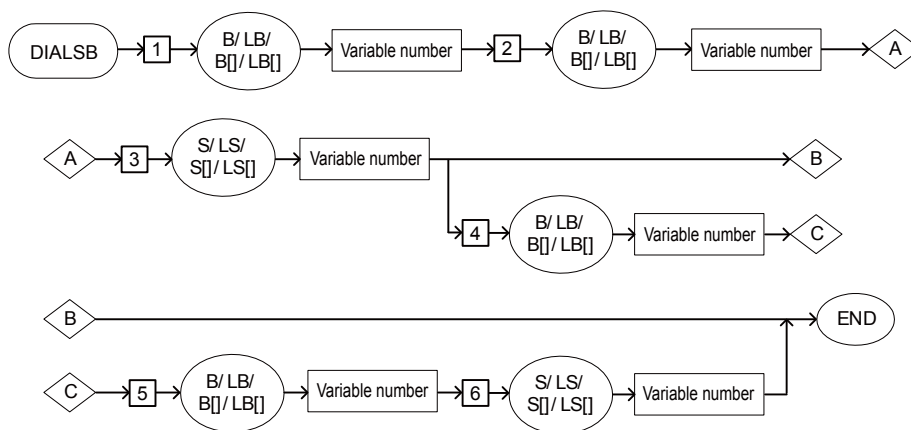

Explanation

1. B Variable number / LB Variable number / B [Array number] / LB [Array number]: Message X coordinates

Add the following tag.

No	Tag	Explanation	Note
1	B Variable number/ LB Variable number/ B [Array number]/ LB [Array number]	Specifies the byte type variable number.	

DX100

2.2 Control Instruction

2. B Variable number / LB Variable number / B [Array number] / LB [Array number]: Message Y coordinates

Add the following tag.

No	Tag	Explanation	Note
2	B Variable number/ LB Variable number/ B [Array number]/ LB [Array number]	Specifies the byte type variable number.	

3. S Variable number / LS Variable number / S [Array number] / LS [Array number]: Message character string

Add the following tag.

No	Tag	Explanation	Note
3	S Variable number/ LS Variable number/ S [Array number]/ LS [Array number]	Specifies the character string type variable number.	

4. B Variable number / LB Variable number / B [Array number] / LB [Array number]: Button X coordinates

Make sure to add the following tag for the first DIALSB in the DIALOG instruction.

For the second and after, the following tag can be added or omitted.

No	Tag	Explanation	Note
4	B Variable number/ LB Variable number/ B [Array number]/ LB [Array number]	Specifies the byte type variable number.	

5. B Variable number / LB Variable number / B [Array number] / LB [Array number]: Button Y coordinates

Make sure to add the following tag for the first DIALSB in the DIALOG instruction.

For the second and after, the following tag can be added or omitted.

No	Tag	Explanation	Note
5	B Variable number/ LB Variable number/ B [Array number]/ LB [Array number]	Specifies the byte type variable number.	

2.2 Control Instruction

6. S Variable number / LS Variable number / S [Array number] / LS [Array number]: Button character string

Make sure to add the following tag for the first DIALSB in the DIALOG instruction.

For the second and after, the following tag can be added or omitted.

No	Tag	Explanation	Note
3	S Variable number/ LS Variable number/ S [Array number]/ LS [Array number]	Specifies the character string type variable number.	

2.3 Operating Instruction

CLEAR

SUBSET	STANDARD	EXPANDED
Available	Available	Available

Function

In Data 1, the variable content from the specified number on, is cleared to 0 only by the amount specified in Data 2.

Construction

CLEAR <Data 1> <Data 2>

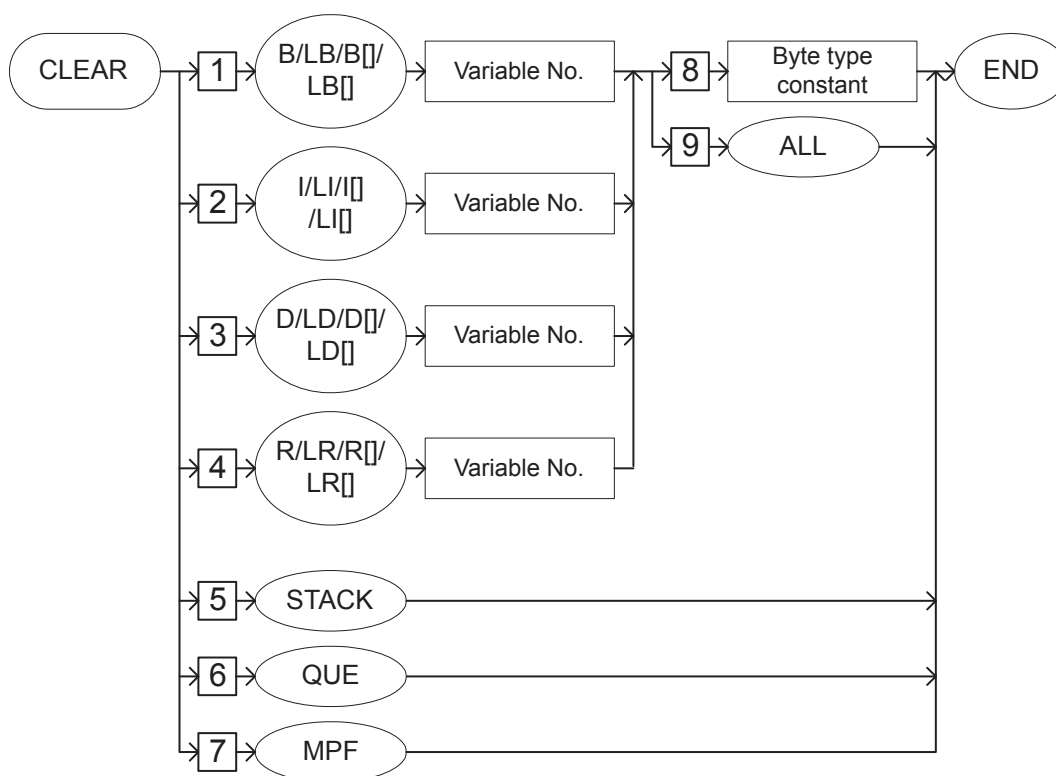

2.3 Operating Instruction

Explanation

1. B Variable number /LB Variable number /B [Array number] /LB [Array number] /I Variable number /LI Variable number /I [Array number] /LI [Array number] /D Variable number /LD Variable number /D [Array number] /LD [Array number] /R Variable number /LR Variable number /R [Array number] /LR [Array number] /STACK/QUE/MPF

Choose one of the tags from the following table.

No	Tag	Explanation	Note
1	B Variable number/ LB Variable number/ B [Array number]/ LB [Array number]	Specifies the number of the byte type variable to be cleared.	< Data 1 >
2	I Variable number/ LI Variable number/ I [Array number]/ LI [Array number]	Specifies the number of the integer type variable to be cleared.	< Data 1 >
3	D Variable number/ LD Variable number/ D [Array number]/ LD [Array number]	Specifies the number of the double precision type variable to be cleared.	< Data 1 >
4	R Variable number/ LR Variable number/ R [Array number]/ LR [Array number]	Specifies the number of the real type variable to be cleared.	< Data 1 >
5	STACK	There are eight stacks, and they store the called position.	< Data 1 >
6	QUE	Clears all the job queues.	<Data 1> Available only with the job queue function (option: S2C503)
7	MPF	Clears all the contents of the memo play file.	<Data 1> Available only with the optional memo play function.



About the job call stack

There are eight stacks, and they store the called position.

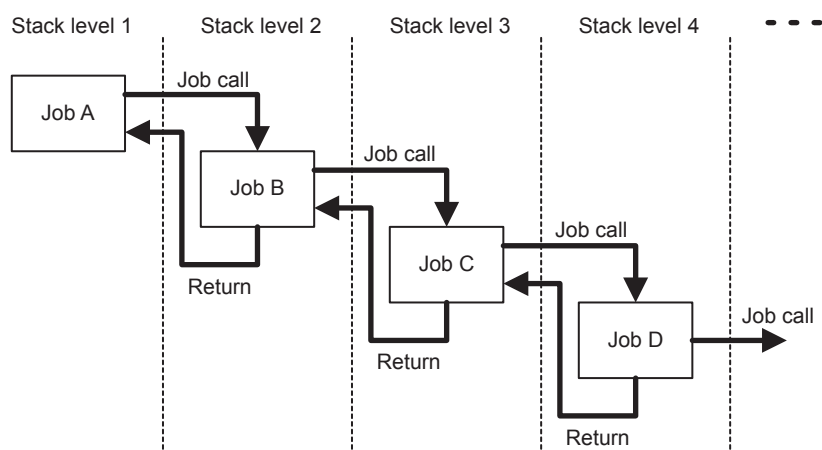

2. Byte type constant /ALL

When a B Variable number, LB Variable number, B [Array number], LB [Array number], I Variable number, LI Variable number, I [Array number], LI [Array number], D Variable number, LD Variable number, D [Array number], LD [Array number], R Variable number, LR Variable number, R [Array number], or LR [Array number] is selected from the table in part 1 of this Explanation, choose one of the tags from the following table.

No	Tag	Explanation	Note
8	Byte type constant	Specifies the number cleared starting from the number of the specified variable.	
9	ALL	All variables starting from the number of the specified variable are cleared.	

Example

- (1) CLEAR B003 10
The content of the variables from B003 to B0012 are cleared to 0.
- (2) CLEAR D010 ALL
The content of all the double precision type variables is cleared to 0 starting from D010.
- (3) CLEAR STACK
All the job call stacks are cleared.

2.3 Operating Instruction

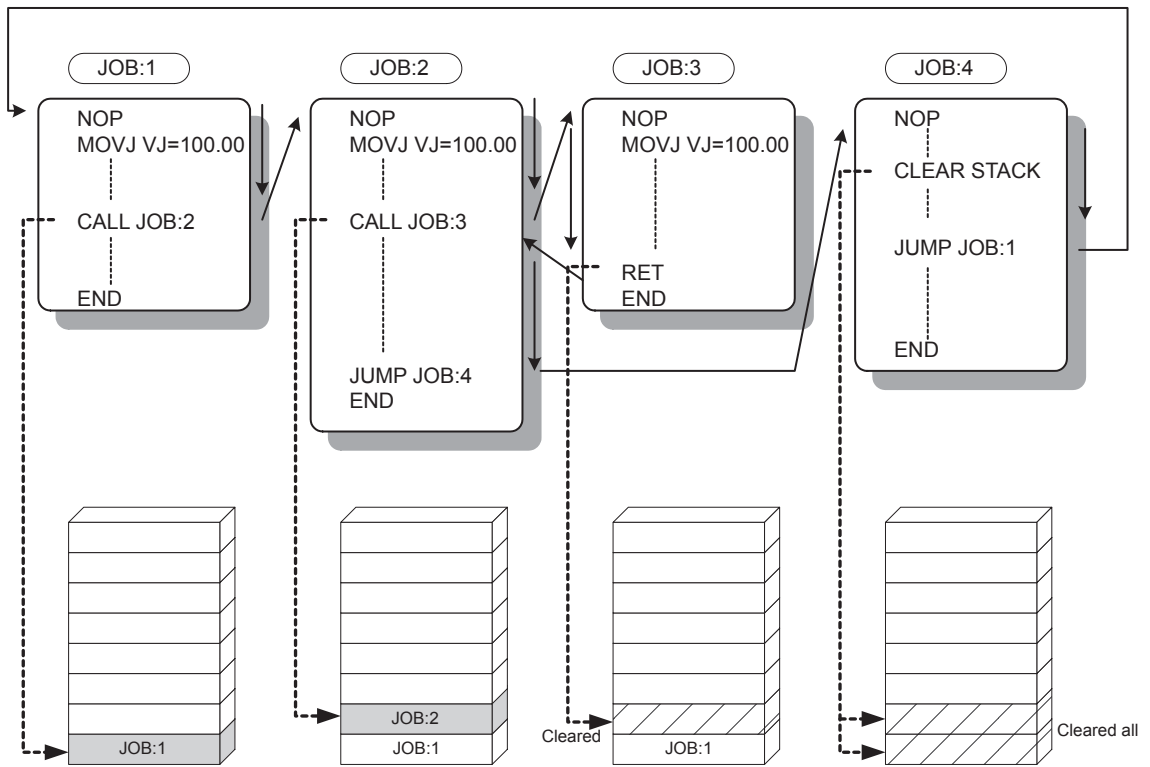

INC

SUBSET	STANDARD	EXPANDED
Available	Available	Available

Function

Adds one to the content of the specified variable.

Construction

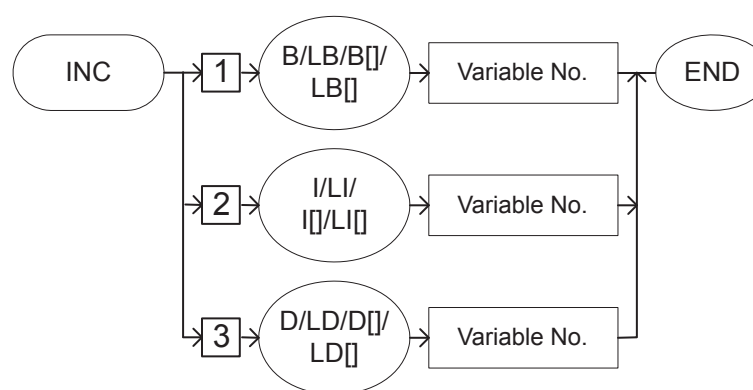

Explanation

1. B Variable number /LB Variable number /B [Array number] /LB [Array number] /I Variable number/ LI Variable number /I [Array number] /LI [Array number] /D Variable number/ LD Variable number /D [Array number] /LD [Array number]

Choose one of the tags from the following table.

No	Tag	Explanation	Note
1	B Variable number/ LB Variable number/ B [Array number]/ LB [Array number]	Specifies the number of the byte type variable.	
2	I Variable number/ LI Variable number/ I [Array number]/ LI [Array number]	Specifies the number of the integer type variable.	
3	D Variable number/ LD Variable number/ D [Array number]/ LD [Array number]	Specifies the number of the double precision type variable.	

2.3 Operating Instruction

Example

```
(1) NOP
    SET B000 200
    *1 ← - - - - -
    MOVJ VJ=100.00
    MOVJ VJ=50.00
    |
    |
    INC B000 ← - - - - -
    JUMP *1 IF B000=0 - - -
    END
```

1 is repeatedly added to B000 until it reaches 200.

1 is added to B000.

DEC

SUBSET	STANDARD	EXPANDED
Not available	Available	Available

Function

Subtracts 1 from a specified variable.

Construction

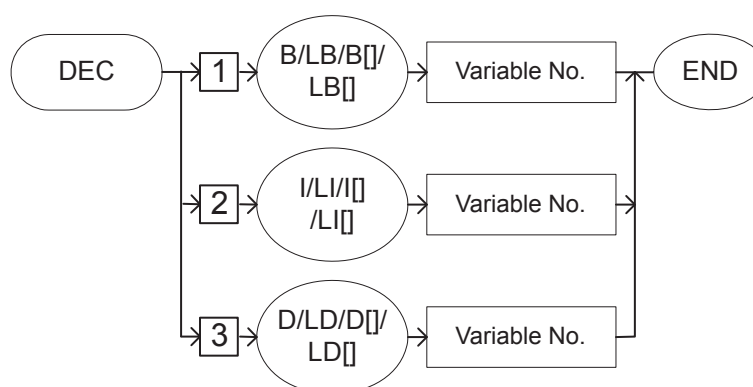

Explanation

1. B Variable number/LB Variable number/B [Array number]/LB [Array number]/I Variable number/LI Variable number/I [Array number]/LI [Array number]/D Variable number/LD Variable number/D [Array number]/LD [Array number]

Choose one of the tags from the following table.

No.	Tag	Explanation	Note
1	B Variable number/ LB Variable number/ B [Array number]/ LB [Array number]	Specifies the number of the byte type variable from which 1 is subtracted.	
2	I Variable number/ LI Variable number/ I [Array number]/ LI [Array number]	Specifies the number of the integer type variable from which 1 is subtracted.	
3	D Variable number/ LD Variable number/ D [Array number]/ LD [Array number]	Specifies the number of the double-precision type variable from which 1 is subtracted.	

2.3 Operating Instruction

Example

```
(1) NOP
    SET B000 200
    *1 ← -----
    MOVJ VJ=100.00
    MOVJ VJ=50.00
    .
    .
    .
    DEC B000 ← -----
    JUMP *1 IF B000=0 -----
    END
```

1 is repeatedly subtracted from B000 until it reaches 0.

1 is subtracted from B000.

SET

SUBSET	STANDARD	EXPANDED
Available	Available	Available

Function

Sets Data 2 to Data 1.

Construction

SET <Data 1> <Data 2>

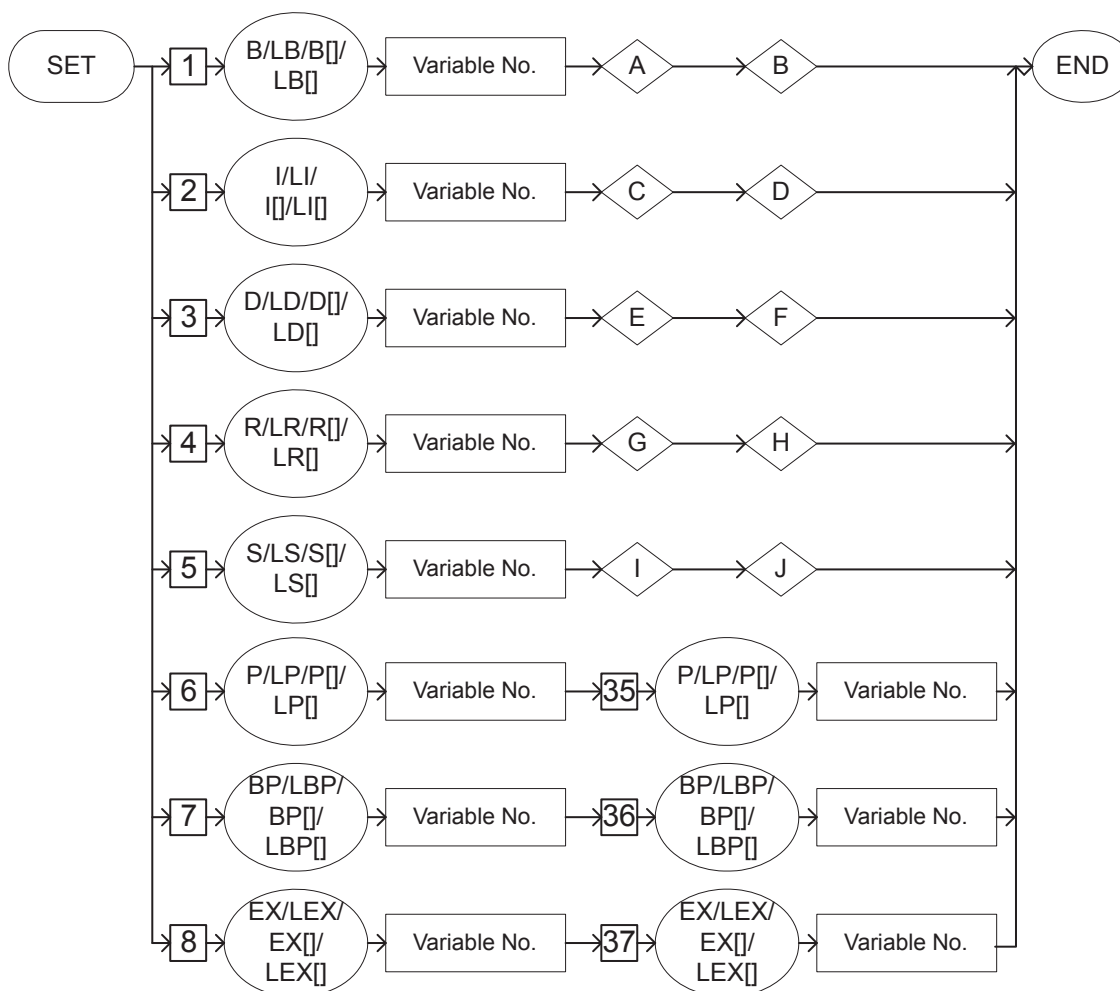

2.3 Operating Instruction

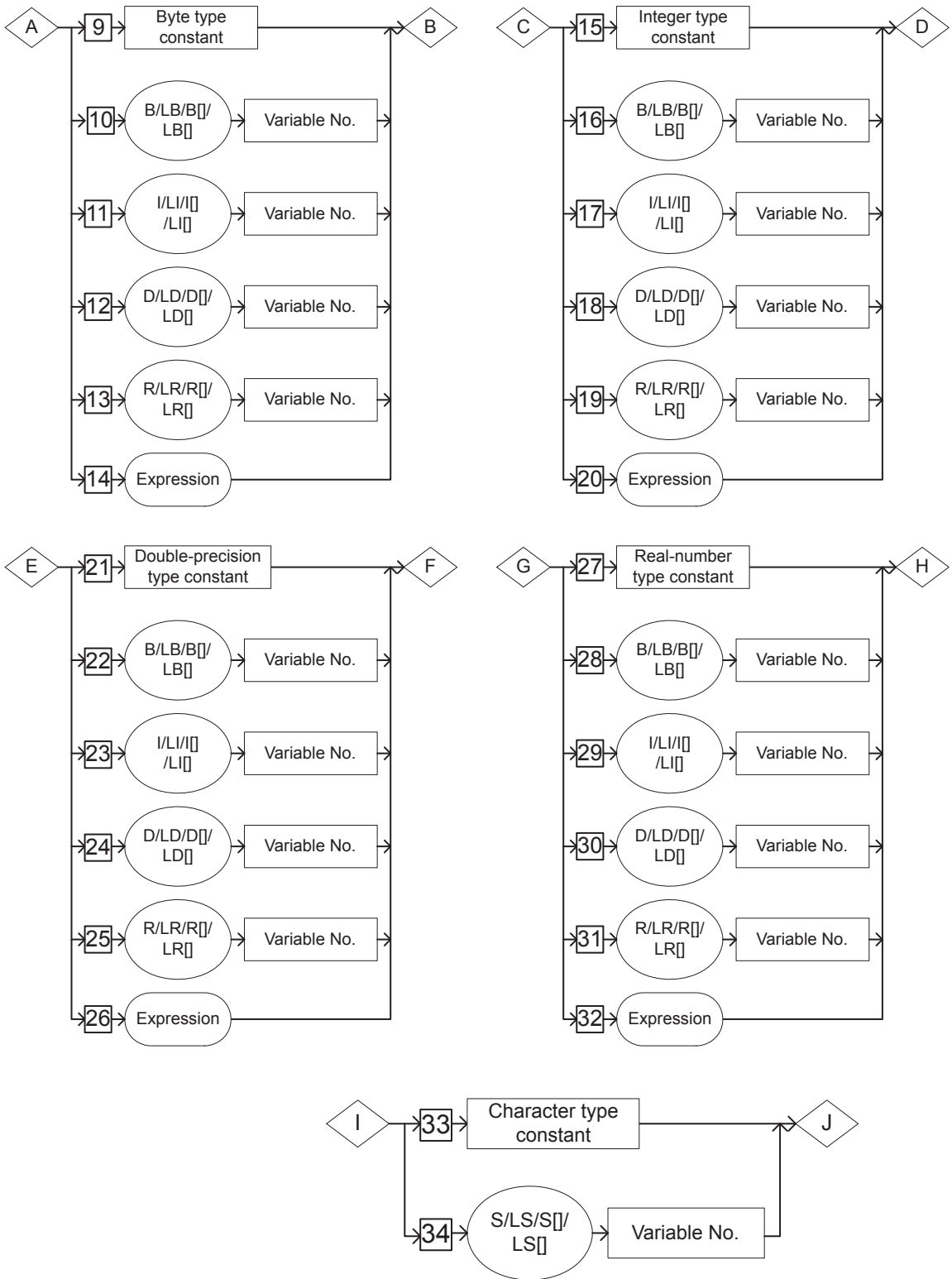

2.3 Operating Instruction

Explanation

1. B Variable number /LB Variable number /B [Array number] /LB [Array number] /I Variable number /LI Variable number /I [Array number] /LI [Array number] /D Variable number /LD Variable number /D [Array number] /LD [Array number] /R Variable number /LR Variable number /R [Array number] /LR [Array number] /S Variable number /LS Variable number /S [Array number] /LS [Array number] /P Variable number /LP Variable number /P [Array number] /LP [Array number] /BP Variable number /LBP Variable number /BP [Array number] /LBP [Array number] /EX Variable number /LEX Variable number /EX [Array number] /LEX [Array number]

Choose one of the tags from the following table.

No	Tag	Explanation	Note
1	B Variable number/ LB Variable number/ B [Array number]/ LB [Array number]	Specifies the number of the byte type variable to which data is set.	< Data1>
2	I Variable number/ LI Variable number/ I [Array number]/ LI [Array number]	Specifies the number of the integer type variable to which data is set.	< Data 1>
3	D Variable number/ LD Variable number/ D [Array number]/ LD [Array number]	Specifies the number of the double precision type variable to which data is set.	< Data 1>
4	R Variable number/ LR Variable number/ R [Array number]/ LR [Array number]	Specifies the number of the real type variable to which data is set.	< Data 1>
5	S Variable number/ LS Variable number/ S [Array number]/ LS [Array number]	Specifies the number of the character type variable to which data is set.	< Data 1>
6	P Variable number/ LP Variable number/ P [Array number]/ LP [Array number]	Specifies the number of the robot axis positional variable to which data is set.	< Data 1>
7	BP Variable number/ LBP Variable number/ BP [Array number]/ LBP [Array number]	Specifies the number of the base axis positional variable to which data is set.	< Data 1>
8	EX Variable number/ LEX Variable number/ EX [Array number]/ LEX [Array number]	Specifies the number of the station axis positional variable to which data is set.	< Data 1>

2.3 Operating Instruction

2. Byte type constant /B Variable number /LB Variable number /B [Array number] /LB [Array number] /I Variable number /LI Variable number /I [Array number] /LI [Array number] /D Variable number /LD Variable number /D [Array number] /LD [Array number] /R Variable number /LR Variable number /R [Array number] /LR [Array number]/Expression

When a B Variable number, LB Variable number, B [Array number], or LB [Array number] is selected from the table part 1 of this Explanation, choose one of the tags from the following table.

No	Tag	Explanation	Note
9	Byte type constant	Specifies the byte type constant.	< Data 2>
10	B Variable number/ LB Variable number/ B [Array number]/ LB [Array number]	Specifies the number of the byte type variable.	< Data 2>
11	I Variable number/ LI Variable number/ I [Array number]/ LI [Array number]	Specifies the number of the integer type variable.	< Data 2>
12	D Variable number/ LD Variable number/ D [Array number]/ LD [Array number]	Specifies the number of the double precision type variable.	< Data 2>
13	R Variable number/ LR Variable number/ R [Array number]/ LR [Array number]	Specifies the number of the real type variable.	< Data 2>
14	Expression	Specifies the expression.	<Data 2> For details of setting the expression, refer to <i>chapter 1.4 "Registration of Expression"</i> at page 1-7.

3. Integer type constant /B Variable number /LB Variable number /B [Array number] /LB [Array number] /I Variable number /LI Variable number /I [Array number] /LI [Array number] /D Variable number /LD Variable number /D [Array number] /LD [Array number] /R Variable number /LR Variable number /R [Array number] /LR [Array number]/ Expression

2.3 Operating Instruction

When an I Variable number, LI Variable number, I [Array number], or LI [Array number] is selected from the table in part 1 of this Explanation, choose one of the tags from the following table.

No	Tag	Explanation	Note
15	Integer type constant	Specifies the integer type constant.	< Data 2>
16	B Variable number/ LB Variable number/ B [Array number]/ LB [Array number]	Specifies the number of the byte type variable.	< Data 2>
17	I Variable number/ LI Variable number/ I [Array number]/ LI [Array number]	Specifies the number of the integer type variable.	< Data 2>
18	D Variable number/ LD Variable number/ D [Array number]/ LD [Array number]	Specifies the number of the double precision type variable.	< Data 2>
19	R Variable number/ LR Variable number/ R [Array number]/ LR [Array number]	Specifies the number of the real type variable.	< Data 2>
20	Expression	Specifies the expression.	<Data 2> For details of setting the expression, refer to <i>chapter 1.4 "Registration of Expression" at page 1-7.</i>

4. Double precision type constant /B Variable number / LB Variable number /B [Array number] /LB [Array number] /I Variable number /LI Variable number /I [Array number] /LI [Array number] /D Variable number /LD Variable number /D [Array number] /LD [Array number] /R Variable number /LR Variable number /R [Array number] /LR [Array number] / Expression

When a D Variable number, LD Variable number, D [Array number], or LD [Array number] is selected from the table in part 1 of this Explanation, choose one of the tags from the following table.

No	Tag	Explanation	Note
21	Double precision type constant	Specifies the double precision type constant.	< Data 2>
22	B Variable number/ LB Variable number/ B [Array number]/ LB [Array number]	Specifies the number of the byte type variable.	< Data 2>
23	I Variable number/ LI Variable number/ I [Array number]/ LI [Array number]	Specifies the number of the integer type variable.	< Data 2>

2.3 Operating Instruction

No	Tag	Explanation	Note
24	D Variable number/ LD Variable number/ D [Array number]/ LD [Array number]	Specifies the number of the double precision type variable.	< Data 2>
25	R Variable number/ LR Variable number/ R [Array number]/ LR [Array number]	Specifies the number of the real type variable.	< Data 2>
26	Expression	Specifies the expression.	<Data 2> For details of setting the expression, refer to <i>chapter 1.4 "Registration of Expression" at page 1-7.</i>

5. Real type constant /B Variable number /LB Variable number /B [Array number] /LB [Array number] /I Variable number /LI Variable number /I [Array number] /LI [Array number] /D Variable number /LD Variable number /D [Array number] /LD [Array number] /R Variable number /LR Variable number /R [Array number] /LR [Array number]/Expression

When an R Variable number, LR Variable number, R [Array number], or LR [Array number] is selected from the table in part 1 of this Explanation, choose one of the tags from the following table.

No	Tag	Explanation	Note
27	Real type constant	Specifies the real type constant.	< Data 2>
28	B Variable number/ LB Variable number/ B [Array number]/ LB [Array number]	Specifies the number of the byte type variable.	< Data2>
29	I Variable number/ LI Variable number/ I [Array number]/ LI [Array number]	Specifies the number of the integer type variable.	< Data 2>
30	D Variable number/ LD Variable number/ D [Array number]/ LD [Array number]	Specifies the number of the double precision type variable.	< Data 2>
31	R Variable number/ LR Variable number/ R [Array number]/ LR [Array number]	Specifies the number of the real type variable.	< Data 2>
32	Expression	Specifies the expression.	<Data 2> For details of setting the expression, refer to <i>chapter 1.4 "Registration of Expression" at page 1-7.</i>

2.3 Operating Instruction

6. Character type constant /S Variable number /LS Variable number /S [Array number] /LS [Array number]

When an S Variable number, LS Variable number, S [Array number], or LS [Array number] is selected from the table in part 1 of this Explanation, choose one of the tags from the following table.

No	Tag	Explanation	Note
33	Character type constant	Specifies the character type data.	< Data 2>
34	S Variable number/ LS Variable number/ S [Array number]/ LS [Array number]	Specifies the number of the character type variable.	< Data 2>

7. P Variable number /LP Variable number /P [Array number] /LP [Array number]

When a P Variable number, LP Variable number, P [Array number], or LP [Array number] is selected from the table in part 1 of this Explanation, add the following tag.

No	Tag	Explanation	Note
35	P Variable number/ LP Variable number/ P [Array number]/ LP [Array number]	Specifies the number of the robot axis position variable.	< Data 2>

8. BP Variable number /LBP Variable number /BP [Array number] /LBP [Array number]

When a BP Variable number, LBP Variable number, BP [Array number], or LBP [Array number] is selected from the table in part 1 of this Explanation, add the following tag.

No	Tag	Explanation	Note
36	BP Variable number/ LBP Variable number/ BP [Array number]/ LBP [Array number]	Specifies the number of the base axis position variable.	< Data 2>

2.3 Operating Instruction

9. EX Variable number /LEX Variable number /EX [Array number] /LEX [Array number]

When an EX Variable number, LEX Variable number, EX [Array number], or LEX [Array number] is selected from the table in part 1 of this Explanation, add the following tag.

No	Tag	Explanation	Note
37	EX Variable number/ LEX Variable number/ EX [Array number]/ LEX [Array number]	Specifies the number of the station axis position variable.	< Data 2>

Example

- (1) SET B000 0
0 is set in B000.

- (2) SET P000 P001
The content of P001 is set in P000.

ADD

SUBSET	STANDARD	EXPANDED
Available	Available	Available

Function

Adds Data 1 and Data 2, and stores the result in Data 1.

Construction

Add <Data 1> <Data 2>

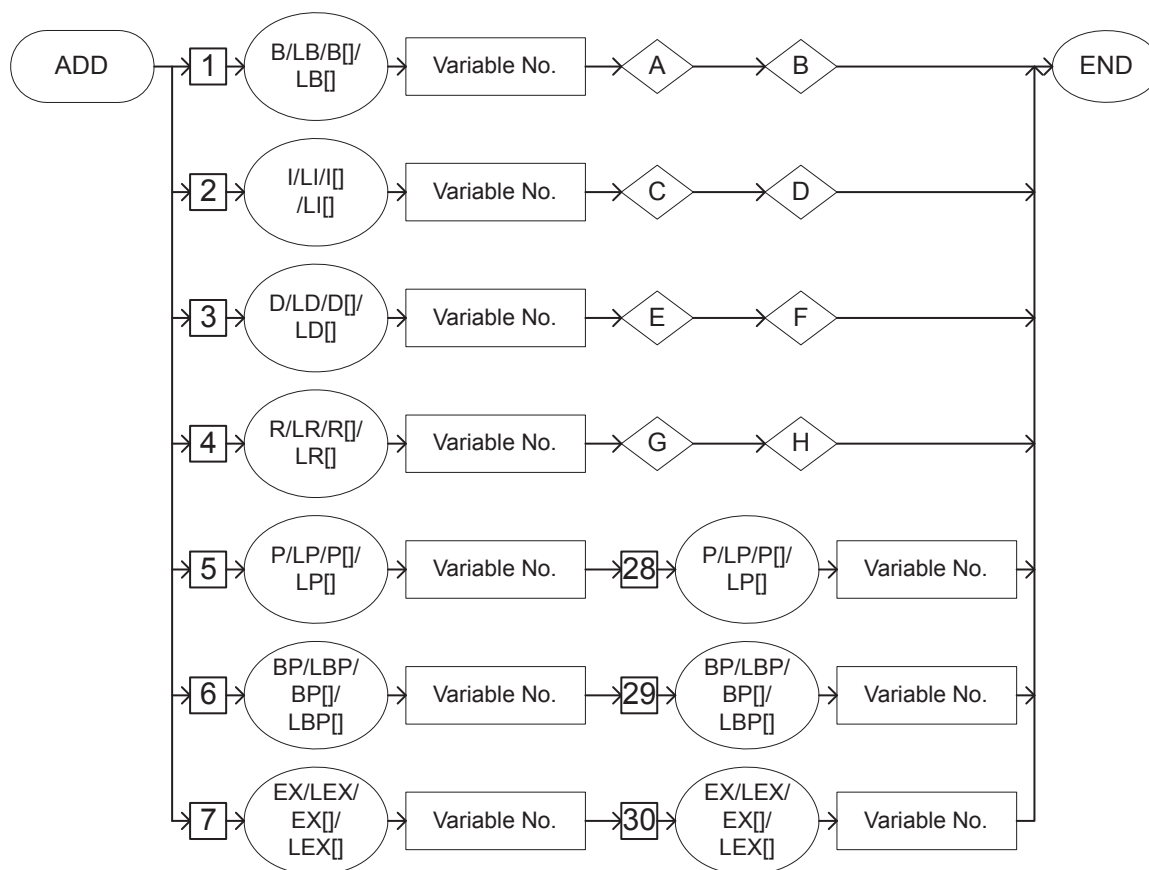

2.3 Operating Instruction

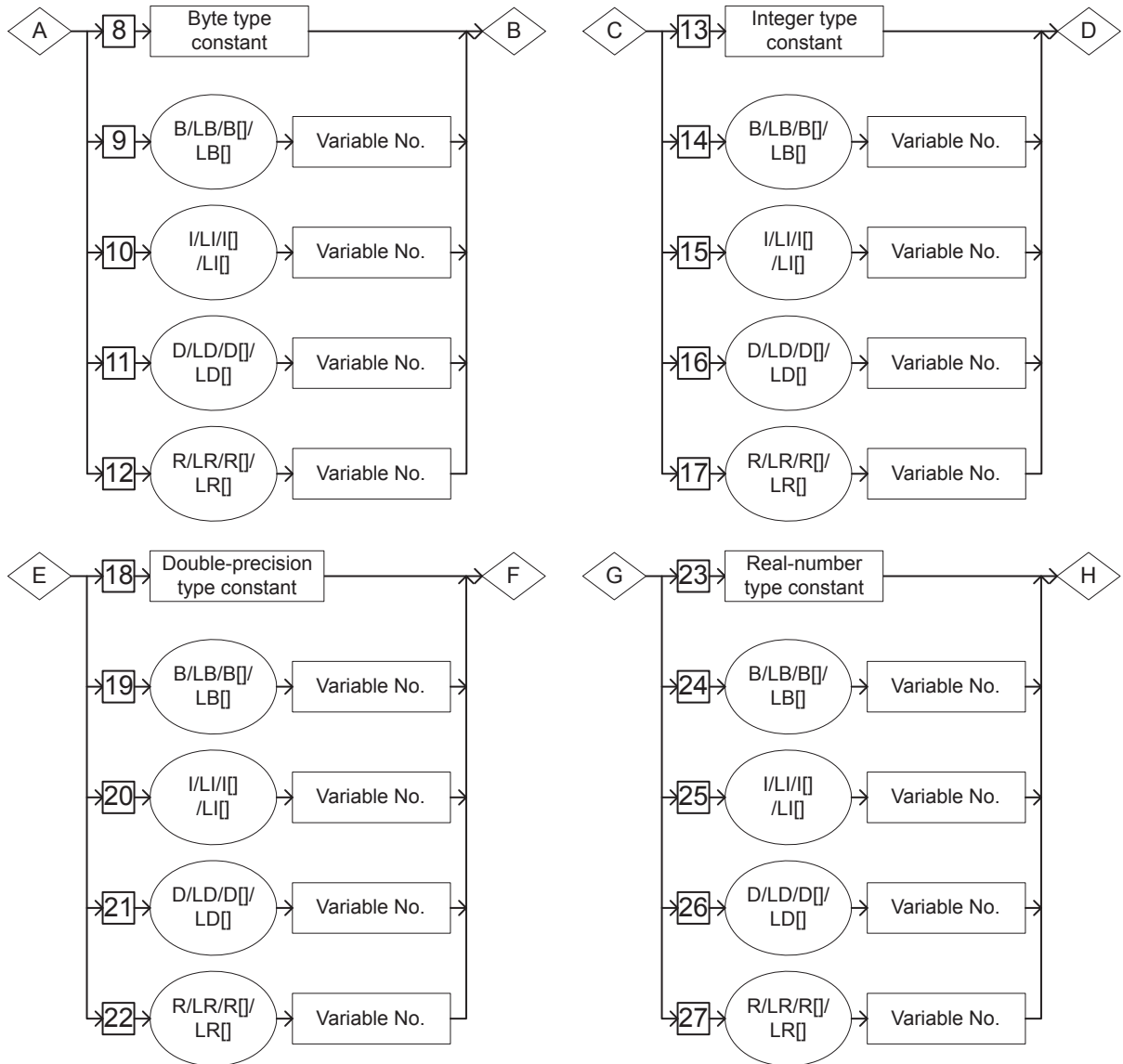

2.3 Operating Instruction

Explanation

1. B Variable number/LB Variable number/B [Array number]/LB [Array number]/I Variable number/LI Variable number/I [Array number]/LI [Array number]/D Variable number/LD Variable number/D [Array number]/LD [Array number]/R Variable number/LR Variable number/R [Array number]/LR [Array number]/P Variable number/LP Variable number/P [Array number]/LP [Array number]/BP Variable number/LBP Variable number/BP [Array number]/LBP [Array number]/EX Variable number/LEX Variable number/EX [Array number]/LEX [Array number]

Choose one of the tags from the following table.

No.	Tag	Explanation	Note
1	B Variable number/ LB Variable number/ B [Array number]/ LB [Array number]	Specifies the number of the byte type variable to be added.	<Data 1>
2	I Variable number/ LI Variable number/ I [Array number]/ LI [Array number]	Specifies the number of the integer type variable to be added.	<Data 1>
3	D Variable number/ LD Variable number/ D [Array number]/ LD [Array number]	Specifies the number of the double-precision type variable to be added.	<Data 1>
4	R Variable number/ LR Variable number/ R [Array number]/ LR [Array number]	Specifies the number of the real-number type variable to be added.	<Data 1>
5	P Variable number/ LP Variable number/ P [Array number]/ LP [Array number]	Specifies the number of the robot axis position type variable to be added.	<Data 1>
6	BP Variable number/ LBP Variable number/ BP [Array number]/ LBP [Array number]	Specifies the number of the base axis position type variable to be added.	<Data 1>
7	EX Variable number/ LEX Variable number/ EX [Array number]/ LEX [Array number]	Specifies the number of the station axis position type variable to be added.	<Data 1>

2.3 Operating Instruction

2. Byte type constant/B Variable number/LB Variable number/B [Array number]/LB [Array number]/I Variable number/LI Variable number/I [Array number]/LI [Array number]/D Variable number/LD Variable number/D [Array number]/LD [Array number]/R Variable number/LR Variable number/R [Array number]/LR [Array number]

When a B Variable number, LB Variable number, B [Array number], or LB [Array number] is selected from the table in part 1 of this Explanation, choose one of the tags from the following table.

No.	Tag	Explanation	Note
8	Byte type constant	Specifies the byte type data to be added.	<Data 2>
9	B Variable number/ LB Variable number/ B [Array number]/ LB [Array number]	Specifies the number of the byte type variable to be added.	<Data 2>
10	I Variable number/LI Variable number/ I [Array number]/ LI [Array number]	Specifies the number of the integer type variable to be added.	<Data 2>
11	D Variable number/ LD Variable number/ D [Array number]/ LD [Array number]	Specifies the number of the double-precision type variable to be added.	<Data 2>
12	R Variable number/ LR Variable number/ R [Array number]/ LR [Array number]	Specifies the number of the real-number type variable to be added.	<Data 2>

3. Integer type constant/B Variable number/LB Variable number/B [Array number]/LB [Array number]/I Variable number/LI Variable number/I [Array number]/LI [Array number]/D Variable number/LD Variable number/D [Array number]/LD [Array number]/R Variable number/LR Variable number/R [Array number]/LR [Array number]

When an I Variable number, LI Variable number, I [Array number], or LI [Array number] is selected from the table in part 1 of this Explanation, choose one of the tags from the following table.

No.	Tag	Explanation	Note
13	Integer type constant	Specifies the integer type data to be added.	<Data 2>
14	B Variable number/ LB Variable number/ B [Array number]/ LB [Array number]	Specifies the number of the byte-type variable to be added.	<Data 2>

2.3 Operating Instruction

No.	Tag	Explanation	Note
15	I Variable number/LI Variable number/ I [Array number]/ LI [Array number]	Specifies the number of the integer type variable to be added.	<Data 2>
16	D Variable number/ LD Variable number/ D [Array number]/ LD [Array number]	Specifies the number of the double-precision type variable to be added.	<Data 2>
17	R Variable number/ LR Variable number/ R [Array number]/ LR [Array number]	Specifies the number of the real-number type variable to be added.	<Data 2>

4. Double-precision type constant/B Variable number/
LB Variable number/B [Array number]/LB [Array
number]/I Variable number/LI Variable number/I
[Array number]/LI [Array number]/D Variable
number/LD Variable number/D [Array number]/LD
[Array number]/R Variable number/LR Variable
number/R [Array number]/LR [Array number]

When a D Variable number, LD Variable number, D [Array number], or LD [Array number] is selected from the table in part 1 of this Explanation, choose one of the tags from the following table.

No.	Tag	Explanation	Note
18	Double-precision type constant	Specifies the double-precision type data to be added.	<Data 2>
19	B Variable number/ LB Variable number/ B [Array number]/ LB [Array number]	Specifies the number of the byte type variable to be added.	<Data 2>
20	I Variable number/LI Variable number/ I [Array number]/ LI [Array number]	Specifies the number of the integer type variable to be added.	<Data 2>
21	D Variable number/ LD Variable number/ D [Array number]/ LD [Array number]	Specifies the number of the double-precision type variable to be added.	<Data 2>
22	R Variable number/ LR Variable number/ R [Array number]/ LR [Array number]	Specifies the number of the real-number type variable to be added.	<Data 2>

2.3 Operating Instruction

5. Real-number type constant/B Variable number/LB Variable number/B [Array number]/LB [Array number]/I Variable number/LI Variable number/I [Array number]/LI [Array number]/D Variable number/LD Variable number/D [Array number]/LD [Array number]/R Variable number/LR Variable number/R [Array number]/LR [Array number]

When an R Variable number, LR Variable number, R [Array number], or LR [Array number] is selected from the table in part 1 of this Explanation, choose one of the tags from the following table.

No.	Tag	Explanation	Note
23	Real-number type constant	Specifies the real-number type data to be added.	<Data 2>
24	B Variable number/ LB Variable number/ B [Array number]/ LB [Array number]	Specifies the number of the byte type variable to be added.	<Data 2>
25	I Variable number/LI Variable number/ I [Array number]/ LI [Array number]	Specifies the number of the integer type variable to be added.	<Data 2>
26	D Variable number/ LD Variable number/ D [Array number]/ LD [Array number]	Specifies the number of the double-precision type variable to be added.	<Data 2>
27	R Variable number/ LR Variable number/ R [Array number]/ LR [Array number]	Specifies the number of the real-number type variable to be added.	<Data 2>

6. P Variable number/LP Variable number/P [Array number]/LP [Array number]

When a P Variable number, LP Variable number, P [Array number], or LP [Array number] is selected from the table in part 1 of this Explanation, add the following tag.

No.	Tag	Explanation	Note
28	P Variable number/ LP Variable number/ P [Array number]/ LP [Array number]	Specifies the number of the robot axis position type variable to be added.	<Data 2>

2.3 Operating Instruction

7. BP Variable number/LBP Variable number/BP [Array number]/LBP [Array number]

When a BP Variable number, LBP Variable number, BP [Array number], or LBP [Array number] is selected from the table in part 1 of this Explanation, add the following tag.

No.	Tag	Explanation	Note
29	BP Variable number/ LBP Variable number/ BP [Array number]/ LBP [Array number]	Specifies the number of the base axis position type variable to be added.	<Data 2>

8. EX Variable number/LEX Variable number/EX [Array number]/LEX [Array number]

When an EX Variable number, LEX Variable number, EX [Array number], or LEX [Array number] is selected from the table in part 1 of this Explanation, add the following tag.

No	Tag	Explanation	Note
30	EX Variable number/ LEX Variable number/ EX [Array number]/ LEX [Array number]	Specifies the number of the station axis position type variable to be added.	<Data 2>

Example

- (1) ADD B000 10
Adds 10 to B000, and stores the result in B000.
- (2) ADD I000 I001
Adds I001 to I000, and stores the result in I000.
- (3) ADD P000 P001
Adds P001 to P000, and stores the result in P000.

SUB

SUBSET	STANDARD	EXPANDED
Not available	Available	Available

Function

Subtracts Data 2 from Data 1, and stores the result in Data 1.

Construction

SUB <Data 1> <Data 2>

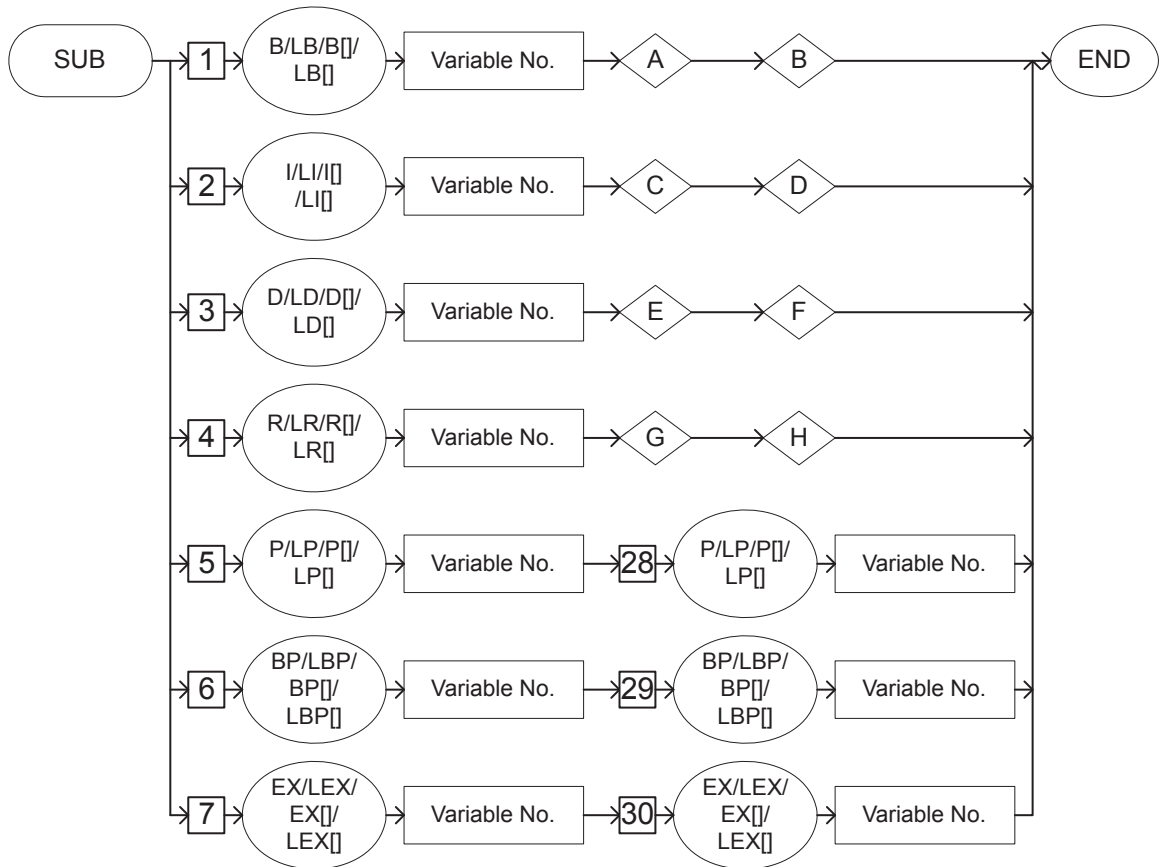

2.3 Operating Instruction

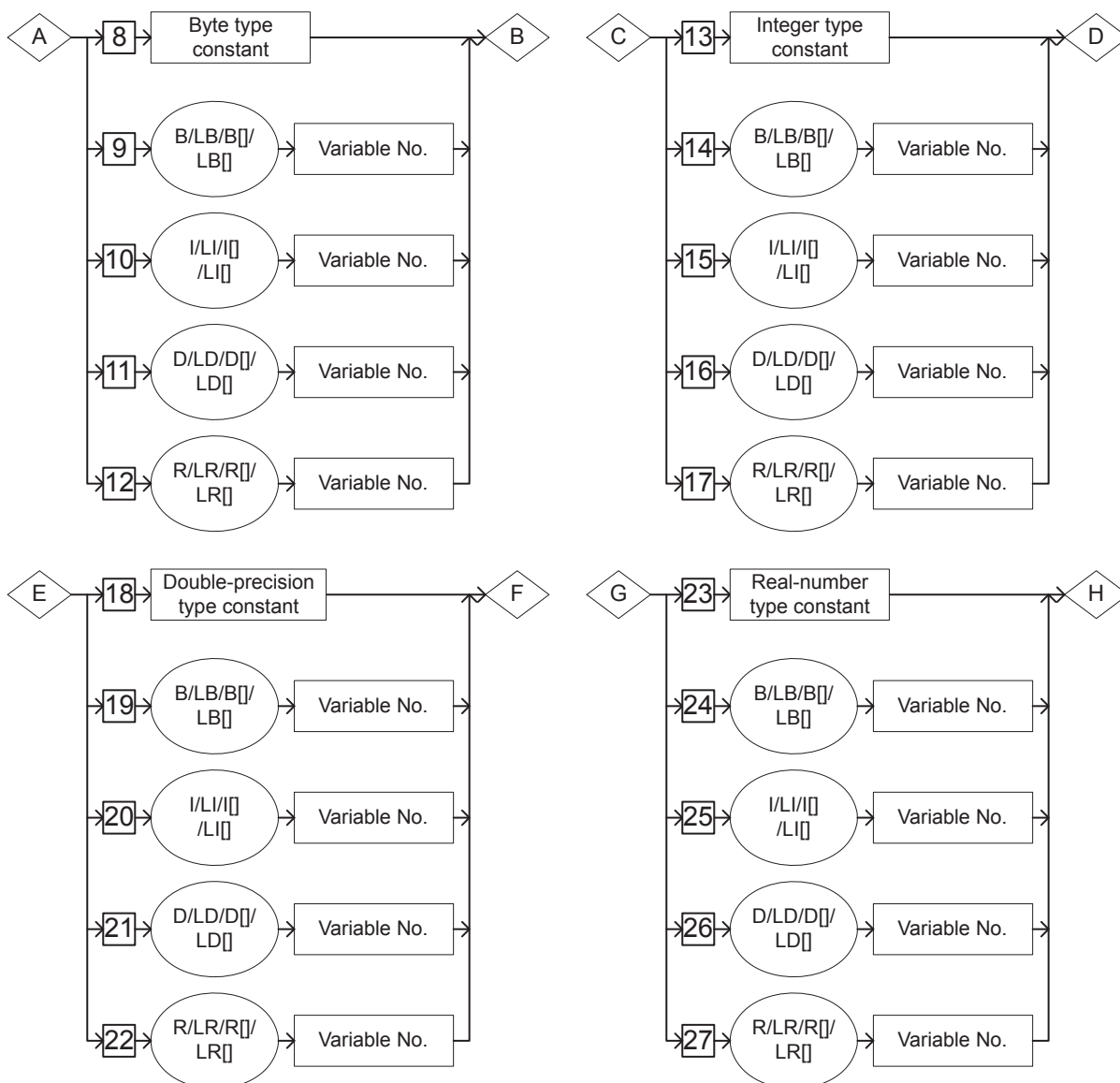

2.3 Operating Instruction

Explanation

1. B Variable number/LB Variable number/B [Array number]/LB [Array number]/I Variable number/LI Variable number/I [Array number]/LI [Array number]/D Variable number/LD Variable number/D [Array number]/LD [Array number]/R Variable number/LR Variable number/R [Array number]/LR [Array number]/P Variable number/LP Variable number/P [Array number]/LP [Array number]/BP Variable number/LBP Variable number/BP [Array number]/LBP [Array number]/EX Variable number/LEX Variable number/EX [Array number]/LEX [Array number]

Choose one of the tags from the following table.

No.	Tag	Explanation	Note
1	B Variable number/ LB Variable number/ B [Array number]/ LB [Array number]	Specifies the number of the byte type variable to be subtracted.	<Data 1>
2	I Variable number/ LI Variable number/ I [Array number]/ LI [Array number]	Specifies the number of the integer type variable to be subtracted.	<Data 1>
3	D Variable number/ LD Variable number/ D [Array number]/ LD [Array number]	Specifies the number of the double-precision type variable to be subtracted.	<Data 1>
4	R Variable number/ LR Variable number/ R [Array number]/ LR [Array number]	Specifies the number of the real-number type variable to be subtracted.	<Data 1>
5	P Variable number/ LP Variable number/ P [Array number]/ LP [Array number]	Specifies the number of the robot axis position type variable to be subtracted.	<Data 1>
6	BP Variable number/ LBP Variable number/ BP [Array number]/ LBP [Array number]	Specifies the number of the base axis position type variable to be subtracted.	<Data 1>
7	EX Variable number/ LEX Variable number/ EX [Array number]/ LEX [Array number]	Specifies the number of the station axis position type variable to be subtracted.	<Data 1>

2.3 Operating Instruction

2. Byte type constant/B Variable number/LB Variable number/B [Array number]/LB [Array number]/I Variable number/LI Variable number/I [Array number]/LI [Array number]/D Variable number/LD Variable number/D [Array number]/LD [Array number]/R Variable number/LR Variable number/R [Array number]/LR [Array number]

When a B Variable number, LB Variable number, B [Array number], or LB [Array number] is selected from the table in part 1 of this Explanation, choose one of the tags from the following table.

No.	Tag	Explanation	Note
8	Byte type constant	Specifies the byte type data to be subtracted.	<Data 2>
9	B Variable number/ LB Variable number/ B [Array number]/ LB [Array number]	Specifies the number of the byte type variable to be subtracted.	<Data 2>
10	I Variable number/ LI Variable number/ I [Array number]/ LI [Array number]	Specifies the number of the integer type variable to be subtracted.	<Data 2>
11	D Variable number/ LD Variable number/ D [Array number]/ LD [Array number]	Specifies the number of the double-precision type variable to be subtracted.	<Data 2>
12	R Variable number/ LR Variable number/ R [Array number]/ LR [Array number]	Specifies the number of the real-number type variable to be subtracted.	<Data 2>

3. Integer type constant/B Variable number/LB Variable number/B [Array number]/LB [Array number]/I Variable number/LI Variable number/I [Array number]/LI [Array number]/D Variable number/LD Variable number/D [Array number]/LD [Array number]/R Variable number/LR Variable number/R [Array number]/LR [Array number]

When an I Variable number, LI Variable number, I [Array number], or LI [Array number] is selected from the table part 1 of this Explanation, choose one of the tags from the following table.

No.	Tag	Explanation	Note
13	Integer type constant	Specifies the integer type data to be subtracted.	<Data 2>
14	B Variable number/ LB Variable number/ B [Array number]/ LB [Array number]	Specifies the number of the byte type variable to be subtracted.	<Data 2>

2.3 Operating Instruction

No.	Tag	Explanation	Note
15	I Variable number/ LI Variable number/ I [Array number]/ LI [Array number]	Specifies the number of the integer type variable to be subtracted.	<Data 2>
16	D Variable number/ LD Variable number/ D [Array number]/ LD [Array number]	Specifies the number of the double-precision type variable to be subtracted.	<Data 2>
17	R Variable number/ LR Variable number/ R [Array number]/ LR [Array number]	Specifies the number of the real-number type variable to be subtracted.	<Data 2>

4. Double-precision type constant/B Variable number/
LB Variable number/B [Array number]/LB [Array
number]/I Variable number/LI Variable number/I
[Array number]/LI [Array number]/D Variable
number/LD Variable number/D [Array number]/LD
[Array number]/R Variable number/LR Variable
number/R [Array number]/LR [Array number]

When a D Variable number, LD Variable number, D [Array number], or LD [Array number] is selected from the table in part 1 of this Explanation, choose one of the tags from the following table.

No.	Tag	Explanation	Note
18	Double-precision type constant	Specifies the double-precision type data to be subtracted.	<Data 2>
19	B Variable number/ LB Variable number/ B [Array number]/ LB [Array number]	Specifies the number of the byte type variable to be subtracted.	<Data 2>
20	I Variable number/ LI Variable number/ I [Array number]/ LI [Array number]	Specifies the number of the integer type variable to be subtracted.	<Data 2>
21	D Variable number/ LD Variable number/ D [Array number]/ LD [Array number]	Specifies the number of the double-precision type variable to be subtracted.	<Data 2>
22	R Variable number/ LR Variable number/ R [Array number]/ LR [Array number]	Specifies the number of the real-number type variable to be subtracted.	<Data 2>

2.3 Operating Instruction

5. Real-number type constant/B Variable number/LB Variable number/B [Array number]/LB [Array number]/I Variable number/LI Variable number/I [Array number]/LI [Array number]/D Variable number/LD Variable number/D [Array number]/LD [Array number]/R Variable number/LR Variable number/R [Array number]/LR [Array number]

When an R Variable number, LR Variable number, R [Array number], or LR [Array number] is selected from the table in part 1 of this Explanation, choose one of the tags from the following table.

No.	Tag	Explanation	Note
23	Real-number type constant	Specifies the real-number type data to be subtracted.	<Data 2>
24	B Variable number/ LB Variable number/ B [Array number]/ LB [Array number]	Specifies the number of the byte type variable to be subtracted.	<Data 2>
25	I Variable number/ LI Variable number/ I [Array number]/ LI [Array number]	Specifies the number of the integer type variable to be subtracted.	<Data 2>
26	D Variable number/ LD Variable number/ D [Array number]/ LD [Array number]	Specifies the number of the double-precision type variable to be subtracted.	<Data 2>
27	R Variable number/ LR Variable number/ R [Array number]/ LR [Array number]	Specifies the number of the real-number type variable to be subtracted.	<Data 2>

6. P Variable number/LP Variable number/P [Array number]/LP [Array number]

When a P Variable number, LP Variable number, P [Array number], or LP [Array number] is selected from the table in part 1 of this Explanation, add the following tag.

No.	Tag	Explanation	Note
28	P Variable number/ LP Variable number/ P [Array number]/ LP [Array number]	Specifies the number of the robot axis position type variable to be subtracted.	<Data 2>

2.3 Operating Instruction

7. BP Variable number/LBP Variable number/BP [Array number]/LBP [Array number]

When a BP Variable number, LBP Variable number, BP [Array number], or LBP [Array number] is selected from the table in part 1 of this Explanation, add the following tag.

No.	Tag	Explanation	Note
29	BP Variable number/ LBP Variable number/ BP [Array number]/ LBP [Array number]	Specifies the number of the base axis position type variable to be subtracted.	<Data 2>

8. EX Variable number/LEX Variable number/EX [Array number]/LEX [Array number]

When an EX Variable number, LEX Variable number, EX [Array number], or LEX [Array number] is selected from the table in part 1 of this Explanation, add the following tag.

No.	Tag	Explanation	Note
30	EX Variable number/ LEX Variable number/ EX [Array number]/ LEX [Array number]	Specifies the number of the station axis position type variable to be subtracted.	<Data 2>

Example

- (1) SUB B000 10
Subtracts 10 from B000, and stores the result in B000.
- (2) SUB I000 I001
Subtracts I001 from I000, and stores the result in I000.
- (3) SUB P000 P001
Subtracts P001 from P000, and stores the result in P000.

MUL

SUBSET	STANDARD	EXPANDED
Not available	Available	Available

Function

Multiplies Data 1 by Data 2, and stores the result in Data 1.

Construction

MUL <Data 1> <Data 2>

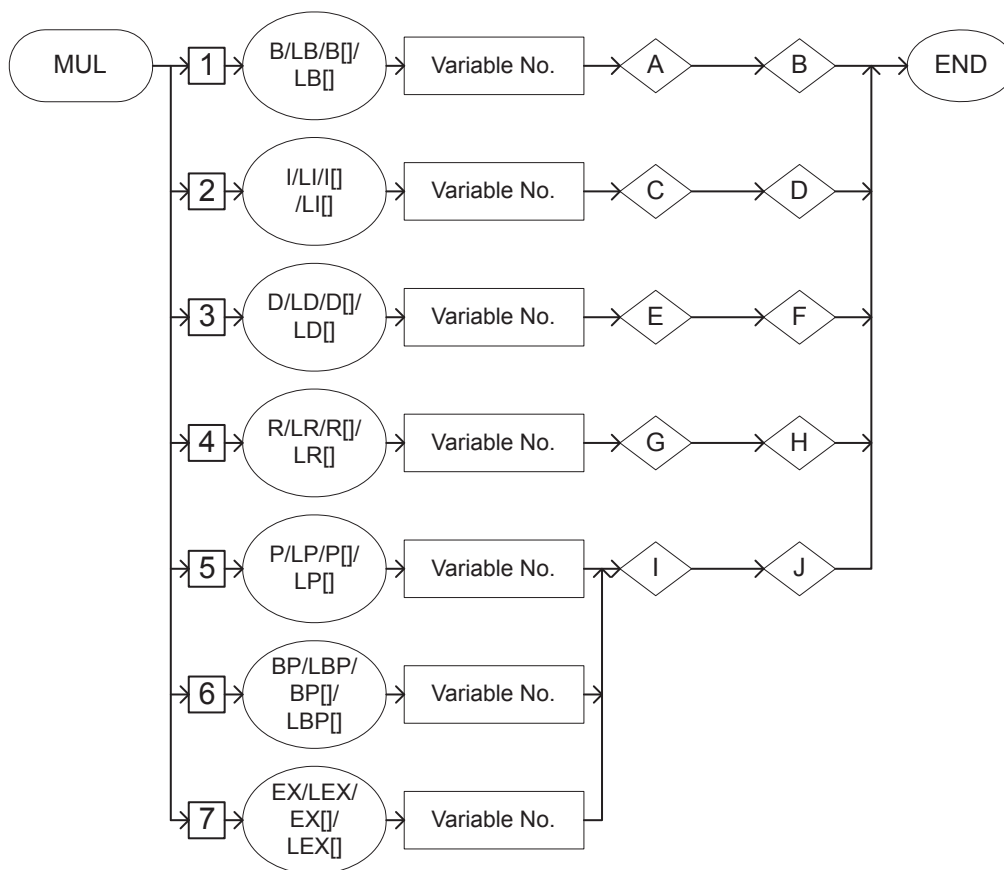

2.3 Operating Instruction

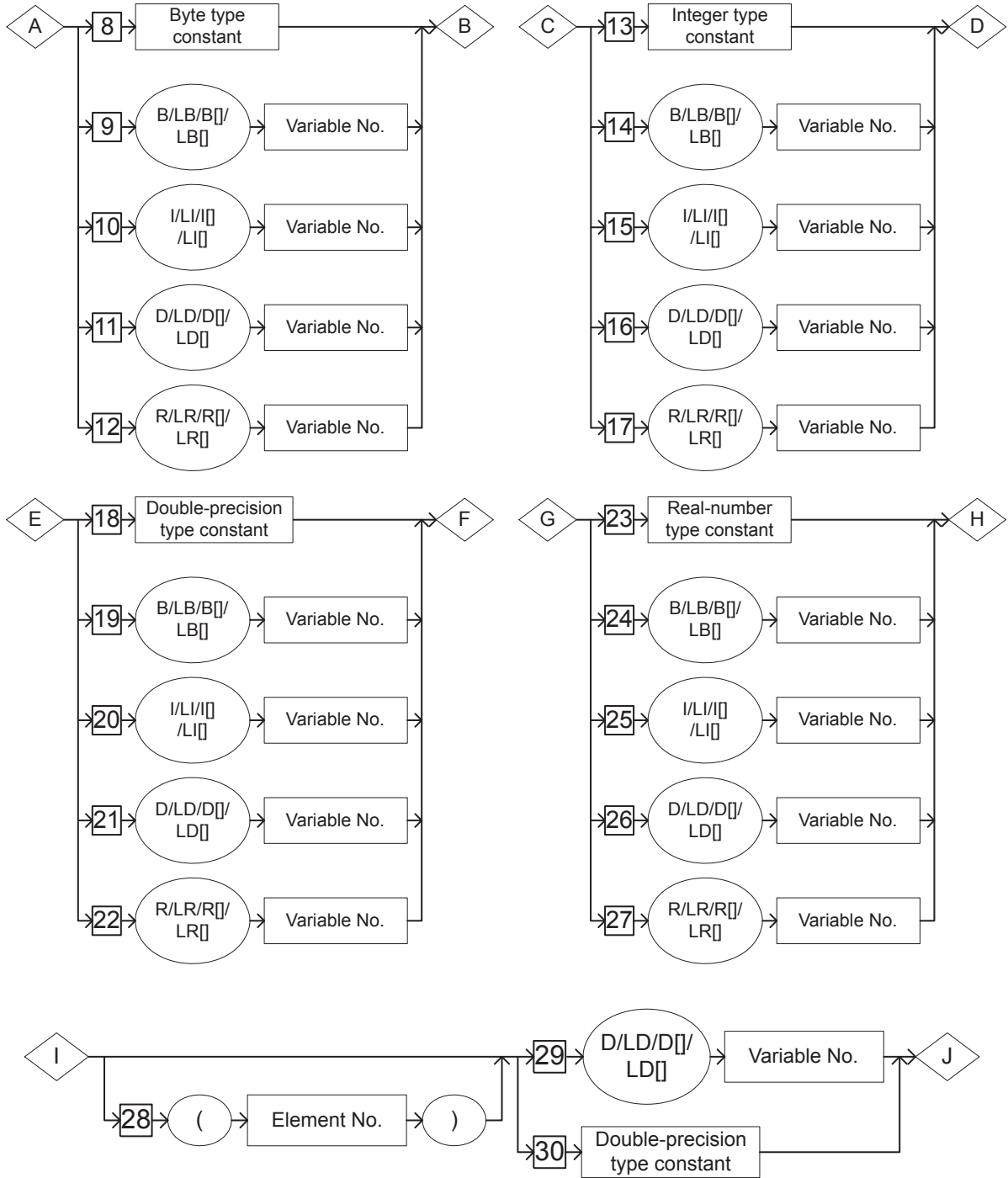

2.3 Operating Instruction

Explanation

1. B Variable number/LB Variable number/B [Array number]/LB [Array number]/I Variable number/LI Variable number/I [Array number]/LI [Array number]/D Variable number/LD Variable number/D [Array number]/LD [Array number]/R Variable number/LR Variable number/R [Array number]/LR [Array number]/P Variable number/LP Variable number/P [Array number]/LP [Array number]/BP Variable number/LBP Variable number/BP [Array number]/LBP [Array number]/EX Variable number/LEX Variable number/EX [Array number]/LEX [Array number]

Choose one of the tags from the following table.

No.	Tag	Explanation	Note
1	B Variable number/ LB Variable number B [Array number]/ LB [Array number]	Specifies the number of the byte type variable to be multiplied.	<Data 1>
2	I Variable number/ LI Variable number/ I [Array number]/ LI [Array number]	Specifies the number of the integer type variable to be multiplied.	<Data 1>
3	D Variable number/ LD Variable number/ D [Array number]/ LD [Array number]	Specifies the number of the double-precision type variable to be multiplied.	<Data 1>
4	R Variable number/ LR Variable number/ R [Array number]/ LR [Array number]	Specifies the number of the real-number type variable to be multiplied.	<Data 1>
5	P Variable number/ LP Variable number/ P [Array number]/ LP [Array number]	Specifies the number of the robot axis position type variable to be multiplied.	<Data 1>
6	BP Variable number/ LBP Variable number/ BP [Array number]/ LBP [Array number]	Specifies the number of the base axis position type variable to be multiplied.	<Data 1>
7	EX Variable number/ LEX Variable number/ EX [Array number]/ LEX [Array number]	Specifies the number of the station axis position type variable to be multiplied.	<Data 1>

2.3 Operating Instruction

2. Byte type constant/B Variable number/LB Variable number/B [Array number]/LB [Array number]/I Variable number/LI Variable number/I [Array number]/LI [Array number]/D Variable number/LD Variable number/D [Array number]/LD [Array number]/R Variable number/LR Variable number/R [Array number]/LR [Array number]

When a B Variable number, LB Variable number, B [Array number], or LB [Array number] is selected from the table in part 1 of this Explanation, choose one of the tags from the following table.

No.	Tag	Explanation	Note
8	Byte type constant	Specifies the byte type data to be multiplied.	<Data 2>
9	B Variable number/ LB Variable number/ B [Array number]/ LB [Array number]	Specifies the number of the byte type variable to be multiplied.	<Data 2>
10	I Variable number/ LI Variable number/ I [Array number]/ LI [Array number]	Specifies the number of the integer type variable to be multiplied	<Data 2>
11	D Variable number/ LD Variable number/ D [Array number]/ LD [Array number]	Specifies the number of the double-precision type variable to be multiplied.	<Data 2>
12	R Variable number/ LR Variable number/ R [Array number]/ LR [Array number]	Specifies the number of the real-number type variable to be multiplied.	<Data 2>

3. Integer type constant/B Variable number/LB Variable number/B [Array number]/LB [Array number]/I Variable number/LI Variable number/I [Array number]/LI [Array number]/D Variable number/LD Variable number/D [Array number]/LD [Array number]/R Variable number/LR Variable number/R [Array number]/LR [Array number]

2.3 Operating Instruction

When an I Variable number, LI Variable number, I [Array number], or LI [Array number] is selected from the table in part 1 of this Explanation, choose one of the tags from the following table.

No.	Tag	Explanation	Note
13	Integer type constant	Specifies the integer type data to be multiplied.	<Data 2>
14	B Variable number/ LB Variable number/ B [Array number]/ LB [Array number]	Specifies the number of the byte type variable to be multiplied.	<Data 2>
15	I Variable number/ LI Variable number/ I [Array number]/ LI [Array number]	Specifies the number of the integer type variable to be multiplied.	<Data 2>
16	D Variable number/ LD Variable number/ D [Array number]/ LD [Array number]	Specifies the number of the double-precision type variable to be multiplied.	<Data 2>
17	R Variable number/ LR Variable number/ R [Array number]/ LR [Array number]	Specifies the number of the real-number type variable to be multiplied.	<Data 2>

4. Double-precision type constant/B Variable number/LB Variable number/B [Array number]/LB [Array number]/I Variable number/LI Variable number/I [Array number]/LI [Array number]/D Variable number/LD Variable number/D [Array number]/LD [Array number]/R Variable number/LR Variable number/R [Array number]/LR [Array number]

When a D Variable number, LD Variable number, D [Array number], or LD [Array number] is selected from the table in part 1 of this Explanation, choose one of the tags from the following table.

No.	Tag	Explanation	Note
18	Double-precision type constant	Specifies the double-precision type data to be multiplied.	<Data 2>
19	B Variable number/ LB Variable number/ B [Array number]/ LB [Array number]	Specifies the number of the byte type variable to be multiplied.	<Data 2>
20	I Variable number/ LI Variable number/ I [Array number]/ LI [Array number]	Specifies the number of the integer type variable to be multiplied.	<Data 2>
21	D Variable number/ LD Variable number/ D [Array number]/ LD [Array number]	Specifies the number of the double-precision type variable to be multiplied.	<Data 2>
22	R Variable number/ LR Variable number/ R [Array number]/ LR [Array number]	Specifies the number of the real-number type variable to be multiplied.	<Data 2>

2.3 Operating Instruction

5. Real-number type constant/B Variable number/LB Variable number/B [Array number]/LB [Array number]/I Variable number/LI Variable number/I [Array number]/LI [Array number]/D Variable number/LD Variable number/D [Array number]/LD [Array number]/R Variable number/LR Variable number/R [Array number]/LR [Array number]

When an R Variable number, LR Variable number, R [Array number], or LR [Array number] is selected from the table in part 1 of this Explanation, choose one of the tags from the following table.

No.	Tag	Explanation	Note
23	Real-number type constant	Specifies the real-number type data to be multiplied.	<Data 2>
24	B Variable number/ LB Variable number/ B [Array number]/ LB [Array number]	Specifies the number of the byte type variable to be multiplied.	<Data 2>
25	I Variable number/ LI Variable number/ I [Array number]/ LI [Array number]	Specifies the number of the integer type variable to be multiplied.	<Data 2>
26	D Variable number/ LD Variable number/ D [Array number]/ LD [Array number]	Specifies the number of the double-precision type variable to be multiplied.	<Data 2>
27	R Variable number/ LR Variable number/ R [Array number]/ LR [Array number]	Specifies the number of the real-number type variable to be multiplied.	<Data 2>

6. (Element number)

When a P Variable number, LP Variable number, P [Array number], LP [Array number], BP Variable number, LBP Variable number, BP [Array number], LBP [Array number], EX Variable number, LEX Variable number, EX [Array number], or LEX [Array number] is selected from the table in part 1 of this Explanation, the following tag can be added or omitted.

No.	Tag	Explanation	Note
28	(Element number)	Specifies the element of the position type variable to be multiplied. If omitted, all the elements of the position type variable are specified.	Element number: 1 to 255 Variable B/LB can be used.



Element of position type variable

The element of position type variable differs depending on the type of variable as follows.

- Robot axis position type variable

<Pulse type>

(1): 1st axis data, (2): 2nd axis data, (3): 3rd axis data, (4) 4th axis data, (5): 5th axis data, (6) 6th axis data, (7): 7th axis data, (8): 8th axis data

<XYZ type>

(1): X axis data, (2): Y axis data, (3) Z axis data,
(4): Rx axis data
(5): Ry axis data, (6): Rz axis data, (7): Re axis data

- Base axis position type variable

(1): 1st axis data, (2): 2nd axis data ♦♦♦

- Station axis position type variable

(1): 1st axis data, (2): 2nd axis data ♦♦♦

7. D Variable number/LD Variable number/D [Array number]/LD [Array number]/ Double-precision type constant

When a P Variable number, LP Variable number, P [Array number], LP [Array number], BP Variable number, LBP Variable number, BP [Array number], LBP [Array number], EX Variable number, LEX Variable number, EX [Array number], or LEX [Array number] is selected from the table in part 1 of this Explanation, choose one of the tags from the following table after (Element number) of 6.

No.	Tag	Explanation	Note
29	D Variable number/ LD Variable number/ D [Array number]/ LD [Array number]	Specifies the number of the double-precision variable by which the element of position type variable is multiplied.	<Data 2>
30	Double-precision type constant	Specifies the double-precision type data by which the element of position type variable is multiplied.	<Data 2>

Example

- (1) MUL B000 10
Multiplies B000 by 10, and stores the result in B000.
- (2) MUL I000 I001
Multiplies I000 by I001, and stores the result in I000.
- (3) SET D000 2
MUL P000 (3) D000
Multiplies the Z axis data of P000 by D000 (D000=2), and stores the result in P000.

DIV

SUBSET	STANDARD	EXPANDED
Not available	Available	Available

Function

Divides Data 1 by Data 2, and stores the result in Data 1.

Construction

DIV <Data 1> <Data 2>

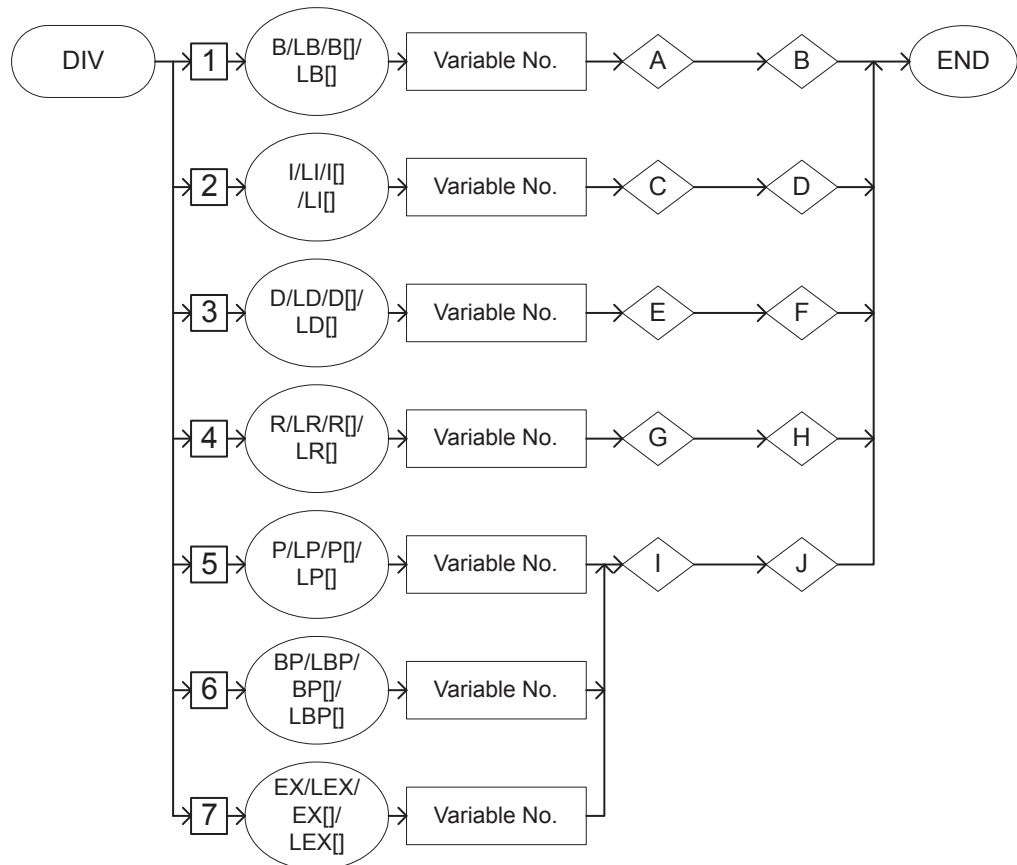

2.3 Operating Instruction

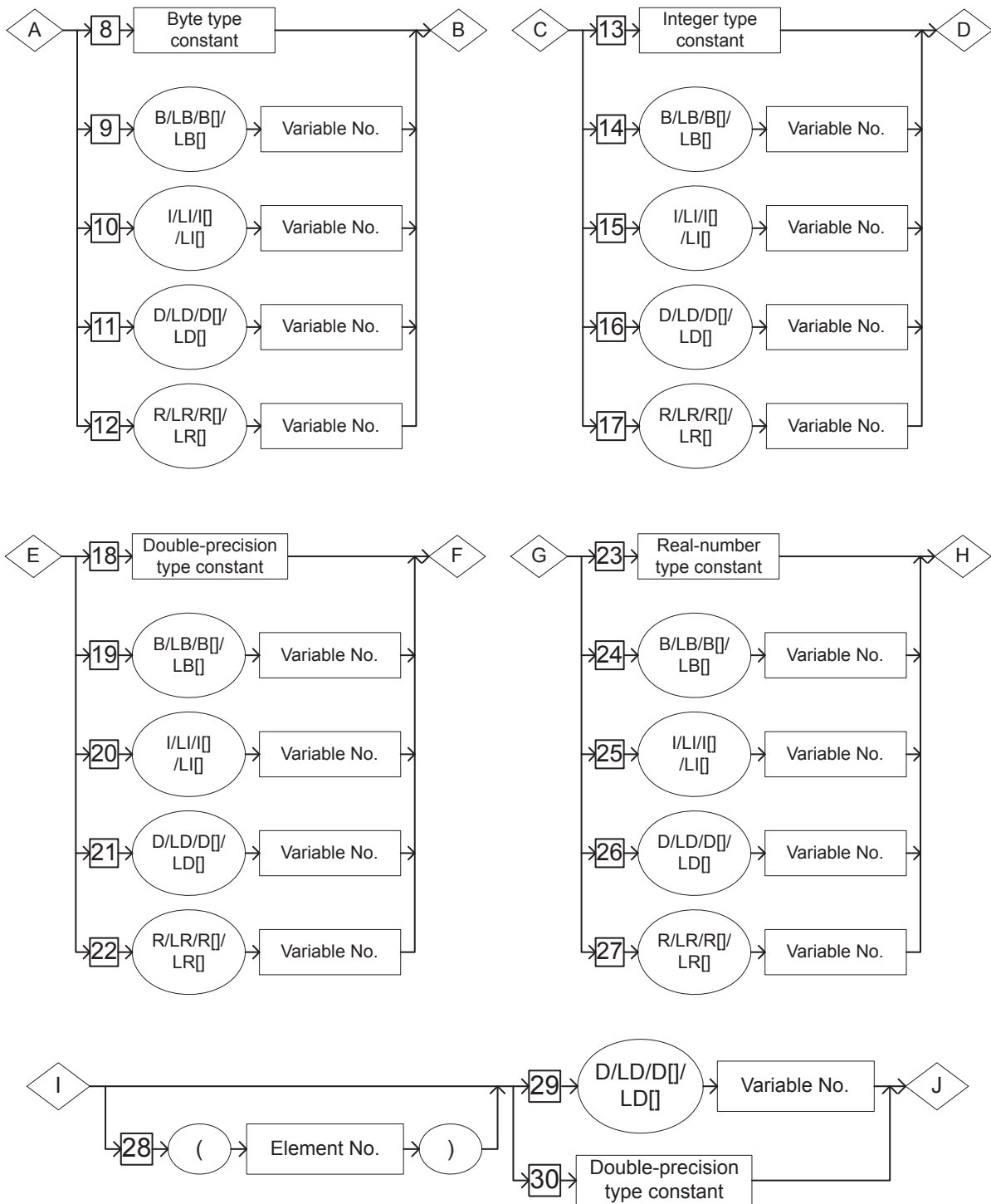

2.3 Operating Instruction

Explanation

1. B Variable number/LB Variable number/B [Array number]/LB [Array number]/I Variable number/LI [Array number]/I [Array number]/LI [Array number]/D Variable number/LD Variable number/D [Array number]/LD [Array number]/R Variable number/LR Variable number/R [Array number]/LR [Array number]/P Variable number/LP Variable number/P [Array number]/LP [Array number]/BP Variable number/LBP Variable number/BP [Array number]/LBP [Array number]/EX Variable number/LEX Variable number/EX [Array number]/LEX [Array number]

Choose one of the tags from the following table.

No.	Tag	Explanation	Note
1	B Variable number/ LB Variable number/ B [Array number]/ LB [Array number]	Specifies the number of the byte type variable to be divided.	<Data 1>
2	I Variable number/ LI Variable number/ I [Array number]/ LI [Array number]	Specifies the number of the integer type variable to be divided.	<Data 1>
3	D Variable number/ LD Variable number/ D [Array number]/ LD [Array number]	Specifies the number of the double-precision type variable to be divided.	<Data 1>
4	R Variable number/ LR Variable number/ R [Array number]/ LR [Array number]	Specifies the number of the real-number type variable to be divided.	<Data 1>
5	P Variable number/ LP Variable number/ P [Array number]/ LP [Array number]	Specifies the number of the robot axis position type variable to be divided.	<Data 1>
6	BP Variable number/ LBP Variable number/ BP [Array number]/ LBP [Array number]	Specifies the number of the base axis position type variable to be divided.	<Data 1>
7	EX Variable number/ LEX Variable number/ EX [Array number]/ LEX [Array number]	Specifies the number of the station axis position type variable to be divided.	<Data 1>

2.3 Operating Instruction

2. Byte type constant/B Variable number/LB Variable number/B [Array number]/LB [Array number]/I Variable number/LI Variable number/I [Array number]/LI [Array number]/D Variable number/LD Variable number/D [Array number]/LD [Array number]/R Variable number/LR Variable number/R [Array number]/LR [Array number]

When a B Variable number, LB Variable number, B [Array number], or LB [Array number] is selected from the table in part 1 of this explanation, choose one of the tags from the following table.

No.	Tag	Explanation	Note
8	Byte type constant	Specifies the byte type data by which Data 1 is divided.	<Data 2>
9	B Variable number/ LB Variable number/ B [Array number]/ LB [Array number]	Specifies the number of the byte type variable by which Data 1 is divided.	<Data 2>
10	I Variable number/ LI Variable number/ I [Array number]/ LI [Array number]	Specifies the number of the integer type variable by which Data 1 is divided.	<Data 2>
11	D Variable number/ LD Variable number/ D [Array number]/ LD [Array number]	Specifies the number of the double-precision type variable by which Data 1 is divided.	<Data 2>
12	R Variable number/ LR Variable number/ R [Array number]/ LR [Array number]	Specifies the number of the real-number type variable by which Data 1 is divided.	<Data 2>

3. Integer type constant/B Variable number/LB Variable number/B [Array number]/LB [Array number]/I Variable number/LI Variable number/I [Array number]/LI [Array number]/D Variable number/LD Variable number/D [Array number]/LD [Array number]/R Variable number/LR Variable number/R [Array number]/LR [Array number]

When an I Variable number, LI Variable number, I [Array number], or LI [Array number] is selected from the table in part 1 of this Explanation, choose one of the tags from the following table.

No.	Tag	Explanation	Note
13	Integer type constant	Specifies the integer type data by which Data 1 is divided.	<Data 2>
14	B Variable number/ LB Variable number/ B [Array number]/ LB [Array number]	Specifies the number of the byte type variable by which Data 1 is divided.	<Data 2>

2.3 Operating Instruction

No.	Tag	Explanation	Note
15	I Variable number/ LI Variable number/ I [Array number]/ LI [Array number]	Specifies the number of the integer type variable by which Data 1 is divided.	<Data 2>
16	D Variable number/ LD Variable number/ D [Array number]/ LD [Array number]	Specifies the number of the double-precision type variable by which Data 1 is divided.	<Data 2>
17	R Variable number/ LR Variable number/ R [Array number]/ LR [Array number]	Specifies the number of the real-number type variable by which Data 1 is divided.	<Data 2>

4. Double-precision type constant/B Variable number/LB Variable number/B [Array number]/LB [Array number]/I Variable number/LI Variable number/I [Array number]/LI [Array number]/D Variable number/LD Variable number/D [Array number]/LD [Array number]/R Variable number/LR Variable number/R [Array number]/LR [Array number]

When a D Variable number, LD Variable number, D [Array number], or LD [Array number] is selected from the table in part 1 of this Explanation, choose one of the tags from the following table.

No.	Tag	Explanation	Note
18	Double-precision type constant	Specifies the double-precision type data by which Data 1 is divided.	<Data 2>
19	B Variable number/ LB Variable number/ B [Array number]/ LB [Array number]	Specifies the number of the byte type variable by which Data 1 is divided.	<Data 2>
20	I Variable number/ LI Variable number/ I [Array number]/ LI [Array number]	Specifies the number of the integer type variable by which Data 1 is divided.	<Data 2>
21	D Variable number/ LD Variable number/ D [Array number]/ LD [Array number]	Specifies the number of the double-precision type variable by which Data 1 is divided.	<Data 2>
22	R Variable number/ LR Variable number/ R [Array number]/ LR [Array number]	Specifies the number of the real-number type variable by which Data 1 is divided.	<Data 2>

5. Real-number type constant/B Variable number/LB Variable number/B [Array number]/LB [Array number]/I Variable number/LI Variable number/I [Array number]/LI [Array number]/D Variable number/LD Variable number/D [Array number]/LD [Array number]/R Variable number/LR Variable number/R [Array number]/LR [Array number]

2.3 Operating Instruction

When an R Variable number, LR Variable number, R [Array number], or LR [Array number] is selected from the table in part 1 of this Explanation, choose one of the tags from the following table.

No.	Tag	Explanation	Note
23	Real-number type constant	Specifies the real-number type data by which Data 1 is divided.	<Data 2>
24	B Variable number/ LB Variable number/ B [Array number]/ LB [Array number]	Specifies the number of the byte type variable by which Data 1 is divided.	<Data 2>
25	I Variable number/ LI Variable number/ I [Array number]/ LI [Array number]	Specifies the number of the integer type variable by which Data 1 is divided.	<Data 2>
26	D Variable number/ LD Variable number/ D [Array number]/ LD [Array number]	Specifies the number of the double-precision type variable by which Data 1 is divided.	<Data 2>
27	R Variable number/ LR Variable number/ R [Array number]/ LR [Array number]	Specifies the number of the real-number type variable by which Data 1 is divided.	<Data 2>

6. (Element number)

When a P Variable number, LP Variable number, P [Array number], LP [Array number], BP Variable number, LBP Variable number, BP [Array number], LBP [Array number], EX Variable number, LEX Variable number, EX [Array number], or LEX [Array number] is selected from the table in part 1 of this Explanation, the following tag can be added or omitted.

No.	Tag	Explanation	Note
28	(Element number)	Specifies the element of the position type variable by which Data 1 is divided. If omitted, all the elements of the position type variable are specified.	Element number: 1 to 255 Variable B/LB can be used.

7. D Variable number/LD Variable number/D [Array number]/LD [Array number]/Double-precision type constant

2.3 Operating Instruction

When a P Variable number, LP Variable number, P [Array number], LP [Array number], BP Variable number, LBP Variable number, BP [Array number], LBP [Array number], EX Variable number, LEX Variable number, EX [Array number], or LEX [Array number] is selected from the table in part 1 of this Explanation, choose one of the tags from the following table after (Element number) of 6.

No.	Tag	Explanation	Note
29	D Variable number/ LD Variable number/ D [Array number]/ LD [Array number]	Specifies the number of the double-precision variable by which the element of the position type variable is divided.	<Data 2>
30	Double-precision type constant	Specifies the double-precision type data by which the element of the position type variable is divided.	<Data 2>

Example

- (1) DIV B000 10
Divides B000 by 10, and stores the result in B000.

- (2) DIV I000 I001
Divides I000 by I001, and stores the result in I000.

- (3) SET D000 2
DIV P000 (3) D000
Divides the Z axis data by D000 (D000=2), and stores the result in P000.

CNVRT

SUBSET	STANDARD	EXPANDED
Not available	Available	Available

Function

Converts the pulse type position type variable of Data 2 to the XYZ type position type variable in the specified coordinate system, and stores the result in Data 1.

Construction

CNVRT <Data 1> <Data 2> Coordinate system designation

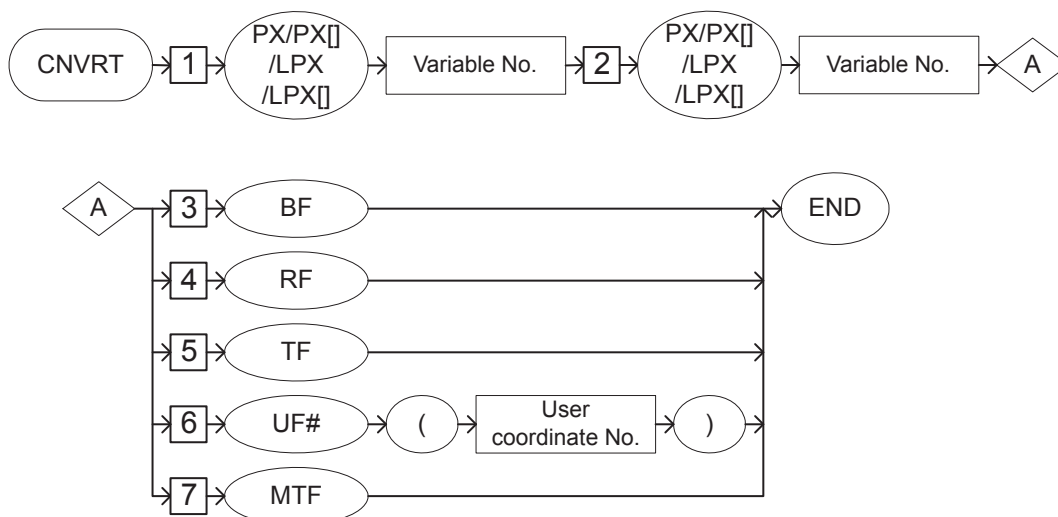

Explanation

1. PX Variable number/LPX Variable number/PX [Array number]/LPX [Array number]

Add the following tag.

No.	Tag	Explanation	Note
1	PX Variable number/ LPX Variable number/ PX [Array number]/ LPX [Array number]	Specifies the number of the expanded position type variable where the converted data is stored.	<Data 1>

2.3 Operating Instruction

**Expanded position type variables**

The expanded position type variable is a position type variable that depends on the control group in the job.

<Example>

- When the control group is R1:
PX000 indicates P000.
- When the control group is R1 + B1:
PX000 indicates P000 and BP000.
- When the control group is R1 + B1 + ST1:
PX000 indicates P000 + BP000 + EX000.
- When the control group is R1 + R2 + B1 + B2 + ST1 in the coordinated job (master R1 + B1):
PX000 indicates the following:
P000: R2 (slave), P001: R1 (master)
BP000: B2 (slave), BP001: B1 (master)
EX000: ST1

2. PX Variable number/LPX Variable number/PX [Array number]/LPX [Array number]

Add the following tag.

No.	Tag	Explanation	Note
2	PX Variable number/ LPX Variable number/ PX [Array number]/ LPX [Array number]	Specifies the number of the expanded position type variable to be converted.	<Data 2>

3. BF/RF/TF/UF# (User coordinate number)/MTF

Choose one of the tags from the following table.

No.	Tag	Explanation	Note
3	BF	Specifies the conversion in the base coordinate system.	
4	RF	Specifies the conversion in the robot coordinate system.	
5	TF	Specifies the conversion in the tool coordinate system.	
6	UF# (User coordinate number)	Specifies the conversion in the user coordinate system.	No.: 1 to 63 Variable B/I/D/LB/LI/LD can be used.
7	MTF	Specifies the conversion on the master tool coordinate system. On the master tool coordinate system, the data is converted to a position relative to the master manipulator.	Available only with the optional independent coordinate function.

2.3 Operating Instruction

Example

(1) CNVRT PX000 PX001 BF

For the job R1, the pulse type position data of P001 is converted to the XYZ type position data in the base coordinate system and stores the converted data in P000.

AND

SUBSET	STANDARD	EXPANDED
Not available	Available	Available

Function

Carries out logical multiplication of Data 1 and Data 2, and stores the result in Data 1.

Construction

AND <Data 1> <Data 2>

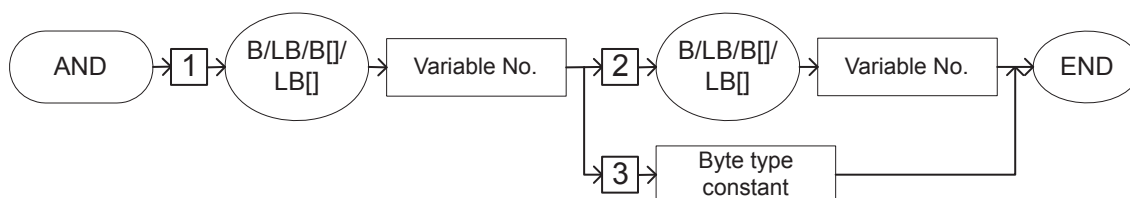

Explanation

1. B Variable number/LB Variable number/B [Array number]/LB [Array number]

Add the following tag.

No.	Tag	Explanation	Note
1	B Variable number/ LB Variable number/ B [Array number]/ LB [Array number]	Specifies the number of the byte type variable for which the logical multiplication is carried out.	<Data 1>

2. B Variable number/LB Variable number/B [Array number]/LB [Array number]/Byte type constant

Choose one of the tags from the following table.

No.	Tag	Explanation	Note
2	B Variable number/ LB Variable number/ B [Array number]/ LB [Array number]	Specifies the number of the byte type variable for which the logical multiplication is carried out.	<Data 2>
3	Byte type constant	Specifies the byte type data for which the logical multiplication is carried out.	<Data 2>

2.3 Operating Instruction

Example

- (1) SET B000 5
SET B010 1
AND B000 B010

Carries out the logical multiplication of B000 (0000 0101) and B010 (0000 0001), and stores the result (0000 0001=1) in B000.

OR

SUBSET	STANDARD	EXPANDED
Not available	Available	Available

Function

Carries out the logical sum of Data 1 and Data 2, and stores the result in Data 1.

Construction

OR <Data 1> <Data 2>

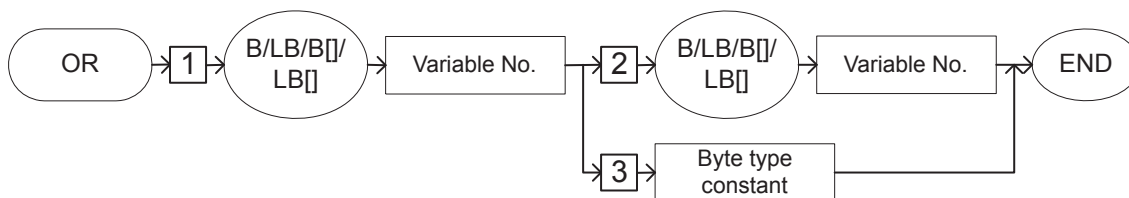

Explanation

1. B Variable number/LB Variable number/B [Array number]/LB [Array number]

Add the following tag.

No.	Tag	Explanation	Note
1	B Variable number/ LB Variable number/ B [Array number]/ LB [Array number]	Specifies the number of the byte type variable for which the logical sum is carried out.	<Data 1>

2. B Variable number/LB Variable number/B [Array number]/LB [Array number]/Byte type constant

Choose one of the tags from the following table.

No	Tag	Explanation	Note
2	B Variable number/ LB Variable number/ B [Array number]/ LB [Array number]	Specifies the number of the byte type variable for which the logical sum is carried out.	<Data 2>
3	Byte type constant	Specifies the byte type data for which the logical sum is carried out.	<Data 2>

2.3 Operating Instruction

Example

(1) SET B000 5
SET B010 10
OR B000 B010

Carries out the logical sum of B000 (0000 0101) and B010 (0000 1010), and stores the result (0000 1111=15) in B000.

NOT

SUBSET	STANDARD	EXPANDED
Not available	Available	Available

Function

Carries out the logical negation of Data 2, and stores the result in Data 1.

Construction

NOT <Data 1> <Data 2>

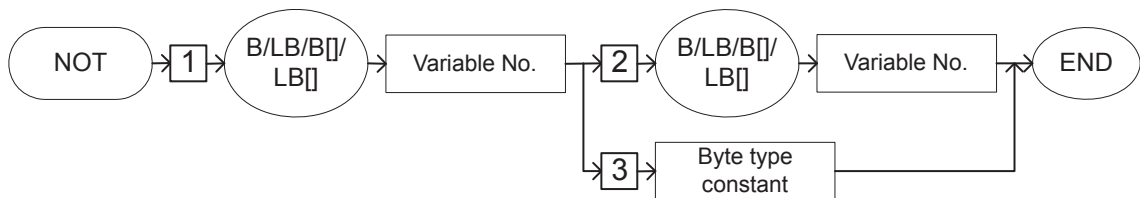

Explanation

1. B Variable number/LB Variable number/B [Array number]/LB [Array number]

Add the following tag.

No.	Tag	Explanation	Note
1	B Variable number/ LB Variable number/ B [Array number]/ LB [Array number]	Specifies the number of the byte type variable to store the result of logical negation.	<Data 1>

2. B Variable number/LB Variable number/B [Array number]/LB [Array number]/Byte type constant

Choose one of the tags from the following table.

No.	Tag	Explanation	Note
2	B Variable number/ LB Variable number/ B [Array number]/ LB [Array number]	Specifies the number of the byte type variable for which the logical negation is carried out.	<Data 2>
3	Byte type constant	Specifies the byte type data for which the logical negation is carried out.	<Data 2>

2.3 Operating Instruction

Example

(1) SET B000 0
SET B010 1
NOT B000 B010

Carries out the logical negation of B010 (0000 0001), and stores the result (1111 1110=254) in B000.

XOR

SUBSET	STANDARD	EXPANDED
Not available	Available	Available

Function

Carries out the logical exclusive OR of Data 1 and Data 2, and stores the result in Data 1.

Construction

XOR <Data 1> <Data 2>

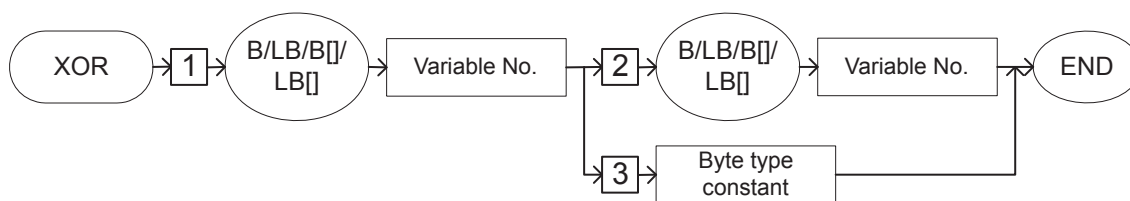

Explanation

1. B Variable number/LB Variable number/B [Array number]/LB [Array number]

Add the following tag.

No.	Tag	Explanation	Note
1	B Variable number/ LB Variable number/ B [Array number]/ LB [Array number]	Specifies the number of the byte type variable for which the exclusive OR is carried out.	<Data 1>

2. B Variable number/LB Variable number/B [Array number]/LB [Array number]/Byte type constant

Choose one of the tags from the following table.

No.	Tag	Explanation	Note
2	B Variable number/ LB Variable number/ B [Array number]/ LB [Array number]	Specifies the number of the byte type variable for which the exclusive OR is carried out.	<Data 2>
3	Byte type constant	Specifies the byte type data for which the exclusive OR is carried out.	<Data 2>

2.3 Operating Instruction

Example

(1) SET B000 1
SET B010 5
XOR B000 B010

Carries out the exclusive OR of B000 (0000 0001) and B010 (0000 0101), and stores the result (0000 0100=4) in B000.

MFRAME

SUBSET	STANDARD	EXPANDED
Not available	Available	Available

Function

Creates the user coordinates according to three types of position data; Data 1, Data 2, and Data 3.

Data 1 indicates the position data of the defined point ORG; Data 2 indicates the position data of the defined point XX; and Data 3 indicates the position data of the defined point XY.

Construction

MFRAME User coordinate designation <Data 1> <Data 2> <Data 3>

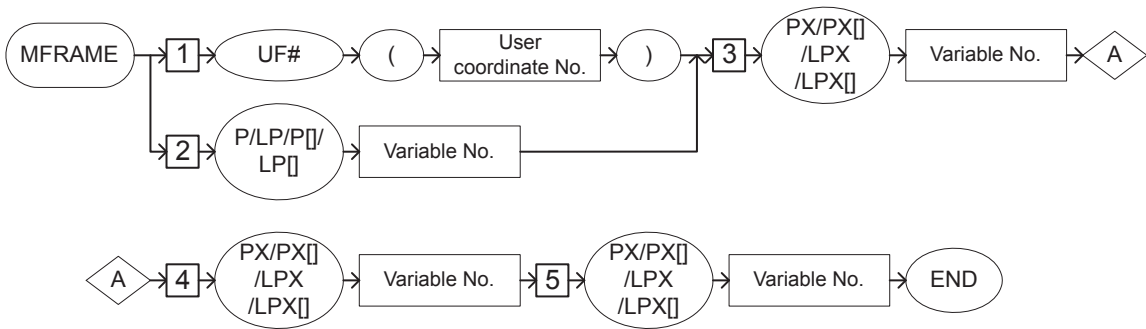

Explanation

1. UF# (User coordinate number)/P Variable number/LP Variable number/P [Array number]/LP [Array number]

Choose one of the tags from the following table.

No.	Tag	Explanation	Note
1	UF# (User coordinate number)	Allocates the number for the user coordinate to be created.	No.: 1 to 63 Variable B//D/LB/LI/LD can be used.
2	P Variable number/ LP Variable number/ P [Array number]/ LP [Array number]	Specifies the number of the position type variable where the coordinate values of the user coordinate to be created is stored.	

DX100

2.3 Operating Instruction

2. PX Variable number/LPX Variable number/PX [Array number]/LPX [Array number]

Add the following tag.

No.	Tag	Explanation	Note
3	PX Variable number/ LPX Variable number/ PX [Array number]/ LPX [Array number]	Specifies the number of the expanded position type variable where the position data of the user coordinate's defined point ORG has been stored.	<Data 1>

3. PX Variable number/LPX Variable number/PX [Array number]/LPX [Array number]

Add the following tag.

No.	Tag	Explanation	Note
4	PX Variable number/ LPX Variable number/ PX [Array number]/ LPX [Array number]	Specifies the number of the expanded position type variable where the position data of the user coordinate's defined point XX has been stored.	<Data 2>

4. PX Variable number/LPX Variable number/PX [Array number]/LPX [Array number]

Add the following tag.

No	Tag	Explanation	Note
5	PX Variable number/ LPX Variable number/ PX [Array number]/ LPX [Array number]	Specifies the number of the expanded position type variable where the position data of the user coordinate's defined point XY has been stored.	<Data 3>

Example

(1) MFRAME UF#(1) PX000 PX001 PX002

For the job R1, the user coordinate number 1 is created according to three types of position data; P000, P001, and P002 of the user coordinate system.

SETE

SUBSET	STANDARD	EXPANDED
Not available	Available	Available

Function

Sets Data 2 in the element of position type variable of Data 1.

Construction

SETE <Data 1> (Element number) <Data 2>

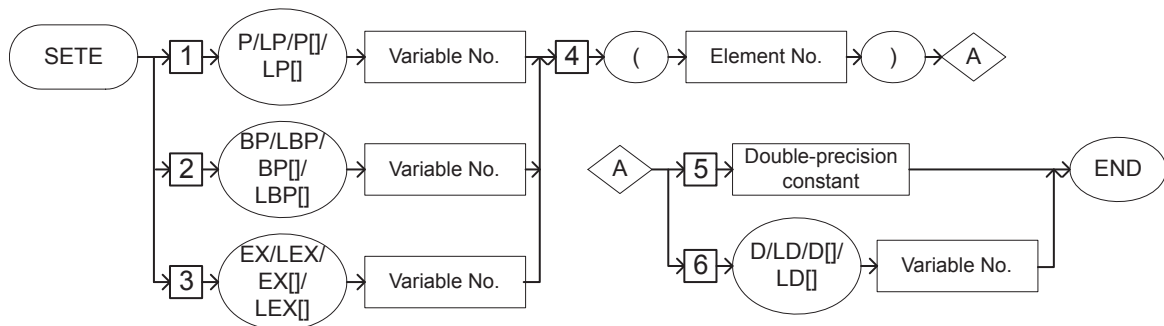

Explanation

1. P Variable number/LP Variable number/P [Array number]/LP [Array number]/BP Variable number/LBP Variable number/BP [Array number]/LBP [Array number]/BP [Array number]/LBP [Array number]/EX Variable number/LEX Variable number/EX [Array number]/LEX [Array number]

Choose one of the tags from the following table.

No.	Tag	Explanation	Note
1	P Variable number/ LP Variable number/ P [Array number]/ LP [Array number]	Specifies the number of the robot axis position type variable where Data 2 is set as an element.	<Data 1>
2	BP Variable number/ LBP Variable number/ BP [Array number]/ LBP [Array number]	Specifies the number of the base axis position type variable where Data 2 is set as an element.	<Data 1>
3	EX Variable number/ LEX Variable number/ EX [Array number]/ LEX [Array number]	Specifies the number of the station axis position type variable where Data 2 is set as an element.	<Data 1>

DX100

2.3 Operating Instruction

2. (Element number)

Add the following tag.

No.	Tag	Explanation	Note
4	(Element number)	Specifies the element of the position type variable to be set.	Element No.: 1 to 255 Variable B/LB can be used.

3. Double-precision type constant/D Variable number/
LD Variable number/D [Array number]/LD [Array
number]

Choose one of the tags from the following table.

No.	Tag	Explanation	Note
5	Double-precision type constant	Specifies the double-precision type data to be set.	<Data 2>
6	D Variable number/ LD Variable number/ D [Array number]/ LD [Array number]	Specifies the number of the double-precision type variable to be set.	<Data 2>

Example

(1) SETE P000 (3) 2000

2000 is set in the Z axis data of P000.

GETE

SUBSET	STANDARD	EXPANDED
Not available	Available	Available

Function

Stores the element of position type variable of Data 2 in Data 1.

Construction

GETE <Data 1> <Data 2> (Element number)

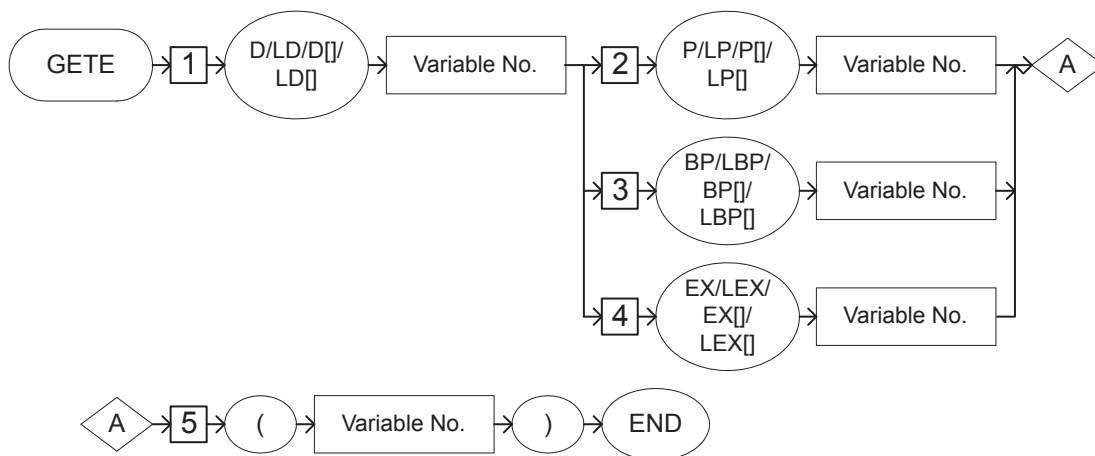

Explanation

1. D Variable number/LD Variable number/D [Array number]/LD [Array number]

Add the following tag.

No.	Tag	Explanation	Note
1	D Variable number/ LD Variable number/ D [Array number]/ LD [Array number]	Specifies the number of the double-precision type variable where the element of position type variable is stored.	<Data 1>

2.3 Operating Instruction

2. P Variable number/LP Variable number/P [Array number]/LP [Array number]/BP Variable number/LBP Variable number/BP [Array number]/LBP [Array number]/EX Variable number/LEX Variable number/EX [Array number]/LEX [Array number]

Choose one of the tags from the following table.

No.	Tag	Explanation	Note
2	P Variable number/ LP Variable number/ P [Array number]/ LP [Array number]	Specifies the number of the robot axis position type variable to be stored.	<Data 2>
3	BP Variable number/ LBP Variable number/ BP [Array number]/ LBP [Array number]	Specifies the number of the base axis position type variable to be stored.	<Data 2>
4	EX Variable number/ LEX Variable number/ EX [Array number]/ LEX [Array number]	Specifies the number of the station axis position type variable to be stored.	<Data 2>

3. (Element number)

Add the following tag.

No.	Tag	Explanation	Note
5	(Element number)	Specified the number of the of the position type variable element to be stored.	Element No.: 1 to 255 Variable B/LB can be used.

Example

(1) GETE D000 P000 (3)

The Z axis data of P000 is stored in D000.

GETS

SUBSET	STANDARD	EXPANDED
Not available	Available	Available

Function

Stores the system variable of Data 2 in Data 1.

Construction

GETS <Data 1> <Data 2>

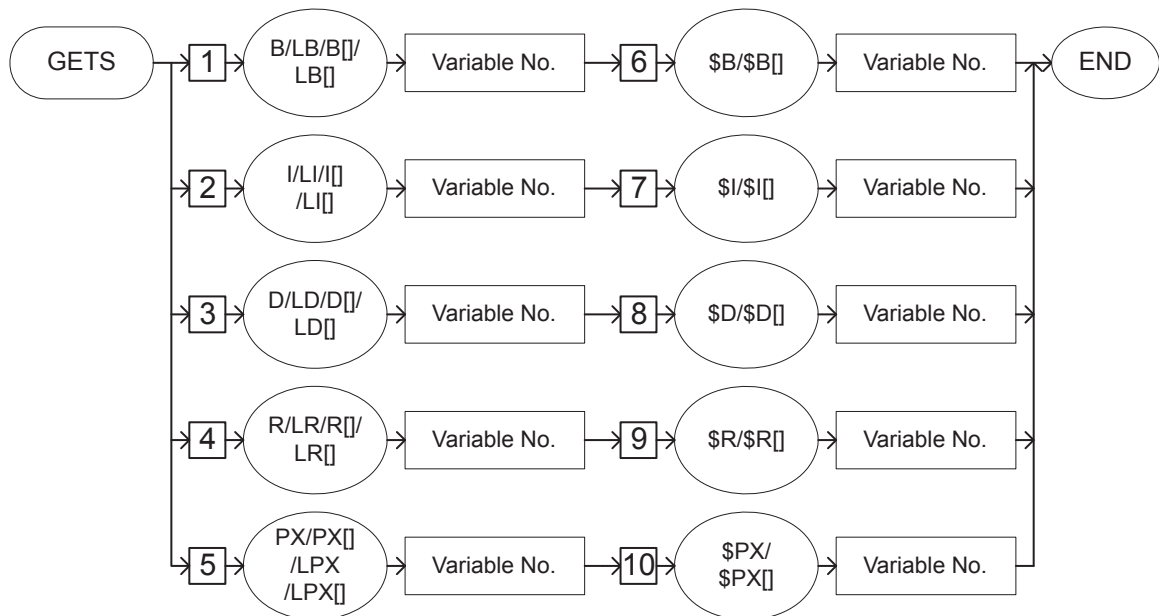

Explanation

1. B Variable number/LB Variable number/B [Array number]/LB [Array number]/I Variable number/LI Variable number/I [Array number]/LI [Array number]/D Variable number/LD Variable number/D [Array number]/LD [Array number]/R Variable number/LR Variable number/R [Array number]/LR [Array number]/PX Variable number/LPX Variable number/PX [Array number]/LPX [Array number]

Choose one of the tags from the following table.

No.	Tag	Explanation	Note
1	B Variable number/ LB Variable number/ B [Array number]/ LB [Array number]	Specifies the number of the byte type variable to store the system variable.	<Data 1>
2	I Variable number/ LI Variable number/ I [Array number]/ LI [Array number]	Specifies the number of the integer type variable to store the system variable.	<Data 1>
3	D Variable number/ LD Variable number/ D [Array number]/ LD [Array number]	Specifies the number of the double-precision type variable to store the system variable.	<Data 1>
4	R Variable number/ LR Variable number/ R [Array number]/ LR [Array number]	Specifies the number of the real-number type variable to store the system variable.	<Data1>
5	PX Variable number/ LPX Variable number/ PX [Array number]/ LPX [Array number]	Specifies the number of the expanded position type variable to store the system variable.	<Data 1>



System variable

The system variables are written by the controller system and can be referred only by a GETS instruction. The following system variables are available.

System Variable	Type	No.	Explanation
\$B type variable	Byte type	\$B002	Detected /Not detected by the optional SRCH instruction 0: Not detected, 1: Detected
		\$B008	Result of the optional SYSTART instruction 1: Normal termination, 0: Abnormal termination
		\$B009	Result of the SETFILE/GETFILE instruction 0: Normal termination, Other than 0: Abnormal termination
		\$B014	Result of the optional HSEN instruction 1: Setting status completed, 0: Others
		\$B016	The number of RIN#(1)s detected by the optional NSRCH instruction
		\$B017	The number of RIN#(2)s detected by the optional NSRCH instruction
		\$B018	The number of RIN#(3)s detected by the optional NSRCH instruction
		\$B019	The number of RIN#(4)s detected by the optional NSRCH instruction
		\$B020	The number of RIN#(5)s detected by the optional NSRCH instruction
\$PX type variable	Expanded position type	\$PX000	Current value (pulse type)
		\$PX001	Current value (XYZ type)
		\$PX002	Position detected by the optional SRCH instruction (pulse type)
		\$PX003	Position detected by the optional STCH instruction (XYZ type)
		\$PX004	Current value excluding the shift amount (XYZ type)
		\$PX005	Teaching position (pulse type)
		\$PX006	Operation target position (pulse type)
		\$PX040	Path correction amount (available only with the optional COMARC function)
		\$PX100 to \$PX149	RIN#(1)'s detected position by the optional NSRCH instruction (pulse type)

Continued



Continued

System Variable	Type	No.	Explanation
\$PX type variable	Expanded position type	\$PX150 to \$PX199	RIN#(1)'s detected position by the optional NSRCH instruction (XYZ type)
		\$PX200 to \$PX249	RIN#(2)'s detected position by the optional NSRCH instruction (pulse type)
		\$PX250 to \$PX299	RIN#(2)'s detected position by the optional NSRCH instruction (XYZ type)
		\$PX300 to \$PX349	RIN#(3)'s detected position by the optional NSRCH instruction (pulse type)
		\$PX350 to \$PX399	RIN#(3)'s detected position by the optional NSRCH instruction (XYZ type)
		\$PX400 to \$PX449	RIN#(4)'s detected position by the optional NSRCH instruction (pulse type)
		\$PX450 to \$PX499	RIN#(4)'s detected position by the optional NSRCH instruction (XYZ type)
		\$PX500 to \$PX549	RIN#(5)'s detected position by the optional NSRCH instruction (pulse type)
		\$PX550 to \$PX599	RIN#(5)'s detected position by the optional NSRCH instruction (XYZ type)

2. \$B Variable number/\$B [Array number]

When a B Variable number, LB Variable number, B [Array number], or LB [Array number] is selected from the table in part 1 of this Explanation, add the following tag.

No.	Tag	Explanation	Note
6	\$B Variable number/ \$B [Array number]	Specifies the number of the byte type system variable to be stored.	<Data 2>

2.3 Operating Instruction

3. \$I Variable number/\$I [Array number]

When an I Variable number, LI Variable number, I [Array number], or LI [Array number] is selected from the table in part 1 of this Explanation, add the following tag.

No.	Tag	Explanation	Note
7	\$I Variable number/ \$I [Array number]	Specifies the number of the integer type system variable to be stored.	<Data 2>

4. \$D Variable number/\$D [Array number]

When a D Variable number, LD Variable number, D [Array number], or LD [Array number] is selected from the table in part 1 of this Explanation, add the following tag.

No.	Tag	Explanation	Note
8	\$D Variable number/ \$D [Array number]	Specifies the number of the double-precision type system variable to be stored.	<Data 2>

5. \$R Variable number/\$R [Array number]

When an R Variable number, LR Variable number, R [Array number], or LR [Array number] is selected from the table in part 1 of this Explanation, add the following tag.

No.	Tag	Explanation	Note
9	\$R Variable number/ \$R [Array number]	Specifies the number of the real-number type system variable to be stored.	<Data 2>

6. \$PX Variable number/\$PX [Array number]

When a PX Variable number, LPX Variable number, PX [Array number], or LPX [Array number] is selected from the table in part 1 of this Explanation, add the following tag.

No.	Tag	Explanation	Note
10	\$PX Variable number/ \$PX [Array number]	Specifies the number of the expanded position type system variable to be stored.	<Data 2>

Example

(1) GETS B000 \$B002

The result of the SRCH instruction is stored in B000.

(2) GETS PX000 \$PX000

For the job R1, the pulse type current value is stored in P000.

SQRT

SUBSET	STANDARD	EXPANDED
Not available	Available	Available

Function

Calculates the square root of Data 2, and stores the result in Data 1.

Construction

SQRT <Data 1> <Data 2>

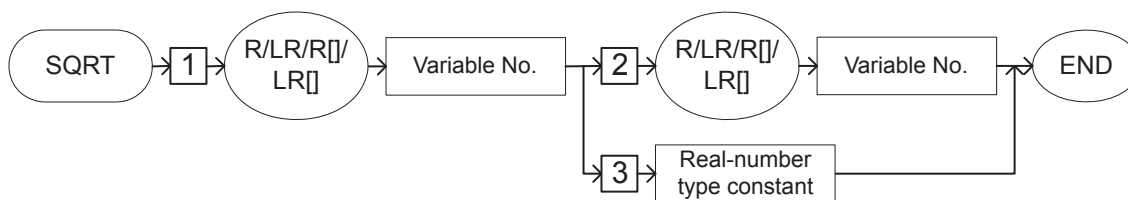

Explanation

1. R Variable number/LR Variable number/R [Array number]/LR [Array number]

Add the following tag.

No.	Tag	Explanation	Note
1	R Variable number/ LR Variable number/ R [Array number]/ LR [Array number]	Specifies the number of the real-number type variable to store the result.	<Data 1>

2. R Variable number/LR Variable number/R [Array number]/LR [Array number]/Real-number type constant

Choose one of the tags from the following table.

No.	Tag	Explanation	Note
2	R Variable number/ LR Variable number/ R [Array number]/ LR [Array number]	Specifies the number of the real-number type variable whose square root is calculated.	<Data 2>
3	Real-number type constant	Specifies the real-number type data whose square root is calculated.	<Data 2>

2.3 Operating Instruction

Example

(1) SQRT R000 2

1.414214E + 00 is stored in R000.

SIN

SUBSET	STANDARD	EXPANDED
Not available	Available	Available

Function

Calculates the sine of Data 2, and stores the result in Data 1.

Construction

SIN <Data 1> <Data 2>

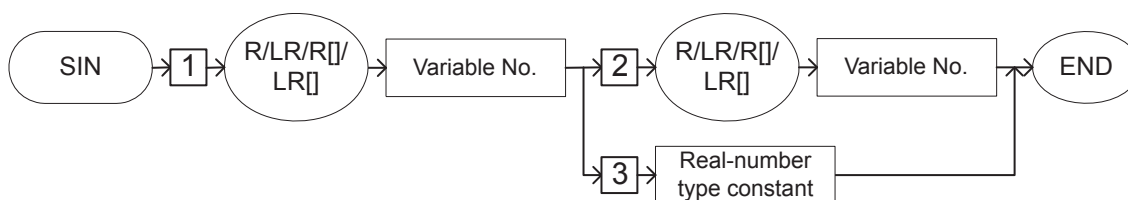

Explanation

1. R Variable number/LR Variable number/R [Array number]/LR [Array number]

Add the following tag.

No.	Tag	Explanation	Note
1	R Variable number/ LR Variable number/ R [Array number]/ LR [Array number]	Specifies the number of the real-number type variable to store the result.	<Data 1>

2. R Variable number/LR Variable number/R [Array number]/LR [Array number]/Real-number type constant

Choose one of the tags from the following table.

No.	Tag	Explanation	Note
2	R Variable number/ LR Variable number/ R [Array number]/ LR [Array number]	Specifies the number of the real-number type variable whose sine is calculated.	<Data 2>
3	Real-number type constant	Specifies the real-number type data whose sine is calculated.	<Data 2>

2.3 Operating Instruction

Example

(1) SIN R000 60

8.660254E - 01 is stored in R000.

COS

SUBSET	STANDARD	EXPANDED
Not available	Available	Available

Function

Calculates the cosine of Data 2, and stores the result in Data 1.

Construction

COS <Data 1> <Data 2>

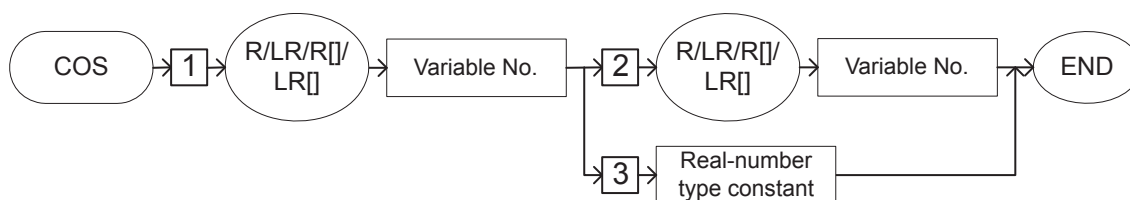

Explanation

1. R Variable number/LR Variable number/R [Array number]/LR [Array number]

Add the following tag.

No.	Tag	Explanation	Note
1	R Variable number/ LR Variable number/ R [Array number]/ LR [Array number]	Specifies the number of the real-number type variable to store the result.	<Data 1>

2. R Variable number/LR Variable number/R [Array number]/LR [Array number]/Real-number type constant

Choose one of the tags from the following table.

No.	Tag	Explanation	Note
2	R Variable number/ LR Variable number/ R [Array number]/ LR [Array number]	Specifies the number of the real-number type variable whose cosine is calculated.	<Data 2>
3	Real-number type constant	Specifies the real-number type data whose cosine is calculated.	<Data 2>

2.3 Operating Instruction

Example

(1) COS R000 60

5.000000E - 01 is stored in R000.

ATAN

SUBSET	STANDARD	EXPANDED
Not available	Available	Available

Function

Calculates the arc tangent of Data 2, and stores the result in Data 1.

Construction

ATAN <Data 1> <Data 2>

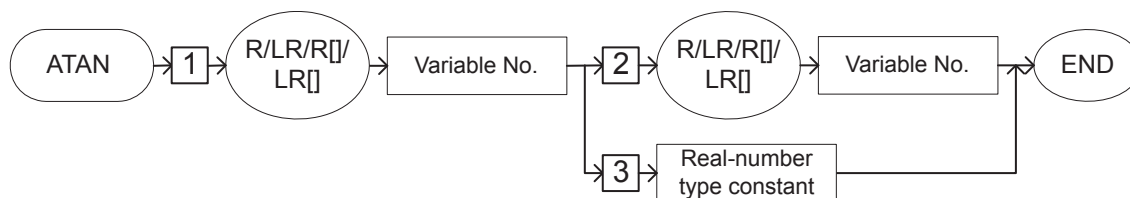

Explanation

1. R Variable number/LR Variable number/R [Array number]/LR [Array number]

Add the following tag.

No.	Tag	Explanation	Note
1	R Variable number/ LR Variable number/ R [Array number]/ LR [Array number]	Specifies the number of the real-number type variable to store the result.	<Data 1>

2. R Variable number/LR Variable number/R [Array number]/LR [Array number]/Real-number type constant

Choose one of the tags from the following table.

No.	Tag	Explanation	Note
2	R Variable number/ LR Variable number/ R [Array number]/ LR [Array number]	Specifies the number of the real-number type variable whose arc tangent is calculated.	<Data 2>
3	Real-number type constant	Specifies the real-number type data whose arc tangent is calculated.	<Data 2>

2.3 Operating Instruction

Example

(1) ATAN R000 60

8.904516E + 01 is stored in R000.

MULMAT

SUBSET	STANDARD	EXPANDED
Not available	Available	Available

Function

Calculates the matrix multiplication of Data 2 and Data 3, and stores the result in Data 1.

Construction

MULMAT <Data 1> <Data 2> <Data 3>

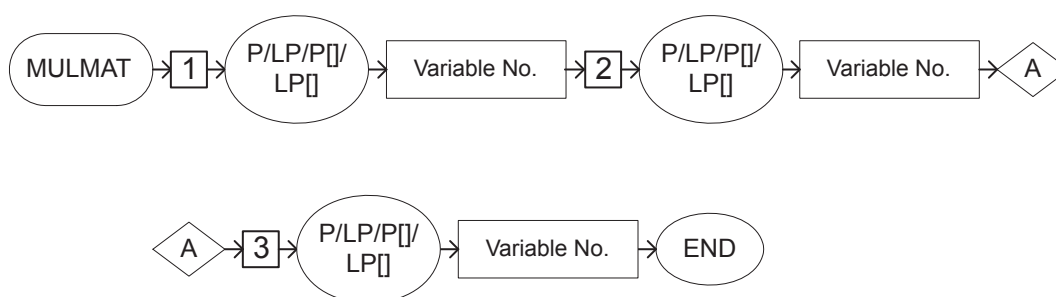

Explanation

1. P Variable number/LP Variable number/P [Array number]/LP [Array number]

Add the following tag.

No.	Tag	Explanation	Note
1	P Variable number/ LP Variable number/ P [Array number]/ LP [Array number]	Specifies the number of the position type variable to store the result.	<Data 1>

2. P Variable number/LP Variable number/P [Array number]/LP [Array number]

Add the following tag.

No.	Tag	Explanation	Note
2	P Variable number/ LP Variable number/ P [Array number]/ LP [Array number]	Specifies the number of the position type variable for which the matrix multiplication is calculated.	<Data 2>

2.3 Operating Instruction

3. P Variable number/LP Variable number/P [Array number]/LP [Array number]

Add the following tag.

No.	Tag	Explanation	Note
3	P Variable number/ LP Variable number/ P [Array number]/ LP [Array number]	Specified the number of the position type variable for which the matrix multiplication is calculated.	<Data 3>

Example



MULMAT and INVMAT instructions

The amount of shift for a three-dimensional shift can be obtained by using the MULMAT and INVMAT instructions.

The instructions, exclusive to the DX100, to obtain the shift amount are used for the optional three-dimensional shift function. However, the amount of the three-dimensional shift can be also obtained by using the standard instructions, MULMAT and INVMAT.

The target value for a three-dimensional shift can be calculated by the following equation.

$$P_{\text{new}} = P_{3d} \times P_{\text{old}}$$

Where P_{new}: Target position after a three-dimensional shift

P_{3d}: Three-dimensional shift amount

P_{old}: Taught position

The amount of a three-dimensional shift can be obtained as follows:

$$P_{3d} = P_{\text{new}} \times P_{\text{old}}^{-1}$$

- (1) `MOVL P010 V=500`
`GETS PX020 $PX001` Stores the current XYZ type value in P020.
`INVMAT P021 P010` Calculates the inverse matrix of the taught position.
`MULMAT P023 P020 P021` The amount of the three-dimensional

INVMAT

SUBSET	STANDARD	EXPANDED
Not available	Available	Available

Function

Calculates the inverse matrix of Data 2, and stores the result in Data 1.

Construction

INVMAT <Data 1> <Data 2>

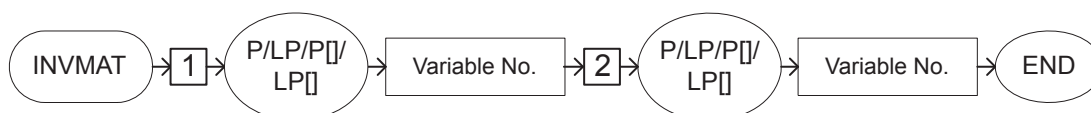

Explanation

1. P Variable number/LP Variable number/P [Array number]/LP [Array number]

Add the following tag.

No.	Tag	Explanation	Note
1	P Variable number/ LP Variable number/ P [Array number]/ LP [Array number]	Specifies the number of the position type variable to store the result.	<Data 1>

2. P Variable number/LP Variable number/P [Array number]/LP [Array number]

Add the following tag.

No.	Tag	Explanation	Note
2	P Variable number/ LP Variable number/ P [Array number]/ LP [Array number]	Specifies the number of the position type variable for which the inverse matrix is calculated.	<Data 2>

Example

- | | |
|-----------------------|---|
| (1) MOVL P010 V=500 | |
| GETS PX020 \$PX001 | Stores the current XYZ type value in P020. |
| INVMAT P021 P010 | Calculates the inverse matrix of the taught position. |
| MULMAT P023 P020 P021 | The amount of the three-dimensional |

SETFILE

SUBSET	STANDARD	EXPANDED
Not available	Available	Available

Function

Changes the specified data of the specified condition file to the numeric data of Data 1.

Specify the data of the condition file to be changed by its element number.

Construction

SETFILE Condition file specification (Element number) <Data 1>

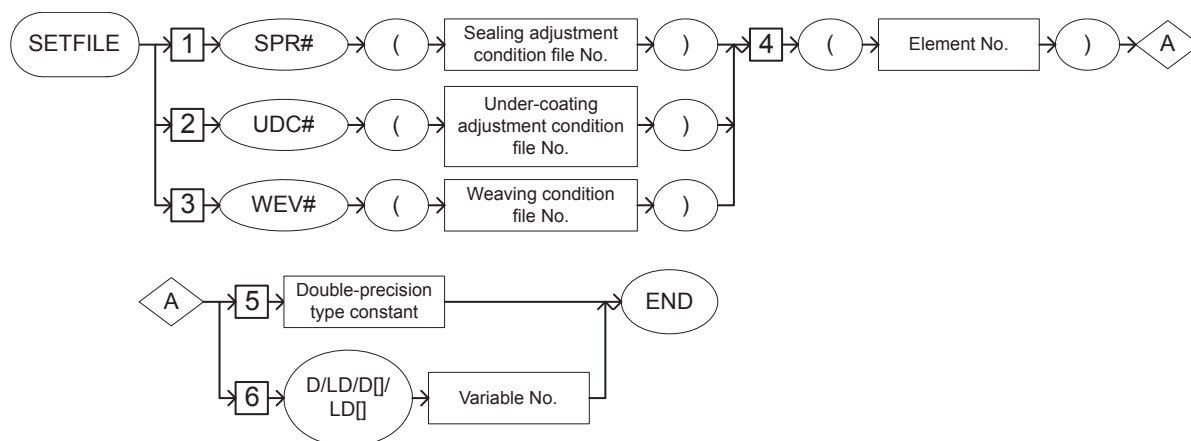

Explanation

1. SPR# (Sealing adjustment condition file number)/UDC# (Under-coating adjustment condition file number)/WEV# (Weaving condition file number)

2.3 Operating Instruction

Choose one of the tags from the following table.

No.	Tag	Explanation	Note
1	SPR# (Sealing adjustment condition file number)	Specifies the number of the sealing (spray) adjustment condition file.	No.: 1 Variable B/I/D/LB/LI/LD can be used. Available only with the optional servo sealing gun function.
2	UDC# (Under-coating adjustment condition file number)	Specifies the number of the number of the under-coating adjustment condition file.	No.: 1 Variable B/I/D/LB/LI/LD can be used. Available only with the optional under-coating function.
3	WEV# (Weaving condition file number)	Specifies the number of the weaving condition file.	No.: 1 to 16 Variable B/I/D/LB/LI/LD can be used.

2. (Element number)

Add the following tag.

No.	Tag	Explanation	Note
4	(Element number)	Specifies the element number of the condition file data to be changed.	Element No.: 1 to 255 Variable B/LB can be used.

3. Double-precision type constant/D Variable number/
LD Variable number/D [Array number]/LD [Array number]

Choose one of the tags from the following table.

No.	Tag	Explanation	Note
5	Double-precision type constant	Specifies the double-precision type data to be changed.	<Data 1>
6	D Variable number/ LD Variable number/ D [Array number]/ LD [Array number]	Specifies the number of the double-precision type variable of the data to be changed.	<Data 1>



Element number of each condition file

The element number of each item in the condition file is shown below.

<Weaving condition file>

Element No.	Item	Units	Remarks
1	MODE		
2	SMOOTHING		
3	SPEED		
4	FREQUENCY	0.1 Hz	
5	AMPLITUDE (ACTIVE IN	0.001	
6	PATTERN VERTICAL	0.001	
7	PATTERN HORIZONTAL	0.001	
8	PATTERN ANGLE	0.01 deg.	
9	ANGLE	0.01 deg.	
10	TIMER MODE (SECT 1 to 4)		Stop positions 1 to 4 (SECT 1 to 4) designated by bit
11 to 14	MOVING TIME	0.1 sec.	Sections 1 to 4
15 to 18	TIMER (timer count)	0.1 sec.	Duration of a pause
19	HOVER WEAVING SET		Optional
20	HOVER WEAVING TIME	0.01 sec.	Optional
21	HOVER WEAVING INPUT		Optional

For details of the weaving condition file, refer to "Chapter 11.10 Weaving Condition File" in DX100 OPERATOR'S MANUAL FOR ARC WELDING (RE-CSO-A031).

Example

(1) SETFILE WEV#(1) (5) 3500

Changes the amplitude setting in the weaving condition file number 1 to 3.500 mm.

GETFILE

SUBSET	STANDARD	EXPANDED
Not available	Available	Available

Function

Stores the data of the specified condition file in Data 1.
Specify the data of the condition file to be stored by its element number.

Construction

GETFILE <Data 1> Condition file designation (Element number)

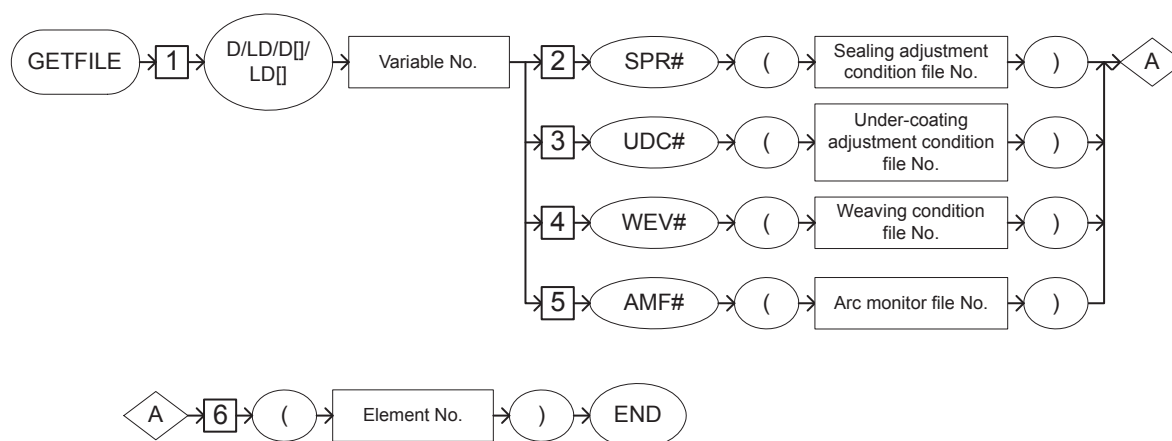

Explanation

1. D Variable number/LD Variable number/D [Array number]/LD [Array number]

Add the following tag.

No.	Tag	Explanation	Note
1	D Variable number/ LD Variable number/ D [Array number]/ LD [Array number]	Specifies the number of the double-precision type variable to store the data.	<Data 1>

2.3 Operating Instruction

2. SPR# (Sealing adjustment condition file number)/
UDC# (Under-coating adjustment condition file
number)/WEV# (Weaving condition file number)/
AMF# (Arc monitor file number)

Choose one of the tags from the following table.

No.	Tag	Explanation	Note
2	SPR# (Sealing adjustment condition file number)	Specifies the number of the sealing (spray) adjustment condition file.	No.: 1 Variable B//D/LB/LI/LD can be used. Available only with the optional servo sealing gun function.
3	UDC# (Under-coating adjustment condition file number)	Specifies the number of the under-coating adjustment condition file.	No.: 1 Variable B//D/LB/LI/LD can be used. Available only with the optional under-coating function.
4	WEV# (Weaving condition file number)	Specifies the number of the weaving condition file.	No.: 1 to 16 Variable B//D/LB/LI/LD can be used.
5	AMF# (Arc monitor file number)	Specifies the number of the arc monitor file.	No.: 1 to 50 Variable B//D/LB/LI/LD can be used. Available only with the optional arc monitor function.

3. (Element number)

Add the following tag.

No.	Tag	Explanation	Note
6	(Element number)	Specifies the element number of the condition file data to be stored.	Element No.: 1 to 255 Variable B/LB can be used.

Example

(1) GETFILE D000 WEV#(1) (6)

Stores the vertical distance (PATTERN VERTICAL) in the weaving condition file number 1 in D000.

SETREG

SUBSET	STANDARD	EXPANDED
Not available	Available	Available

Function

Copies the specified integer type variable data into the register.

Construction

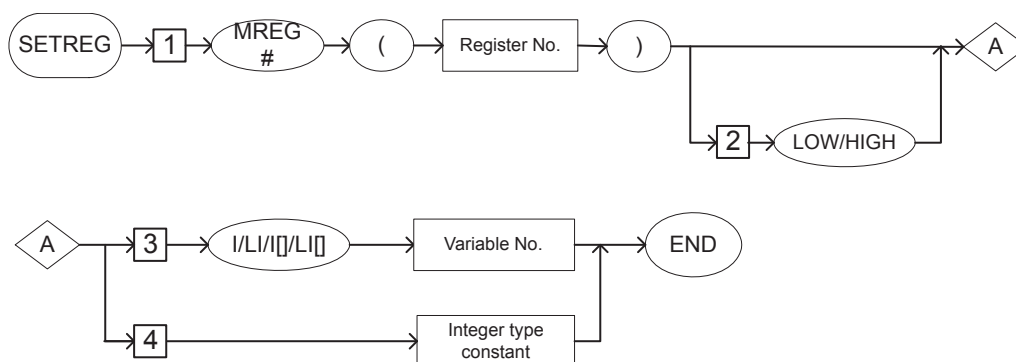

Explanation

1. MREG# (Register number)

No.	Tag	Explanation	Note
1	MREG# (Register number)	Specifies the register number to save the data.	No.: 0 to 499 Variable B/I/D/LB/LI/LD can be used.

2. LOW/HIGH

No.	Tag	Explanation	Note
2	LOW/HIGH	Specifies when copying the data into the lower/higher 8 bits of the register.	

3. I Variable number/LI Variable number/I [Array number]/LI [Array number]

No.	Tag	Explanation	Note
3	I Variable number/ LI Variable number/ I [Array number]/ LI [Array number]	Specifies the data number to be saved in the register.	
4	Integer type variable	Input the data to be saved in the register.	

GETREG

SUBSET	STANDARD	EXPANDED
Not available	Available	Available

Function

Copies the specified register data into the integer type variable.

Construction

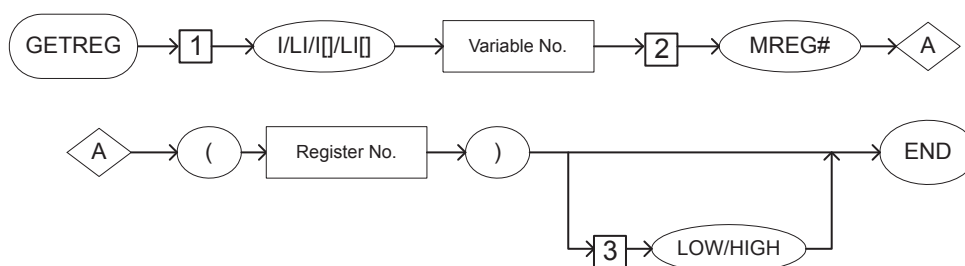

Explanation

1. I Variable number/LI Variable number/I [Array number]/LI [Array number]

No.	Tag	Explanation	Note
1	I Variable number/ LI Variable number/ I [Array number]/ LI [Array number]	Specifies the number of the integer type variable to save the register data.	

2. MREG# (Register number).

No.	Tag	Explanation	Note
2	MREG# (Register number)	Specifies the desired register number to be saved into the integer type variable.	No.: 0 to 499 Variable B/I/D/LB/LI/LD can be used.

3. LOW/HIGH

No.	Tag	Explanation	Note
3	LOW/HIGH	Specifies when saving the lower/higher 8 bits out of 16 bits register.	

GETPRM

SUBSET	STANDARD	EXPANDED
Not available	Available	Available

Function

Stores the specified parameter into the specified variable.
It can be only used at the macro job when the macro command (optional) is valid.

Construction

GETPRM <Data1> <Data2> <Data3> <Data4>

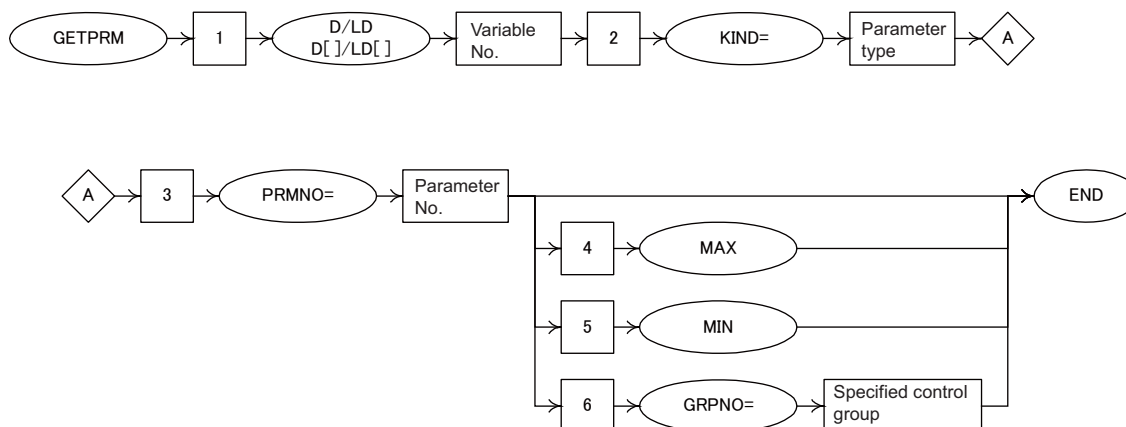

Explanation

1. D Variable number /LD Variable number /D [Array number] /LD [Array number]

Add the following tag.

No.	Tag	Explanation	Note
1	D Variable number/ LD Variable number/ D [Array number]/ LD [Array number]	Specifies the number of the double precision type variable to store the data.	<Data1>

2. KIND=Parameter type

Add the following tag.

No.	Tag	Explanation	Note
2	KIND=parameter type	Specifies the parameter type. 4: S1CxG 5: S2C 6: S3C 7: S4C	<Data2> No.: 4 to 7 Variable B/I/D/B[]/I[]/D[]/ LB/LI/LD/LB[]/LI[]/LD[] can be used.

2.3 Operating Instruction

3. PRMNO=Parameter No.

No.	Tag	Explanation	Note
3	PRMNO=parameter No.	Specifies the parameter No.	<Data3> Variable B//D/B[]/I[]/D[]/ LB/LI/LD/LB[]/LI[]/LD[] can be used.

4. MAX (Specifying the maximum value)

MIN (Specifying the minimum value)

GRPNO=Specifying the control group

The following tag can be added or omitted. However, one of the following tags must be selected when KIND=4(S1CxG) is specified.

No.	Tag	Explanation	Note
4	MAX	Specifies the largest specified parameter value in the control group which is included the job to operate the GETPRM command. The job without control group which operates the GETPRM command cannot retrieve the parameter value.	<Data4>
5	MIN	Specifies the smallest specified parameter value in the control group which is included the job to operate the GETPRM command. The job without control group which operates the GETPRM command cannot retrieve the parameter value.	<Data4>
6	GRPNP=Specifies control group	Specifies the control group	<Data4> Control group: 1 to 32 Variable B//D/B[]/I[]/D[]/ LB/LI/LD/LB[]/LI[]/LD[] can be used.

Example

GETPRM D000 KIND=4 PRMNO=400 GRPNO=1

Stores the soft limit values (+) of the Robot 1to D000.

SETPRM

SUBSET	STANDARD	EXPANDED
Not available	Available	Available

Function

Changes the specified parameter into the specified variable.
It can be only used at the macro job when the macro command (optional) is valid.

Construction

SETPRM <Data1> <Data2> <Data3> <Data4>

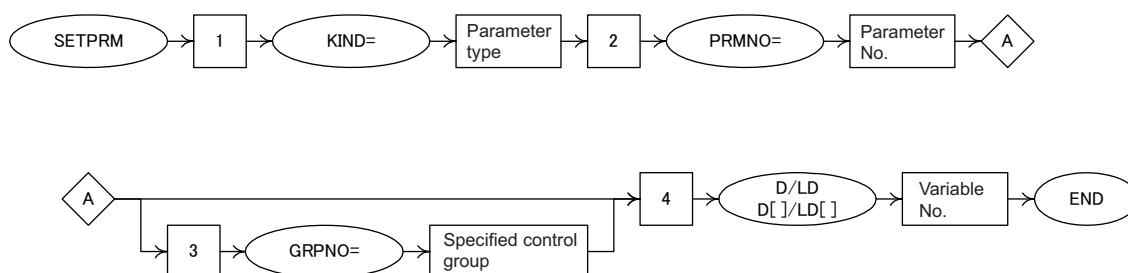

Explanation

1. KIND=Parameter type
Add the following tag.

No.	Tag	Explanation	Note
1	KIND=parameter type	Specifies the parameter type. 5: S2C 6: S3C	<Data1> Type: 5 to 6 Variable B/I/D/B[]/I[]/D[]/ LB/LI/LD/LB[]/LI[]/LD[] can be used.

2. PRMNO=Parameter No.
Add the following tag.

No.	Tag	Explanation	Note
2	PRMNO=Parameter No.	Specifies the parameter number. The parameter range varies by specifying KIND=parameter type. KIND=5(S2C) : 3 to 194 KIND=6(S3C) : 64 to 1087	<Data2> No.: 4 to 7 Variable B/I/D/B[]/I[]/D[]/ LB/LI/LD/LB[]/LI[]/LD[] can be used.

2.3 Operating Instruction

3. GRPNO=Specifies control group

The following tag can be added or omitted.

No.	Tag	Explanation	Note
3	GRPNO=Specifies control group	Specifies the control group No. Tag is not used at this time for future use.	<Data3> Variable B/I/D/B[]/I[]/D[]/ LB/LI/LD/LB[]/LI[]/LD[] can be used.

4. D Variable number/ LD Variable number /D [Array number]/ LD [Array number]

Add he following tag.

No.	Tag	Explanation	Note
4	D Variable number/ LD Variable number/ D [Array number]/ LD [Array number]	Specifies the number of the double precision type variable to store the data.	<Data4>

Example

In case of executing SETPRM KIND=5 PRMNO=67 D000 when D000 is 2, the signal method can be switched to the robot coordinate from cubic/ axis interference.

2.4 Move Instruction

MOVJ

SUBSET	STANDARD	EXPANDED
Available	Available	Available

Function

Moves to the teaching position by joint interpolation.

Construction

The tag which can be used is limited by the type of the job.

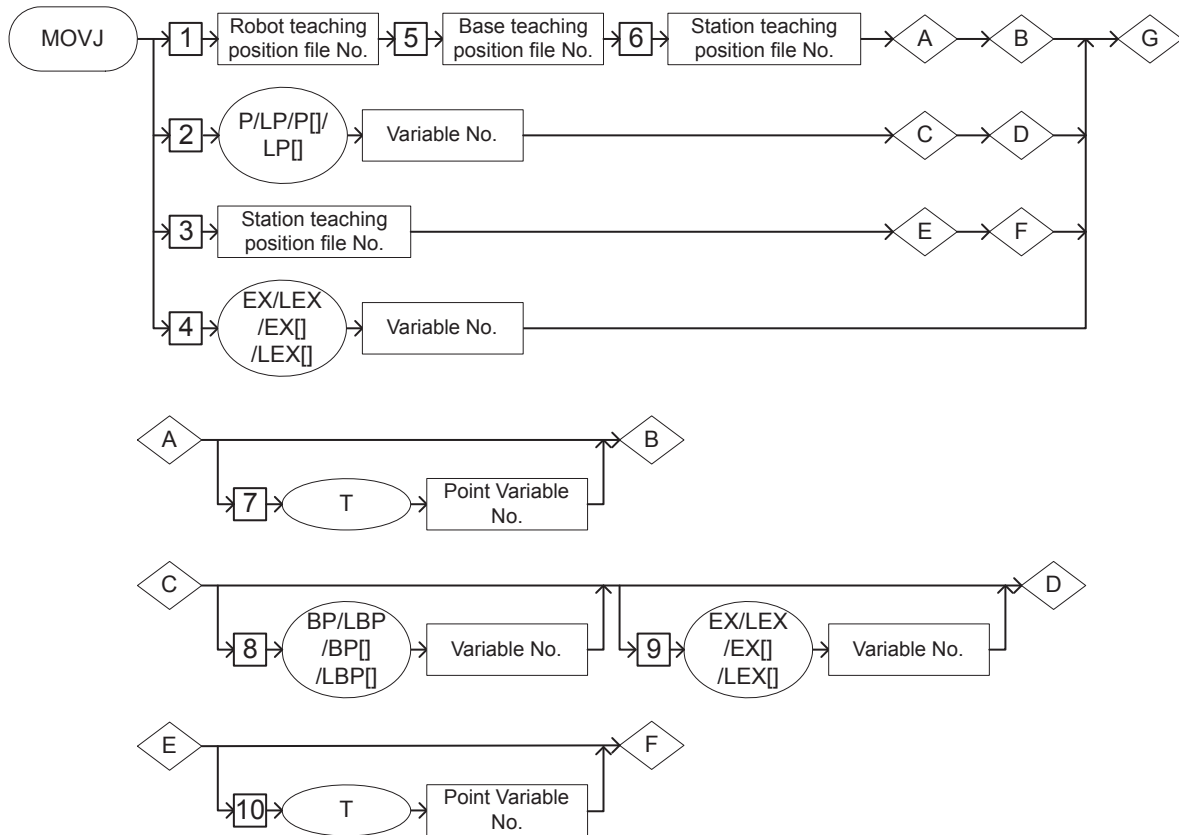

2.4 Move Instruction

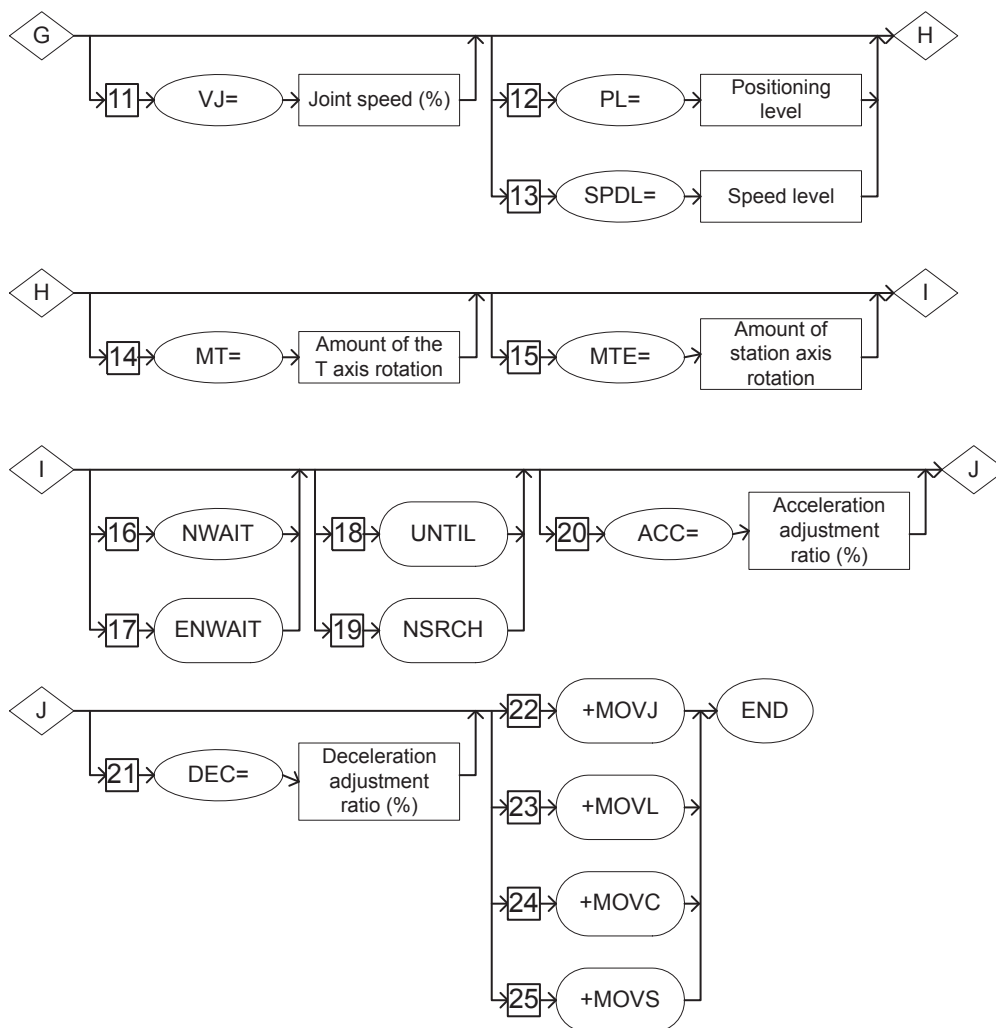

Table 2-1: Job Type and Control Group

No.	Job Type	Control Group	Remarks
1	Single	One manipulator (standard)	
2	Single	One manipulator with base axis	
3	Single	One manipulator with station axis	
4	Single	One manipulator with base and station axes	
5	Single	Station axis only	
6	Coordinated	Two manipulators	Optional
7	Coordinated	Two manipulators with base axis	Optional

2.4 Move Instruction

Table 2-2: Availability of Each Tag

No	Tag	Control Group							Note
		1	2	3	4	5	6	7	
1	Robot teaching position file number	●	●	●	●	×	●	●	
2	P/LP/P[]/LP[]	●	●	●	●	×	●	●	
3	Station teaching position file number	×	×	×	×	●	×	×	
4	EX/LEX/EX[]/LEX[]	×	×	×	×	●	×	×	
5	Base axis teaching position file number	×	●	×	●	×	×	×	
6	Station teaching position file number	×	×	●	●	×	×	×	
7	T	○	○	○	○	×	○	○	Optional
8	BP/LBP/BP[]/LBP[]	×	●	×	●	×	×	●	
9	EX/LEX/EX[]/LEX[]	×	×	●	●	×	×	×	
10	T	×	×	×	×	○	×	×	Optional
11	VJ=	●	●	●	●	●	●	●	
12	PL=	●	●	●	●	●	●	●	
13	SPDL=	○	○	○	○	×	○	○	Optional
14	MT=	○	○	○	○	×	×	×	Optional
15	MTE=	×	×	○	○	○	×	×	Optional
16	NWAIT	●	●	●	●	●	●	●	
17	ENWAIT	○	○	○	○	○	○	○	Optional
18	UNTIL	●	●	●	●	●	●	●	
19	NSRCH	○	○	○	○	○	○	○	Optional
20	ACC=	●	●	●	●	●	●	●	
21	DEC=	●	●	●	●	●	●	●	
22	+MOVJ	×	×	×	×	×	○	○	Optional
23	+MOVL	×	×	×	×	×	○	○	Optional
24	+MOVC	×	×	×	×	×	○	○	Optional
25	+MOVS	×	×	×	×	×	○	○	Optional

●: Available

○: Available only with optional function enabled

×: Not available

2.4 Move Instruction

Explanation

1. Robot teaching position file number /P Variable number /LP Variable number /P [Array number] /LP [Array number] /Station teaching position file number /EX Variable number /LEX Variable number / EX [Array number] /LEX [Array number]

Choose one of the tags from the following table.

No	Tag	Explanation	Note
1	Robot teaching position file number	The robot axis teaching position in each step is written in this file unconditionally when the step is taught. This teaching position cannot be edited.	On the job display, this tag is not displayed.
2	P Variable number/ LP Variable number/ P [Array number]/ LP [Array number]	Specifies the position variable number of the robot axis. Moves to the position data set in the variable of the specified number.	Variable number: 000 to 127
3	Station teaching position file number	The station axis teaching position in each step is written in this file unconditionally when the step is taught. This teaching position cannot be edited.	On the job display, this tag is not displayed.
4	EX Variable number/ LEX Variable number/ EX [Array number]/ LEX [Array number]	Specifies the position variable number of the station axis. Moves to the position data set in the variable of the specified number.	Variable number: 000 to 127

**Position Variables**

There are the following three kinds of position variables.

Robot axis : P000-P127

Base axis : BP000-BP127

Station axis : EX000-EX127

A position variable can store the position data as pulse type or XYZ type.

**Local Variables and Arrangement Variables**

Local variables and arrangement variables are available only for the expanded instruction set.

P000 and P[0] show the same one.

2.4 Move Instruction

2. Base Teaching Position File Number

When a robot teaching position file number is selected from the table in part 1 of this Explanation, add the following tag.

No	Tag	Explanation	Note
5	Base teaching position file number	The base axis teaching position in each step is written in this file unconditionally when the step is taught. This teaching position cannot be edited.	On the job display, this tag is not displayed.

3. Station Teaching Position File Number

When a robot teaching position file number is selected from the table in part 1 of this Explanation, add the following tag.

No	Tag	Explanation	Note
6	Station teaching position file number	The station axis teaching position in each step is written in this file unconditionally when the step is taught. This teaching position cannot be edited.	On the job display, this tag is not displayed.

4. T Point Variable number

When a robot teaching position file number is selected from the table in part 1 of this Explanation, the following tag can be added or omitted.

No	Tag	Explanation	Note
7	T Point Variable number	Specifies the number of the point variable. The point variable manages the teaching positions registered in the job, and is used to move the manipulator to the same position several times in one job.	Available only with the optional point variable function.

5. BP Variable number /LBP Variable number /BP [Array number] /LBP [Array number]

When a P Variable number, LP Variable number, P [Array number], or LBP [Array number] is selected from the table in part 1 of this Explanation, the following tag can be added.

No	Tag	Explanation	Note
8	BP Variable number/ LBP Variable number/ BP [Array number] / LBP [Array number]	Specifies the position variable number of the base axis. Moves to the position data set in the variable of the specified number.	Variable number: 000 to 127

2.4 Move Instruction

6. EX Variable number /LEX Variable number /EX [Array number] /LEX [Array number]

When a P Variable number, LP Variable number, P [Array number], or LP [Array number] is selected from the table in part 1 of this Explanation, the following tag can be added.

No	Tag	Explanation	Note
9	EX Variable number/ LEX Variable number/ EX [Array number]/ LEX [Array number]	Specifies the position variable number of the station axis. Moves to the position data set in the variable of the specified number.	Variable number: 000 to 127

7. T Point Variable number

When a robot teaching position file number is selected from the table in part 1 of this Explanation, the following tag can be added or omitted.

No	Tag	Explanation	Note
10	T Point Variable number	Specifies the number of the point variable. The point variable manages the teaching positions registered in the job, and is used to move the manipulator to the same position several times in one job.	Available only with the optional point variable function.

8. VJ=Joint speed

The following tag can be added or omitted.

No	Tag	Explanation	Note
11	VJ=Joint speed	Specifies the joint speed. The joint speed is shown in the ratio to the highest speed. When the joint speed is omitted, the operation is performed at the speed decided beforehand.	Speed: 0.01% to 100.00% Variable B/B[]/LB/LB[]/I/I[]/LI/LI[]/D/D[]/ LD/LD[] can be used. (Units: 0.01%)

9. PL=Position level /SPDL=Speed level

Choose one of the tags from the following table.

No	Tag	Explanation	Note
12	PL=Position level	Specifies the position level. The approach level when the manipulator passes the position where the teaching procedure was performed is called a positioning level.	Level: 0 to 8 Variable B/B[]/LB/LB[]/I/I[]/LI/LI[]/D/D[]/ LD/LD[] can be used.
13	SPDL=Speed level	Specifies the speed level. The speed level is the tag for the robot to end the execution of the move instruction in the state of servo float control, and to confirm the state which has stopped. The operation ends when the speed feedback pulse of all axes goes below a constant value, and the manipulator is considered to have stopped.	Level: Only 0 Available only with the optional servo-float function. Refer to the servo-float function for details.



Position level

The approach level when the manipulator passes the position where the teaching procedure was performed is called a position level.

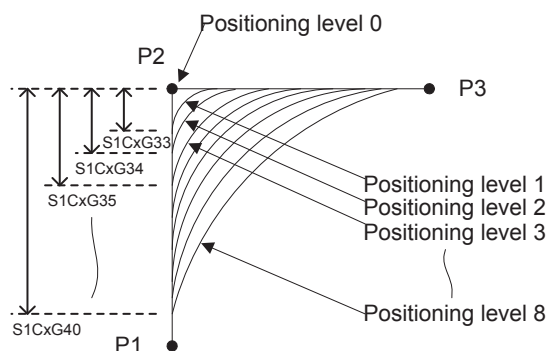

The approach level is set by the following parameters.
(position zone)

Position level 1: S1CxG33(μm)

Position level 2: S1CxG34(μm)

Position level 3: S1CxG35(μm)

Position level 4: S1CxG36(μm)

Position level 5: SICxG37 (μm)

Position level 6: SICxG38 (μm)

Position level 7: SICxG39 (μm)

Position level 8: SICxG40 (μm)

10. MT=Amount of the T axis rotation

The following tag can be added or omitted.

No	Tag	Explanation	Note
14	MT=Amount of the T axis rotation	Specifies the amount of the T axis rotation. The amount of the T axis rotation specifies the amount of movement of T axis by the number of rotations.	Amount of rotation: -32768 to 32767 Available only with the optional axis endless function. Refer to the axis endless function for details.

2.4 Move Instruction

11. MTE= Amount of the station axis rotation

The following tag can be added or omitted.

No	Tag	Explanation	Note
15	MTE= Amount of the station axis rotation	Specifies the amount of the station axis rotation. The operation of the station axis can be specified by the number of rotations.	Amount of rotation: -32768 to 32767 Available only with the optional axis endless function.

12. NWAIT/ENWAIT

Choose one of the tags from the following table.

No	Tag	Explanation	Note
16	NWAIT	Specifies the NWAIT instruction. The NWAIT instruction carries out the instructions excluding the move instruction from that step on, at the same time as the manipulator is carrying out that step.	
17	ENWAIT	Specifies the ENWAIT instruction. The ENWAIT instruction carries out the instructions excluding the move instructions from that step on, before reaching the next step.	Available only with the conditional NWAIT function (option: S2C576) Refer to ENWAIT of chapter 2.6 "Instruction Which Adheres to an Instruction" at page 2-219.

13. UNTIL/NSRCH

Choose one of the tags from the following table.

No	Tag	Explanation	Note
18	UNTIL	Specifies the UNTIL instruction. The UNTIL instruction is a tag instruction by which the condition of the input signal is evaluated during operation. When the condition of the input signal is full, the robot executes the next instruction.	Refer to UNTIL of chapter 2.6 "Instruction Which Adheres to an Instruction" at page 2-219.
19	NSRCH	Specifies the NSRCH instruction. The NSRCH instruction carries out the position detection without stopping the manipulator's motion.	Available only with the optional search-in-motion function.

14. ACC=Acceleration adjustment ratio

The following tag can be added or omitted.

No	Tag	Explanation	Note
20	ACC=Acceleration adjustment ratio	Specifies the acceleration adjustment ratio. The ACC instruction reduces the amount of acceleration in the specified ratio.	Acceleration adjustment ratio: 20% to 100% Variable B/B[]/LB/LB[]/I/I[]/LI/LI[]/D/D[]/LD/LD[] can be used.

2.4 Move Instruction

15. DEC=Deceleration adjustment ratio

The following tag can be added or omitted.

No	Tag	Explanation	Note
21	DEC=Deceleration adjustment ratio	Specifies the deceleration adjustment ratio. The DEC instruction reduces the amount of deceleration in the specified ratio.	Deceleration adjustment ratio: 20% to 100% Variable B/B[]/LB/LB[]/I/I[]/LI/LI[]/D/D[]/LD/LD[] can be used.



Acceleration adjustment ratio

The acceleration adjustment ratio (ACC) reduces the amount of acceleration in the specified ratio.

Using this function can reduce the load inertia on the tool and the workpiece.

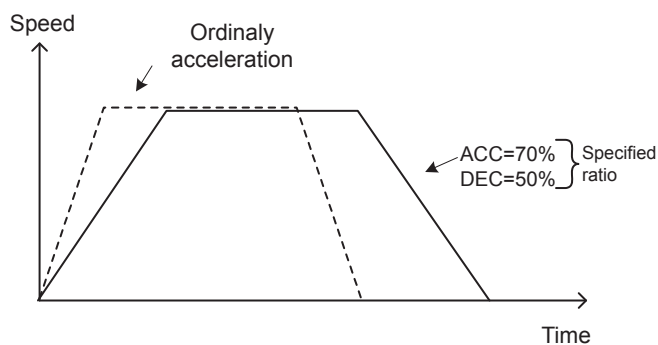

2.4 Move Instruction

16. +MOVJ/+MOVL/+MOVJ/+MOVJ

Choose one of the tags from the following table.

No	Tag	Explanation	Note
22	+MOVJ	Specifies the joint interpolation motion instruction on the master manipulator's side.	Available only with the optional coordinate function. Refer to the independent/coordinated function.
23	+MOVL	Specifies the linear interpolation motion instruction on the master manipulator's side.	Available only with the optional coordinate function. Refer to the independent/coordinated function.
24	+MOVJ	Specifies the circular interpolation motion instruction on the master manipulator's side.	Available only with the optional coordinate function. Refer to the independent/coordinated function.
25	+MOVJ	Specifies the spline interpolation motion instruction on the master manipulator's side.	Available only with the optional coordinate function. Refer to the independent/coordinated function.

Example

(1) MOVJ P000 VJ=50.00

Move from the manipulator's waiting position to step 1. Move by joint interpolation at a speed of 50%.

The position in Step 1 is registered to the P variable no. 0.

The path during movement is not specified. Be careful of interference.

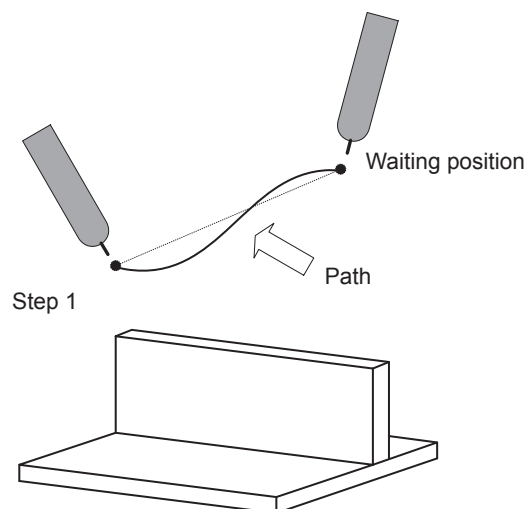

2.4 Move Instruction

MOVL

SUBSET	STANDARD	EXPANDED
Available	Available	Available

Function

Moves to the teaching position by linear interpolation.

Construction

The tag which can be used is limited by the type of the job.

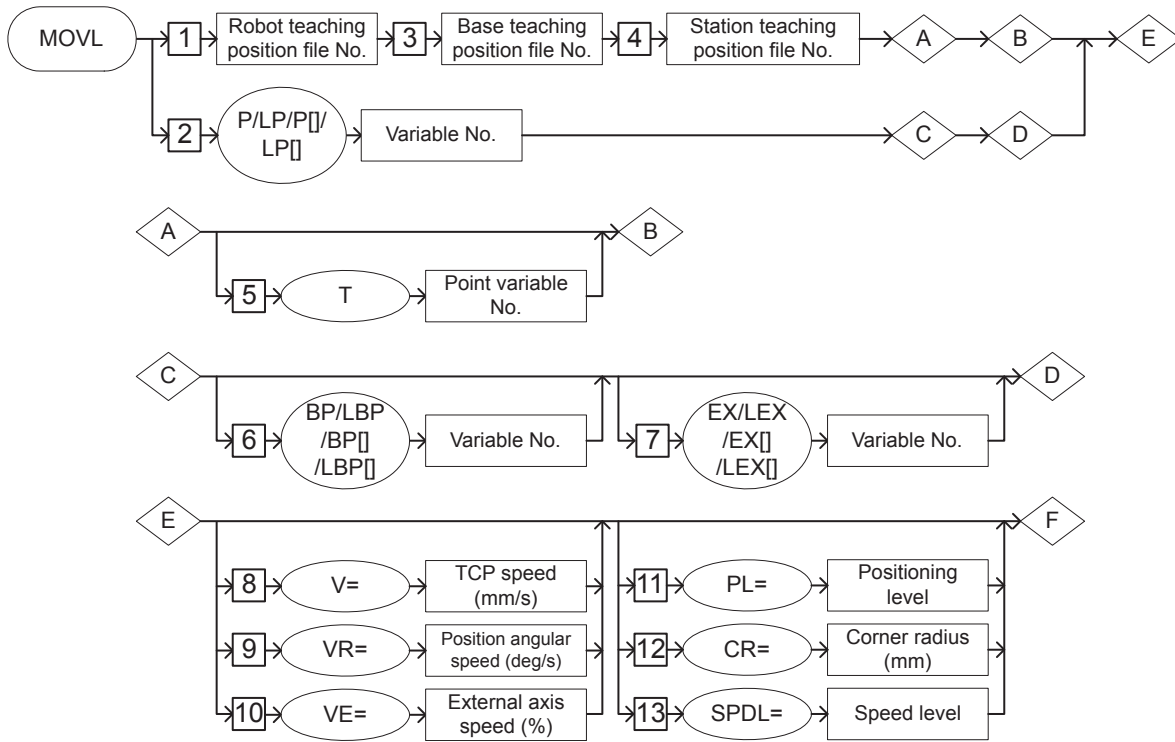

2.4 Move Instruction

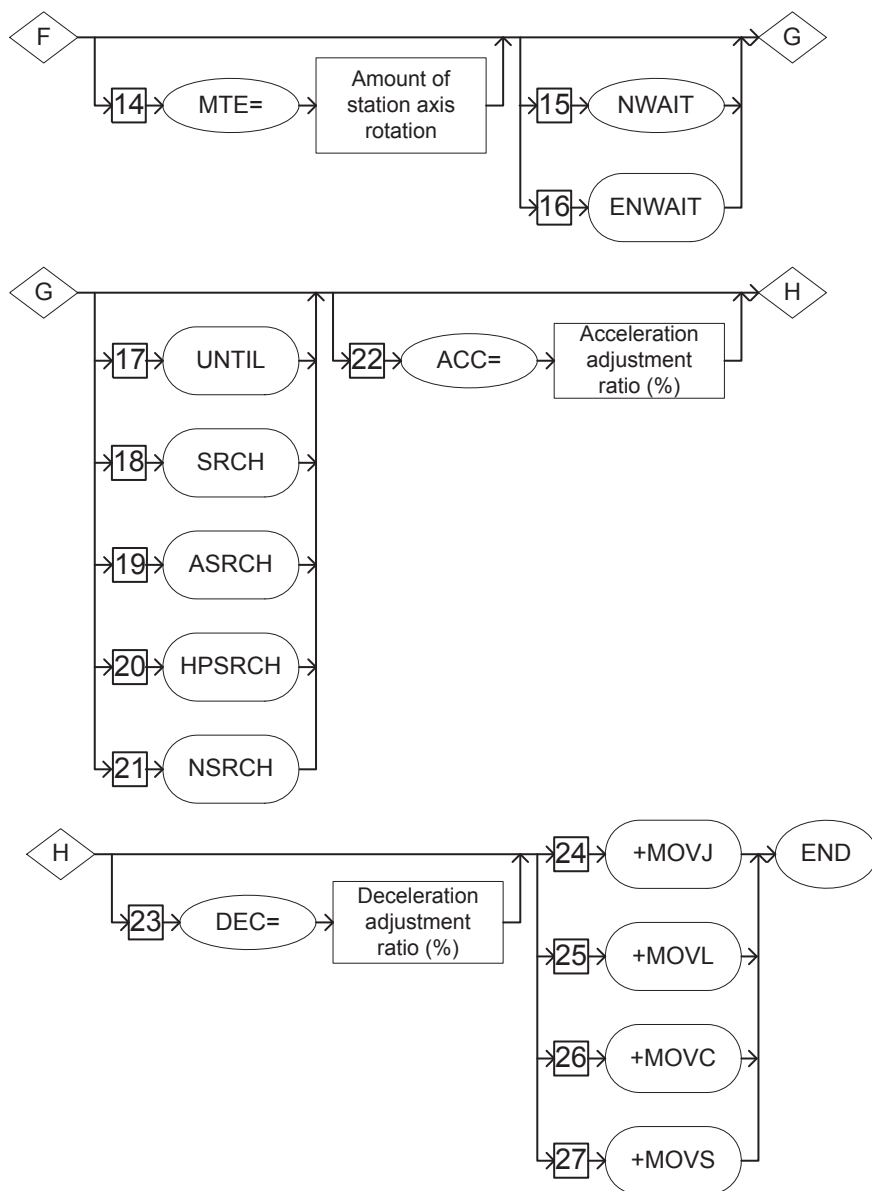

Table 2-3: Job Type and Control Group

No.	Job Type	Control Group	Remarks
1	Single	One manipulator (standard)	
2	Single	One manipulator with base axis	
3	Single	One manipulator with station axis	
4	Single	One manipulator with base and station axes	
5	Coordinated	Two manipulators	Optional
6	Coordinated	Two manipulators with base axis	Optional

2.4 Move Instruction

Table 2-4: Availability of Each Tag

No	Tag	Control Group						Note
		1	2	3	4	5	6	
1	Robot teaching position file number	●	●	●	●	●	●	
2	P/LP/P[]/LP[]	●	●	●	●	●	●	
3	Base axis teaching position file number	×	●	×	●	×	●	
4	Station teaching position file number	×	×	●	●	×	×	
5	T	○	○	○	○	○	○	Optional
6	BP/LBP/BP[]/LBP[]	×	●	×	●	×	●	
7	EX/LEX/EX[]/LEX[]	×	×	●	●	×	×	
8	V=	●	●	●	●	●	●	
9	VR=	●	●	●	●	●	●	
10	VE=	×	×	●	●	×	×	
11	PL=	●	●	●	●	●	●	
12	CR=	●	●	●	●	●	●	
13	SPDL=	○	○	○	○	○	○	Optional
14	MTE=	×	×	○	○	×	×	Optional
15	NWAIT	●	●	●	●	●	●	
16	ENWAIT	○	○	○	○	○	○	Optional
17	UNTIL	●	●	●	●	●	●	
18	SRCH	○	○	○	○	○	○	Optional
19	ASRCH	○	○	○	○	○	○	Optional
20	HPSRCH	○	○	○	○	○	○	Optional
21	NSRCH	○	○	○	○	○	○	Optional
22	ACC=	●	●	●	●	●	●	
23	DEC=	●	●	●	●	●	●	
24	+MOVJ	×	×	×	×	○	○	Optional
25	+MOVL	×	×	×	×	○	○	Optional
26	+MOVC	×	×	×	×	○	○	Optional
27	+MOVS	×	×	×	×	○	○	Optional

●: Available

○: Available only with optional function enabled

×: Not available

2.4 Move Instruction

Explanation

1. Robot teaching position file number /P Variable number /LP Variable number /P [Array number] /LP [Array number]

Choose one of the tags from the following table.

No	Tag	Explanation	Note
1	Robot teaching position file number	The robot axis teaching position in each step is written in this file unconditionally when the step is taught. This teaching position cannot be edited.	On the job display, this tag is not displayed.
2	P Variable number/ LP Variable number/ P [Array number]/ LP [Array number]	Specifies the position variable number of the robot axis. Moves to the position data set in the variable of the specified number.	Variable number: 000 to 127

2. Base Teaching Position File Number

When a robot teaching position file number is selected from the table in part 1 of this Explanation, add the following tag.

No	Tag	Explanation	Note
3	Base teaching position file number	The base axis teaching position in each step is written in this file unconditionally when the step is taught. This teaching position cannot be edited.	On the job display, this tag is not displayed.

3. Station Teaching Position File Number

When a robot teaching position file number is selected from the table in part 1 of this Explanation, add the following tag.

No	Tag	Explanation	Note
4	Station teaching position file number	The station axis teaching position in each step is written in this file unconditionally when the step is taught. This teaching position cannot be edited.	On the job display, this tag is not displayed.

4. T Point Variable number

When the robot teaching position file number is selected from the table in part 1 of this Explanation, the following can be added or omitted.

No	Tag	Explanation	Note
5	T Point Variable number	Specifies the point variable number. The point variable manages the teaching position registered in the job, and is used to move the manipulator to the same position several times in one job.	Available only with the optional point variable function.

DX100

2.4 Move Instruction

5. BP Variable number /LBP Variable number /BP
[Array number] /LBP [Array number]

When a P Variable number, LP Variable number, P [Array number], or LP [Array number] is selected from the table in part 1 of this Explanation, the following tag can be added.

No	Tag	Explanation	Note
6	BP Variable number/ LBP Variable number/ BP [Array number]/ LBP [Array number]	Specifies the position variable number of the base axis. Moves to the position data set in the variable of the specified number.	Variable number: 000 to 127

6. EX Variable number /LEX Variable number /EX
[Array number] /LEX [Array number]

When a P Variable number, LP Variable number, P [Array number], or LP [Array number] is selected from the table in part 1 of this Explanation, the following tag can be added.

No	Tag	Explanation	Note
7	EX Variable number/ LEX Variable number/ EX [Array number]/ LEX [Array number]	Specifies the position variable number of the station axis. Moves to the position data set in the variable of the specified number.	Variable number: 000 to 127

7. V=Tool center point speed /VR=Position angular
speed /VE=External axis speed

Choose one of the tags from the following table.

No	Tag	Explanation	Note
8	V=Tool center point speed	Specifies the tool center point speed. Specifies the unit of rate using the operation condition setting screen.	Variable B/B[]/LB/LB[]/I/ I[]/LI/LI[]/D/D[]/ LD/LD[] can be used. (Units: 0.1 mm/s)
9	VR=Position angular speed	Specifies the position angular speed.	Variable B/B[]/LB/LB[]/I/ I[]/LI/LI[]/D/D[]/ LD/LD[] can be used. (Units: 0.1 deg./s)
10	VE=External axis speed	Specifies the external axis speed.	Speed: 0.01% to 100.00% Variable B/B[]/LB/LB[]/I/ I[]/LI/LI[]/D/D[]/ LD/LD[] can be used. (Units: 0.01 %)

2.4 Move Instruction

8. PL=Position level /CR=Corner radius /SPDL=Speed level

Choose one of the tags from the following table.

No	Tag	Explanation	Note
11	PL=Position level	Specifies the position level. The position level is a level of the approach when the manipulator passes the position where the teaching procedure was performed.	Level: 0 to 8 Variable B/B[]/LB/LB[]/I/I[]/LI/LI[]/D/D[]/ LD/LD[] can be used.
12	CR=Corner radius	Specifies the corner radius. The manipulator operates by circular interpolation in which the corner radius is specified.	Radius: 0.1mm to 6553.5 mm Variable B/B[]/LB/LB[]/I/I[]/LI/LI[]/D/D[]/ LD/LD[] can be used. (Units: 0.1 mm)
13	SPDL=Speed level	Specifies the speed level. The speed level is the tag for the robot to end the execution of the move instruction in the state of the servo float control, and to confirm the state which has stopped. The operation ends when the speed feedback pulse of all axes goes below a constant value, and the manipulator is considered to have been stopped.	Level: Only 0 Available only with the optional servo-float function. Refer to the servo-float function for details.



Corner radius

The manipulator operates by circular interpolation in which the corner radius is specified.

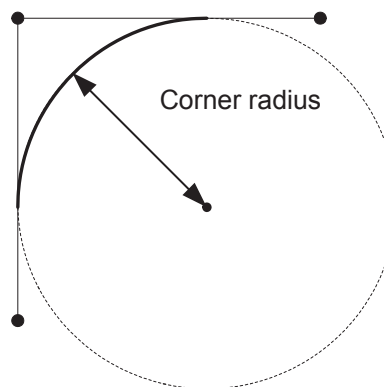

DX100

2.4 Move Instruction

9. MTE= Amount of station axis rotation

The following tag can be added or omitted.

No	Tag	Explanation	Note
14	MTE=Amount of station axis rotation	Specifies the amount of station axis rotation. The operation of the station axis can be specified by the number of rotations.	Amount of rotation: -32768 to 32767 Available only with the optional axis endless function. Refer to the axis endless function for details.

10. NWAIT/ENWAIT

The following tag can be added or omitted.

No	Tag	Explanation	Note
15	NWAIT	Specifies the NWAIT instruction. The NWAIT instruction carries out the instructions excluding the move instruction from that step on, at the same as time the manipulator is carrying out that step.	
16	ENWAIT	Specifies the ENWAIT instruction. The ENWAIT instruction carries out the instructions excluding the move instructions from that step on, before reaching the next step.	Available only with the conditional NWAIT function. (option: S2C576) Refer to ENWAIT of chapter 2.6 "Instruction Which Adheres to an Instruction" at page 2-219.

11. SRCH/UNTIL/ASRCH/HPSRCH/NSRCH

Choose one of the tags from the following table.

No	Tag	Explanation	Note
17	SRCH	Specifies the SRCH instruction. The SRCH instruction is a tag which detects the start point.	Available only with the optional start point searching function. Refer to chapter 2.6 "Instruction Which Adheres to an Instruction" at page 2-219.
18	UNTIL	Specifies the UNTIL instruction. The UNTIL instruction is a tag by which the conditions of the input signal are evaluated during operation. When the condition of the input signal is full, the robot executes the next instruction.	Refer to chapter 2.6 "Instruction Which Adheres to an Instruction" at page 2-219.

2.4 Move Instruction

No	Tag	Explanation	Note
19	ASRCH	Specifies the ASRCH instruction. The ASRCH instruction detects input signal's voltage.	Available only with the optional general-purpose sensor function. Refer to General-purpose Sensor function for details.
20	HPSRCH	Specifies the HPSRCH instruction. The HPSRCH instruction detects the position of the zero-point.	Available only with the optional zero-point position detection function. Refer to the Zero-point Position Detection function for details.
21	NSRCH	Specifies the NSRCH instruction. The NSRCH instruction detects a position without stopping the motion.	Available only with the optional search-in-motion function.

12. ACC=Acceleration adjustment ratio

The following tag can be added or omitted.

No	Tag	Explanation	Note
22	ACC=Acceleration adjustment ratio	Specifies the acceleration adjustment ratio. The ACC instruction reduces the amount of acceleration in the specified ratio.	Acceleration adjustment ratio: 20% to 100% Variable B/B[]/LB/LB[]/I/I[]/LI/LI[]/D/D[]/ LD/LD[] can be used.

13. DEC=Deceleration adjustment ratio

The following tag can be added or omitted.

No	Tag	Explanation	Note
23	DEC=Deceleration adjustment ratio	Specifies the deceleration adjustment ratio. The DEC instruction reduces the amount of deceleration in the specified ratio.	Deceleration adjustment ratio: 20% to 100% Variable B/B[]/LB/LB[]/I/I[]/LI/LI[]/D/D[]/ LD/LD[] can be used.

DX100

2.4 Move Instruction

14. +MOVJ/+MOVL/+MOVC/+MOVS

Choose one of the tags from the following table.

No	Tag	Explanation	Note
24	+MOVJ	Specifies the joint interpolation motion instruction on the master manipulator's side.	Available only with the optional coordinate function. Refer to the independent/coordinated function.
25	+MOVL	Specifies the linear interpolation motion instruction on the master manipulator's side.	Available only with the optional coordinate function. Refer to the independent/coordinated function.
26	+MOVC	Specifies the circular interpolation motion instruction on the master manipulator's side.	Available only with the optional coordinate function. Refer to the independent/coordinated function.
27	+MOVS	Specifies the spline interpolation motion instruction on the master manipulator's side.	Available only with the optional coordinate function. Refer to the independent/coordinated function.

Example

- (1) NOP
 MOVJ VJ=50.00
 MOVJ VJ=25.00
 MOVJ VJ=12.50 *** Step 3
 MOVL V=138 *** Step 4
 Moves from Step 3 to Step 4 by the linear interpolation at a rate of 138cm/min.

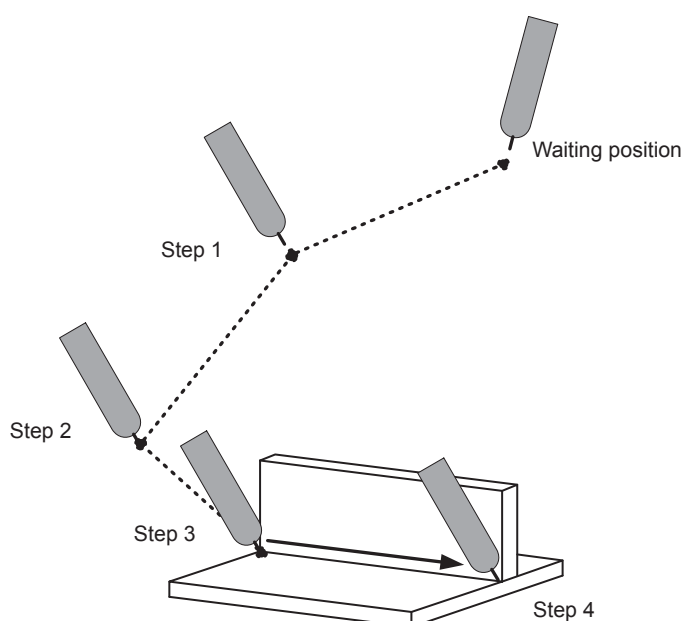

MOVC

SUBSET	STANDARD	EXPANDED
Available	Available	Available

Function

Moves to the teaching position by circular interpolation.

Construction

The tag which can be used is limited by the type of the job.

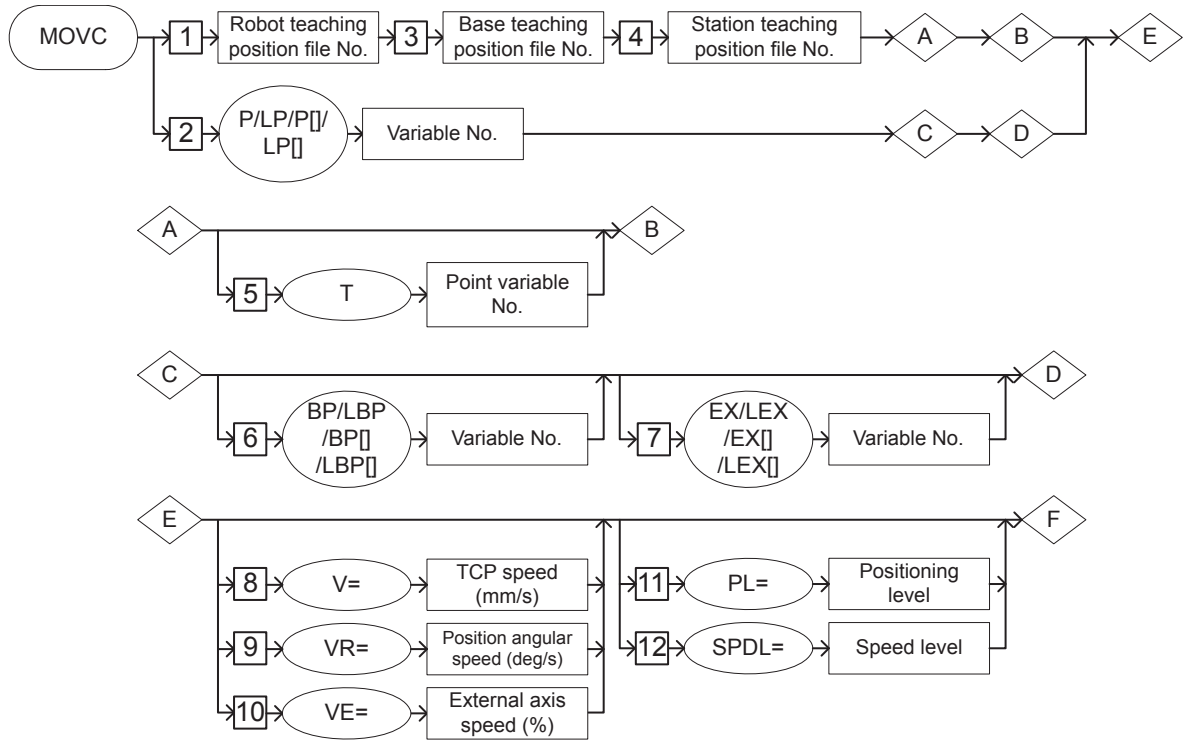

2.4 Move Instruction

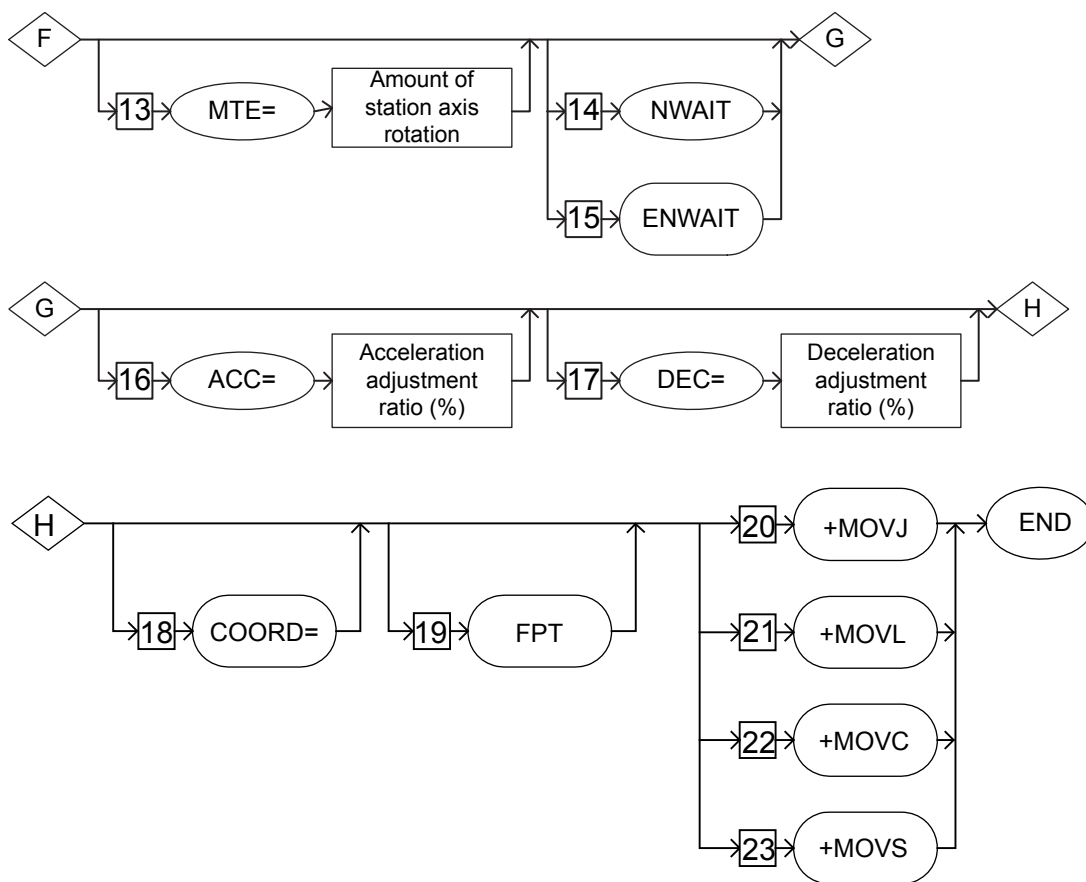

Table 2-5: Job Type and Control Group

No.	Job Type	Control Group	Remarks
1	Single	One manipulator (standard)	
2	Single	One manipulator with base axis	
3	Single	One manipulator with station axis	
4	Single	One manipulator with base and station axes	
5	Coordinated	Two manipulators	Optional
6	Coordinated	Two manipulators with base axis	Optional

2.4 Move Instruction

Table 2-6: Availability of Each Tag

No	Tag	Control Group						Note
		1	2	3	4	5	6	
1	Robot teaching position file number	●	●	●	●	●	●	
2	P/LP/P[]/LP[]	●	●	●	●	●	●	
3	Base teaching position file number	×	●	×	●	×	●	
4	Station teaching position file number	×	×	●	●	×	×	
5	T	○	○	○	○	○	○	Optional
6	BP/LBP/BP[]/LBP[]	×	●	×	●	×	●	
7	EX/LEX/EX[]/LEX[]	×	×	●	●	×	×	
8	V=	●	●	●	●	●	●	
9	VR=	●	●	●	●	●	●	
10	VE=	×	×	●	●	×	×	
11	PL=	●	●	●	●	●	●	
12	SPDL=	○	○	○	○	○	○	Optional
13	MTE=	×	×	○	○	×	×	Optional
14	NWAIT	●	●	●	●	●	●	
15	ENWAIT	○	○	○	○	○	○	Optional
16	ACC=	●	●	●	●	●	●	
17	DEC=	●	●	●	●	●	●	
18	COORD=	●	●	●	●	●	●	
19	FPT	●	●	●	●	●	●	
20	+MOVJ	×	×	×	×	○	○	Optional
21	+MOVL	×	×	×	×	○	○	Optional
22	+MOVC	×	×	×	×	○	○	Optional
23	+MOVS	×	×	×	×	○	○	Optional

●: Available

○: Available only with optional function enabled

×: Not available

2.4 Move Instruction

Example

1. Robot teaching position file number /P Variable number /LP Variable number /P [Array number] /LP [Array number]

Choose one of the tags from the following table.

No	Tag	Explanation	Note
1	Robot teaching position file number	The robot axis teaching position in each step is written in this file unconditionally when the step is taught. This teaching position cannot be edited.	On the job display, this tag is not displayed.
2	P Variable number/ LP Variable number/ P [Array number]/ LP [Array number]	Specifies the position variable number of the robot axis. Moves to the position data set in the variable of the specified number.	Variable number: 000 to 127

2. Base Teaching Position File Number

When a base teaching position file number is selected from the table in part 1 of this Explanation, added the following tag.

No	Tag	Explanation	Note
3	Base teaching position file number	The base axis teaching position in each step is written in this file unconditionally when the step is taught. This teaching position cannot be edited.	On the job display, this tag is not displayed.

3. Station Teaching Position File Number

When a base teaching position file number is selected from the table in part 1 of this Explanation, added the following tag.

No	Tag	Explanation	Note
4	Station teaching position file number	The station axis teaching position in each step is written in this file unconditionally when the step is taught. This teaching position cannot be edited.	On the job display, this tag is not displayed.

4. T Point Variable number

When the robot teaching position file number is selected from the table in part 1 of this Explanation, the following tag can be added or omitted.

No	Tag	Explanation	Note
5	T Point Variable number	Specifies the point variable number. The point variable manages the teaching position registered in the job, and is used to move the manipulator to the same position several times in one job.	Available only with the optional point variable function.

2.4 Move Instruction

5. BP Variable number /LBP Variable number /BP
[Array number] /LBP [Array number]

When a P Variable number, LP Variable number, P [Array number], or LP [Array number] is selected from the table in part 1 of this Explanation, the following tag can be added.

No	Tag	Explanation	Note
6	BP Variable number/ LBP Variable number/ BP [Array number]/ LBP [Array number]	Specifies the position variable number of the base axis. Moves to the position data set in the variable of the specified number.	Variable number: 000 to 127

6. EX Variable number /LEX Variable number /EX
[Array number] /LEX [Array number]

When a P Variable number, LP Variable number, P [Array number], or LP [Array number] is selected from the table in part 1 of this Explanation, the following tag can be added.

No	Tag	Explanation	Note
7	EX Variable number/ LEX Variable number/ EX [Array number]/ LEX [Array number]	Specifies the position variable number of the station axis. Moves to the position data set in the variable of the specified number.	Variable number: 000 to 127

7. V=Tool center point speed /VR=Position angular
speed /VE=External axis speed

Choose one of the tags from the following table.

No	Tag	Explanation	Note
8	V=Tool center point speed	Specifies the tool center point speed. Specifies the unit of rate using the operation condition setting screen.	Variable B/B[]/LB/LB[]/I/ I[]/LI/LI[]/D/D[]/ LD/LD[] can be used. (Units: 0.1 mm/s)
9	VR=Position angular speed	Specifies the position angular speed.	Variable B/B[]/LB/LB[]/I/ I[]/LI/LI[]/D/D[]/ LD/LD[] can be used. (Units: 0.1 deg/s)
10	VE=External axis speed	Specifies the external axis speed.	Speed: 0.01% to 100.00% Variable B/B[]/LB/LB[]/I/ I[]/LI/LI[]/D/D[]/ LD/LD[] can be used.(Units: 0.01 %)

DX100

2.4 Move Instruction

8. PL=Position level /SPDL=Speed level

Choose one of the tags from the following table.

No	Tag	Explanation	Note
11	PL=Position level	Specifies the position level. The position level is a level of the approach when the manipulator passes the position where the teaching procedure was performed.	Level: 0 to 8 Variable B/B[]/LB/LB[]//I[]/LI/LI[]/D/D[]/ LD/LD[] can be used.
12	SPDL=Speed level	Specifies the speed level. The speed level is a tag for the robot to end the execution of the move instruction in the state of servo float control, and to confirm the state which has stopped. The operation ends when the speed feedback pulse of all axes goes below a constant value, and the manipulator is considered to have been stopped.	Level: Only 0 Available only with the optional servo-float function.

9. MTE=Amount of station axis rotation

The following tag can be added or omitted.

No	Tag	Explanation	Note
13	MTE=Amount of station axis rotation	Specifies the amount of station axis rotation. The operation of the station axis can be specified by the number of rotations.	Amount of rotation: -100 to 100 Available only with the optional axis endless function.

10. NWAIT/ENWAIT

The following tag can be added or omitted.

No	Tag	Explanation	Note
14	NWAIT	Specifies the NWAIT instruction. The NWAIT instruction carries out the instructions excluding the move instruction from that step on, at the same time as the manipulator is carrying out that step.	
15	ENWAIT	Specifies the ENWAIT instruction. The ENWAIT instruction carries out the instructions excluding the move instructions from that step on, before reaching the next step.	Available only with the conditional NWAIT function. (option: S2C576) Refer to ENWAIT of chapter 2.6 "Instruction Which Adheres to an Instruction" at page 2-219.

2.4 Move Instruction

11. ACC=Acceleration adjustment ratio

The following tag can be added or omitted.

No	Tag	Explanation	Note
16	ACC=Acceleration adjustment ratio	Specifies the acceleration adjustment ratio. The ACC instruction reduces the amount of acceleration in the specified ratio.	Acceleration adjustment ratio: 20% to 100% Variable B/B[]/LB/LB[]/I/I[]/L/LI[]/D/D[]/LD/LD[] can be used.

12. DEC=Deceleration adjustment ratio

The following tag can be added or omitted.

No	Tag	Explanation	Note
17	DEC=Deceleration adjustment ratio	Specifies the deceleration adjustment ratio. The DEC instruction reduces the amount of deceleration in the specified ratio.	Deceleration adjustment ratio: 20% to 100% Variable B/B[]/LB/LB[]/I/I[]/L/LI[]/D/D[]/LD/LD[] can be used.

2.4 Move Instruction

13. COORD=Arc attitude control specification

The following tag can be added or omitted.

No	Tag	Explanation	Note
18	COORD=Arc attitude control specification	Specifies the attitude control of arc. This is not usually needed, but depending on teaching, the intended circular motion may not be performed. In this case, specify as follows. When the circular surface is parallel with the robot installation surface, specify as COORD = 0. When the circular surface is not parallel with the robot installation surface, specify as COORD = 1.	

Example

```

NOP
MOVL V=138
MOVC V=138 COORD=1      ***Step 2
MOVC V=138 COORD=1      ***Step 3
MOVC V=138 COORD=1      ***Step 4
MOVL V=138
MOVC V=138 COORD=0      ***Step 6
MOVC V=138 COORD=0      ***Step 7
MOVC V=138 COORD=0      ***Step 8
MOVL V=138
END

```

Step 2 to 4 performs the attitude control based on the circular surface.

Step 6 to 7 performs the attitude control based on the robot installation surface.

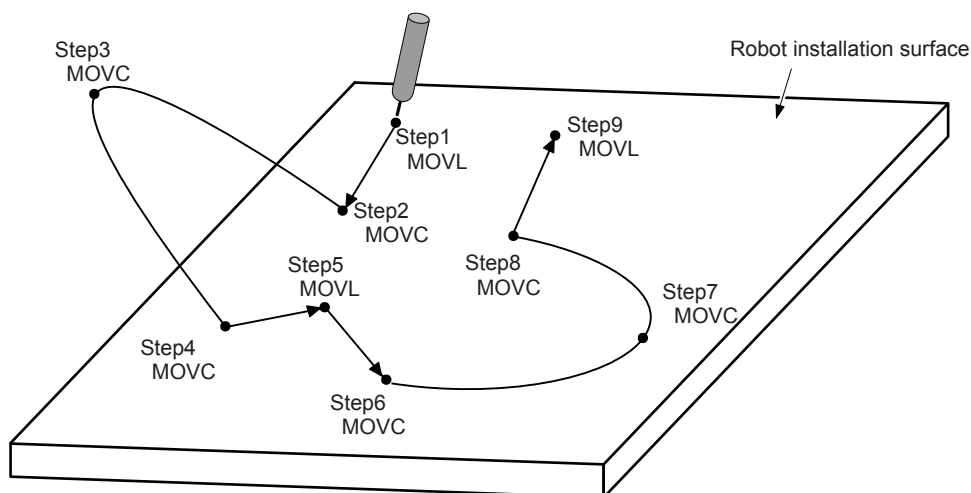

2.4 Move Instruction

14. FPT=Arc end-point setting

The following tag can be added or omitted.

No	Tag	Explanation	Note
22	FPT=Arc end-point setting	Specifies the end-point of the arc (the point at which the curvature of the arc is to be changed).	

Example

(1) NOP

```

MOVL V=138
MOVC V=138      ***Step 2
MOVC V=138      ***Step 3
MOVC V=138      ***Step 4
MOVC FPT V=138  ***Step 5
MOVC V=138      ***Step 6
MOVC V=138      ***Step 7
MOVL V=138
END

```

Moves from Step 2 to Step 7 by circular interpolation at a rate of 138 cm/min.

Moves to Step 3 in a circular arc formed with the teaching points in Steps 2, 3, and 4.

Moves to Step 4 in a circular arc formed with the teaching points in Steps 3, 4, and 5.

Moves to Step 5 in a circular arc formed with the teaching points in Steps 3, 4, and 5.

Moves to Step 6 in a circular arc formed with the teaching points in Steps 5, 6, and 7.

Moves to Step 7 in a circular arc formed with the teaching points in Steps 5, 6, and 7.

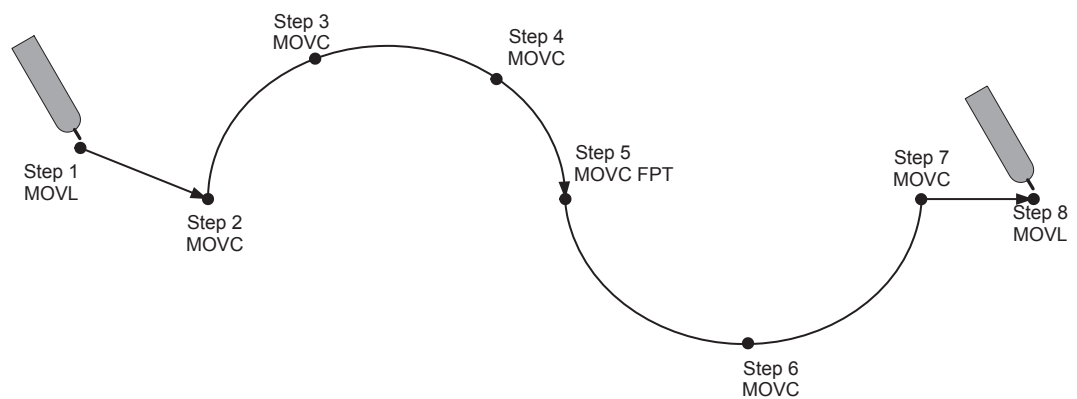

DX100

2.4 Move Instruction

15. +MOVJ/+MOVL/+MOVJ/+MOVJ

Choose one of the tags from the following table.

No	Tag	Explanation	Note
18	+MOVJ	Specifies the joint interpolation motion instruction on the master manipulator's side.	Available only with the optional coordinate function. Refer to the independent/coordinated function.
19	+MOVL	Specifies the linear interpolation motion instruction on the master manipulator's side.	Available only with the optional coordinate function. Refer to the independent/coordinated function.
20	+MOVJ	Specifies the circular interpolation motion instruction on the master manipulator's side.	Available only with the optional coordinate function. Refer to the independent/coordinated function.
21	+MOVJ	Specifies the spline interpolation motion instruction on the master manipulator's side.	Available only with the optional coordinate function. Refer to the independent/coordinated function.

MOVS

SUBSET	STANDARD	EXPANDED
Available	Available	Available

Function

Moves to the teaching position by spline interpolation.

Construction

The tag which can be used is limited by the type of the job.

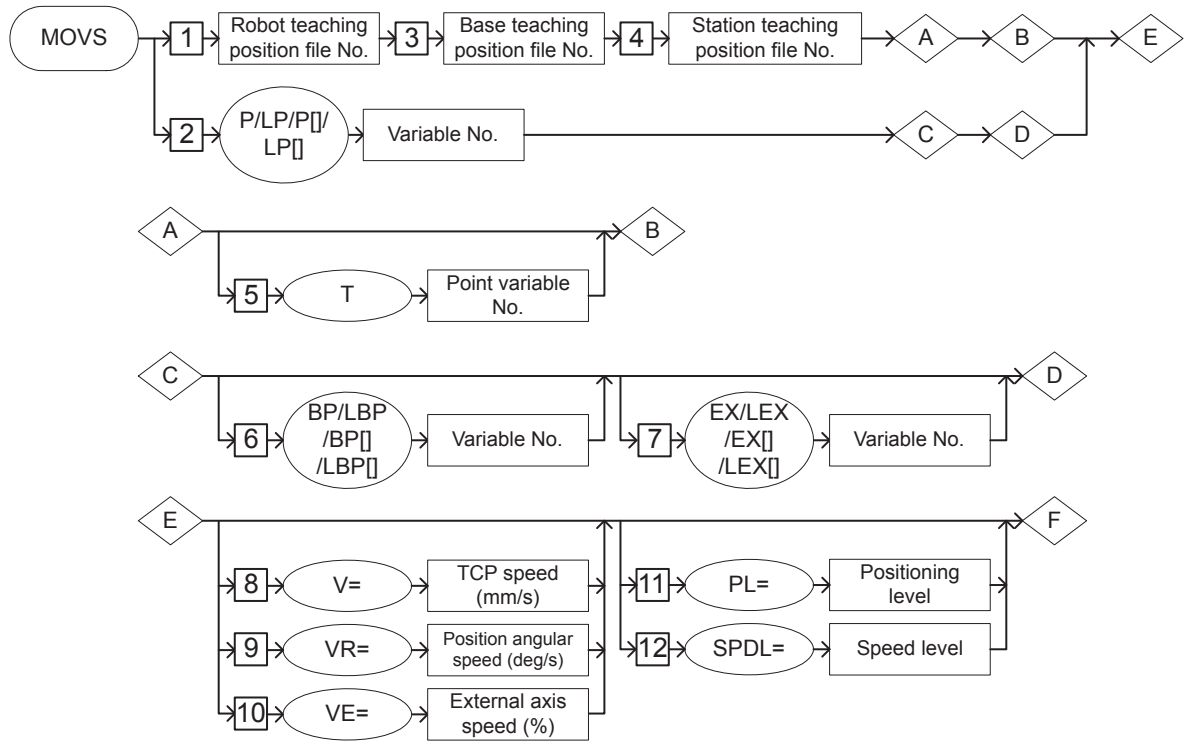

2.4 Move Instruction

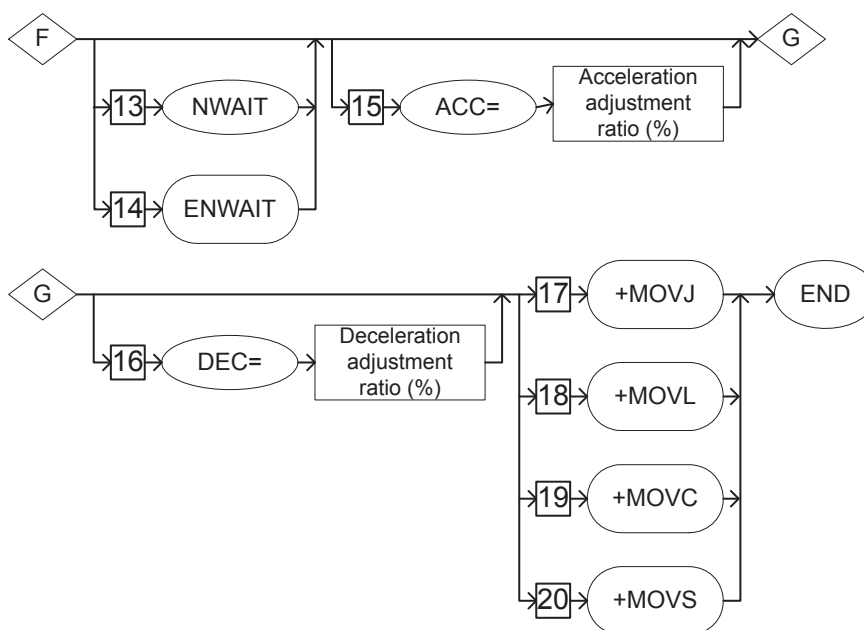

Table 2-7: Job Type and Control Group

No.	Job type	Control Group	Remarks
1	Single	One manipulator (standard)	
2	Single	One manipulator with base axis	
3	Single	One manipulator with station axis	
4	Single	One manipulator with base and station axes	
5	Coordinated	Two manipulators	Optional
6	Coordinated	Two manipulators with base axis	Optional

2.4 Move Instruction

Table 2-8: Availability of Each Tag

No	Tag	Control Group						Note
		1	2	3	4	5	6	
1	Robot teaching position file number	●	●	●	●	●	●	
2	P/LP/P[]/LP[]	●	●	●	●	●	●	
3	Base teaching position file number	×	●	×	●	×	●	
4	Station teaching position file number	×	×	●	●	×	×	
5	T	○	○	○	○	○	○	Optional
6	BP/LBP/BP[]/LBP[]	×	●	×	●	×	●	
7	EX/LEX/EX[]/LEX[]	×	×	●	●	×	×	
8	V=	●	●	●	●	●	●	
9	VR=	●	●	●	●	●	●	
10	VE=	×	×	●	●	×	×	
11	PL=	●	●	●	●	●	●	
12	SPDL=	○	○	○	○	○	○	Optional
14	NWAIT	●	●	●	●	●	●	
15	ENWAIT	○	○	○	○	○	○	Optional
16	ACC=	●	●	●	●	●	●	
17	DEC=	●	●	●	●	●	●	
18	+MOVJ	×	×	×	×	○	○	Optional
19	+MOVL	×	×	×	×	○	○	Optional
20	+MOV C	×	×	×	×	○	○	Optional
21	+MOV S	×	×	×	×	○	○	Optional

●: Available

○: Available only with optional function enabled

×: Not available

Explanation

1. Robot teaching position file number /P Variable number /LP Variable number /P [Array number] /LP [Array number]

Choose one of the tags from the following table.

No	Tag	Explanation	Note
1	Robot teaching position file number	The robot axis teaching position in each step is written in this file unconditionally when the step is taught. This teaching position cannot be edited.	On the job display, this tag is not displayed.
2	P Variable number / LP Variable number / P [Array number] / LP [Array number]	Specifies the position variable number of the robot axis. Moves to the position data set in the variable of the specified number.	Variable number: 000 to 127

DX100

2.4 Move Instruction

2. Base Teaching Position File Number

When a robot teaching position file number is selected from the table in part 1 of this Explanation, add the following tag.

No	Tag	Explanation	Note
3	Base teaching position file number	The base axis teaching position in each step is written in this file unconditionally when the step is taught. This teaching position cannot be edited.	On the job display, this tag is not displayed.

3. Station Teaching Position File Number

When a robot teaching position file number is selected from the table in part 1 of this Explanation, add the following tag.

No	Tag	Explanation	Note
4	Station teaching position file number	The station axis teaching position in each step is written in this file unconditionally when the step is taught. This teaching position cannot be edited.	On the job display, this tag is not displayed.

4. T Point Variable number

When the robot teaching position file number is selected from the table in part 1 of this Explanation, the following tag can be added or omitted.

No	Tag	Explanation	Note
5	T Point Variable number	Specifies the point variable number. The point variable manages the teaching position registered in the job, and is used to move the manipulator to the same position several times in one job.	Available only with the optional point variable function.

5. BP Variable number /LBP Variable number /BP [Array number] /LBP [Array number]

When a P Variable number, LP Variable number, P [Array number], or LP [Array number] is selected from the table in part 1 of this Explanation, the following tag can be added.

No	Tag	Explanation	Note
6	BP Variable number / LBP Variable number / BP [Array number]/ LBP [Array number]	Specifies the position variable number of the base axis. Moves to the position data set in the variable of the specified number.	Variable number: 000 to 127

2.4 Move Instruction

6. EX Variable number /LEX Variable number /EX
[Array number] /LEX [Array number]

When a P Variable number, LP Variable number, P [Array number], or LP [Array number] is selected from the table in part 1 of this Explanation, the following tag can be added.

No	Tag	Explanation	Note
7	EX Variable number / LEX Variable number / EX [Array number]/ LEX [Array number]	Specifies the position variable number of the station axis. Moves to the position data set in the variable of the specified number.	Variable number: 000 to 127

7. V=Tool center point speed /VR=Position angular
speed /VE=External axis speed

Choose one of the tags from the following table.

No	Tag	Explanation	Note
8	V=Tool center point speed	Specifies the tool center point speed. Specifies the unit of rate using the operation condition setting screen.	Variable B/B[]/LB/LB[]/I/ I[]/L/LI[]/D/D[]/ LD/LD[] can be used. (Units: 0.1 mm/s)
9	VR=Position angular speed	Specifies the position angular speed.	Variable B/B[]/LB/LB[]/I/ I[]/L/LI[]/D/D[]/ LD/LD[] can be used. (Units: 0.1 deg/s)
10	VE=External axis speed	Specifies the external axis speed.	Speed: 0.01% to 100.00% Variable B/B[]/LB/LB[]/I/ I[]/L/LI[]/D/D[]/ LD/LD[] can be used. (Units: 0.01 %)

8. PL=Position level /SPDL=Speed level

Choose one of the tags from the following table.

No	Tag	Explanation	Note
11	PL=Position level	Specifies the position level. The position level is a level of the approach when the manipulator passes the position where the teaching procedure was done.	Level: 0 to 8 Variable B/B[]/LB/LB[]/I/ I[]/L/LI[]/D/D[]/ LD/LD[] can be used.
12	SPDL=Speed level	Specifies the speed level. The speed level is a tag for the robot to end the execution of the move instruction in the state of servo float control, and to confirm the state which has stopped. The operation ends when the speed feedback pulse of all axes goes below a constant value, and the manipulator is considered to have been stopped.	Level: Only 0 Available only with the optional servo-float function.

DX100

2.4 Move Instruction

9. NWAIT/ENWAIT

The following tag can be added or omitted.

No	Tag	Explanation	Note
13	NWAIT	Specifies the NWAIT instruction. The NWAIT instruction carries out the instructions excluding the move instruction from that step on, at the same time as the manipulator is carrying out that step.	
14	ENWAIT	Specifies the ENWAIT instruction. The ENWAIT instruction carries out the instructions excluding the move instructions from that step on, before reaching the next step.	Available only with the conditional NWAIT function. (option: S2C576) Refer to ENWAIT of chapter 2.6 "Instruction Which Adheres to an Instruction" at page 2-219.

10. ACC=Acceleration adjustment ratio

The following tag can be added or omitted.

No	Tag	Explanation	Note
15	ACC=Acceleration adjustment ratio	Specifies the acceleration adjustment ratio. The ACC instruction reduces the amount of acceleration in the specified ratio.	Acceleration adjustment ratio: 20% to 100% Variable B/B[]/LB/LB[]/I/I[]/L/LI[]/D/D[]/LD/LD[] can be used.

11. DEC=Deceleration adjustment ratio

The following tag can be added or omitted.

No	Tag	Explanation	Note
16	DEC=Deceleration adjustment ratio	Specifies the deceleration adjustment ratio. The DEC instruction reduces the amount of deceleration in the specified ratio.	Deceleration adjustment ratio: 20% to 100% Variable B/B[]/LB/LB[]/I/I[]/L/LI[]/D/D[]/LD/LD[] can be used.

2.4 Move Instruction

12. +MOVJ/+MOVL/+MOVJ/+MOVJ

Choose one of the tags from the following table.

No	Tag	Explanation	Note
17	+MOVJ	Specifies the joint interpolation motion instruction on the master manipulator's side.	Available only with the optional coordinate function. Refer to the independent/coordinated function.
18	+MOVL	Specifies the linear interpolation motion instruction on the master manipulator's side.	Available only with the optional coordinate function. Refer to the independent/coordinated function.
19	+MOVJ	Specifies the circular interpolation motion instruction on the master manipulator's side.	Available only with the optional coordinate function. Refer to the independent/coordinated function.
20	+MOVJ	Specifies the spline interpolation motion instruction on the master manipulator's side.	Available only with the optional coordinate function. Refer to the independent/coordinated function.

Example

(1) NOP

```

MOVJ V=138
MOVJ V=138 *** Step 2
MOVJ V=138 *** Step 3
MOVJ V=138 *** Step 4
MOVJ V=138 *** Step 5
MOVJ V=138 *** Step 6
MOVJ V=138
END

```

Moves from Step 2 to Step 6 by spline interpolation at a rate of 138cm/min.

Moves to Step 3 by spline interpolation defined by the teaching points in Steps 2, 3, and 4.

Moves to Step 4 by synchronized spline interpolation defined by the teaching points in Steps 2, 3, 4 and by the synchronized spline interpolation defined by the teaching points in Steps 3, 4, and 5.

Moves to Step 5 by synchronized spline interpolation defined by the teaching points in Steps 3, 4,5 and by synchronized spline interpolation defined by the teaching points in Steps 4, 5, and 6.

Moves to Step 6 by spline interpolation defined by the teaching points in Steps 4, 5, and 6.

2.4 Move Instruction

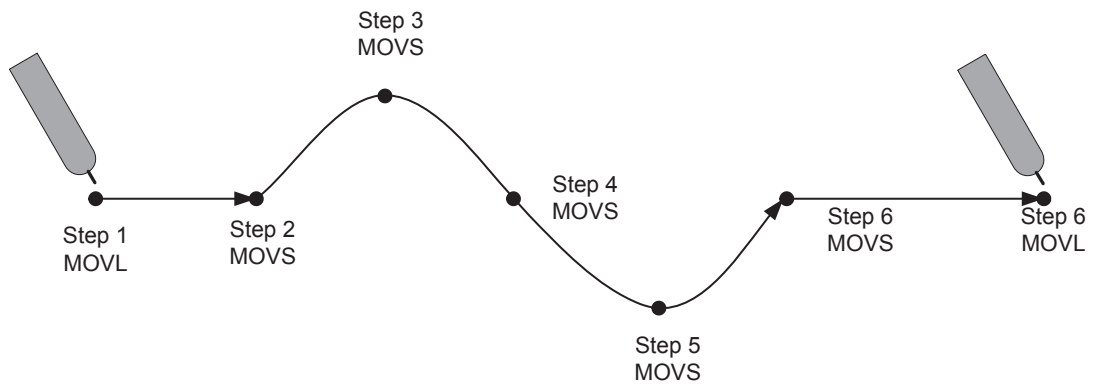

IMOV

SUBSET	STANDARD	EXPANDED
Available	Available	Available

Function

Moves by linear interpolation from the current position for the specified incremental value.

Construction

The tag which can be used is limited by the type of the job.

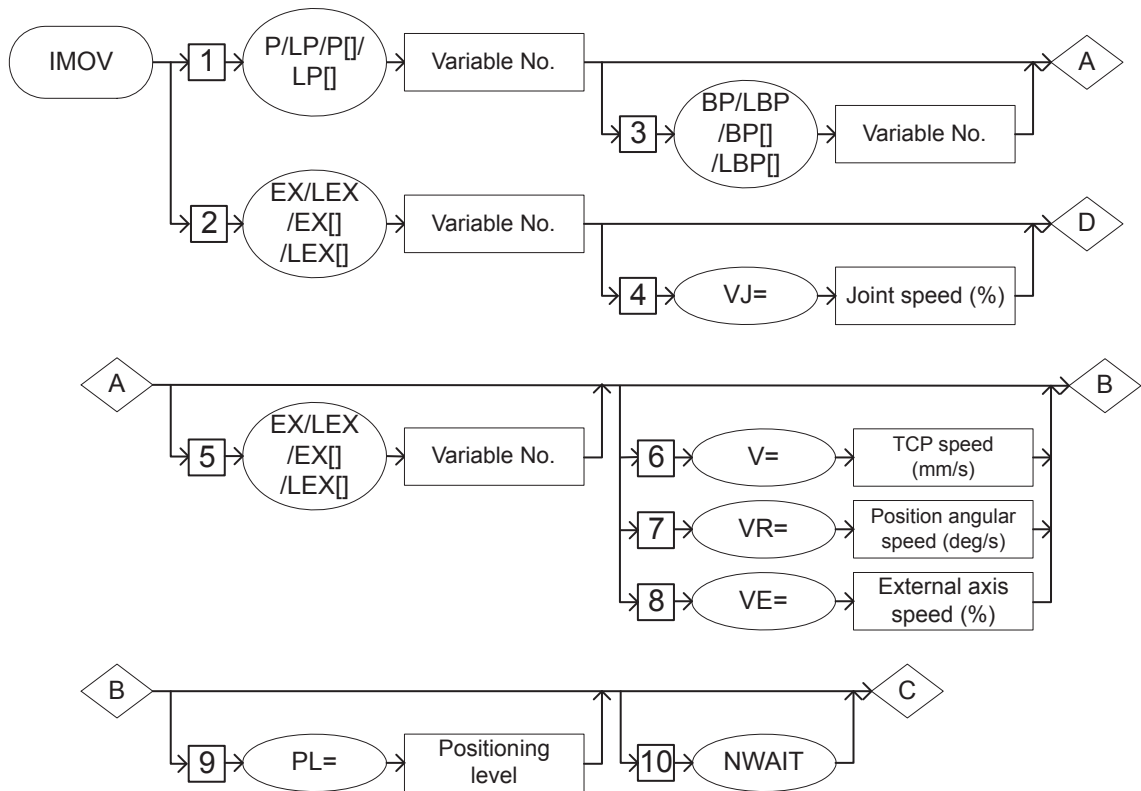

2.4 Move Instruction

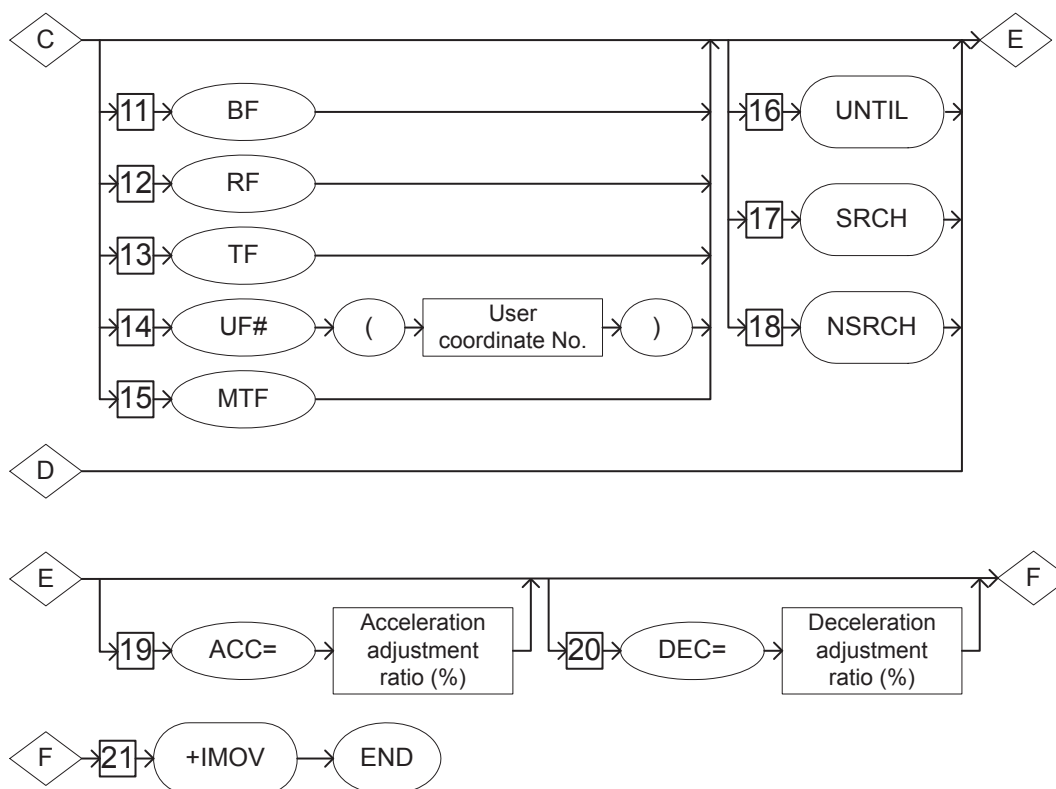

Table 2-9: Job Type and Control Group

No.	Job Type	Control Group	Remarks
1	Single	One manipulator (standard)	
2	Single	One manipulator with base axis	
3	Single	One manipulator with station axis	
4	Single	One manipulator with base and station axes	
5	Single	Only station axis	
6	Coordinated	Two manipulators	Optional
7	Coordinated	Two manipulators with base axis	Optional

2.4 Move Instruction

Table 2-10: Availability of Each Tag

No	Tag	Control Group							Note
		1	2	3	4	5	6	7	
1	P/LP/P[]/LP[]	●	●	●	●	×	●	●	
2	EX/LEX/EX[]/LEX[]	×	×	×	×	●	×	×	
3	BP/LBP/BP[]/LBP[]	×	●	×	●	×	●	×	
4	VJ=	×	×	×	×	●	×	×	
5	EX/LEX/EX[]/LEX[]	×	×	●	●	×	×	×	
6	V=	●	●	●	●	×	●	●	
7	VR=	●	●	●	●	×	●	●	
8	VE=	×	×	●	●	×	×	×	
9	PL=	●	●	●	●	×	●	●	
10	NWAIT	●	●	●	●	×	●	●	
11	BF	●	●	●	●	×	●	●	
12	RF	●	●	●	●	×	●	●	
13	TF	●	●	●	●	×	●	●	
14	UF#()	●	●	●	●	×	●	●	
15	MTF	×	×	×	×	×	●	●	
16	UNTIL	●	●	●	●	×	●	●	
17	SRCH	○	○	○	○	×	○	○	Optional
18	NSRCH	○	○	○	○	×	○	○	Optional
19	ACC=	●	●	●	●	●	●	●	
20	DEC=	●	●	●	●	●	●	●	
21	+IMOV	×	×	×	×	×	○	○	Optional

●: Available

○: Available only with optional function enabled

×: Not available

Explanation

1. P Variable number /LP Variable number /P [Array number] /LP [Array number] /EX Variable number / LEX Variable number /EX [Array number] /LEX [Array number]

Choose one of the tags from the following table.

No	Tag	Explanation	Note
1	P Variable number / LP Variable number / P [Array number]/ LP [Array number]	Specifies the position variable number of the manipulator axis. Moves the axis according to the position data set in the specified variable number.	Variable number: 000 to 127
2	EX Variable number / LEX Variable number / EX [Array number]/ LEX [Array number]	Specifies the position variable number of the station axis. Moves the axis according to the position data set in the specified variable number.	Variable number: 000 to 127

DX100

2.4 Move Instruction

2. BP Variable number /LBP Variable number /BP
[Array number] /LBP [Array number]

When a P Variable number, LP Variable number, P [Array number], or LP [Array number] is selected from the table in part 1 of this Explanation, the following tag can be added.

No	Tag	Explanation	Note
3	BP Variable number / LBP Variable number / BP [Array number]/ LBP [Array number]	Specifies the position variable number of the base axis. Moves the axis according to the position data set in the specified variable number.	Variable number: 000 to 127

3. VJ=Joint speed

The following tag can be added or omitted.

No	Tag	Explanation	Note
4	VJ=Joint speed	Specifies the joint speed. The joint speed in a ratio to the highest speed. Operates at the speed decided beforehand when the joint speed is omitted.	Speed: 0.01% to 100.00% Variable B/B[]/LB/LB[]// I[]/LI/LI[]/D/D[]/ LD/LD[] can be used. (Units: 0.01 %)

4. EX Variable number /LEX Variable number /EX
[Array number] /LEX [Array number]

When a P Variable number, LP Variable number, P [Array number], or LP [Array number] is selected from the table in part 1 of this Explanation, the following tag can be added.

No	Tag	Explanation	Note
5	EX Variable number / LEX Variable number / EX [Array number]/ LEX [Array number]	Specifies the position variable number of the station axis. Moves the axis according to the position data set in the specified variable number.	Variable number: 000 to 127

2.4 Move Instruction

5. V=Tool center point speed /VR=Position angular speed /VE=External axis speed

Choose one of the tags from the following table.

No	Tag	Explanation	Note
6	V=Tool center point speed	Specifies the tool center point speed. Specifies the unit of rate using the operation condition setting screen.	Speed: 0.1 mm to 1500.0 mm/s The units can be changed by setting the parameter S2C173. Variable B/B[]/LB/LB[]/I/I[]/LI/LI[]/D/D[]/ LD/LD[] can be used. (Units: 0.1 mm/s)
7	VR=Position angular speed	Specifies the position angular speed.	Speed: 0.1 degrees to 180.0 degrees/s Variable B/B[]/LB/LB[]/I/I[]/LI/LI[]/D/D[]/ LD/LD[] can be used. (Units: 0.1 deg/s)
8	VE=External axis speed	Specifies the external axis speed.	Speed: 0.01% to 100.00% Variable B/B[]/LB/LB[]/I/I[]/LI/LI[]/D/D[]/ LD/LD[] can be used.(Units: 0.01 %)

6. PL=Position level

The following tag can be added or omitted.

No	Tag	Explanation	Note
9	PL=Position level	Specifies the position level. The positioning level is a level of the approach when the manipulator passes the position where the teaching procedure was done.	Level: 0 to 8 Variable B/B[]/LB/LB[]/I/I[]/LI/LI[]/D/D[]/ LD/LD[] can be used.

7. NWAIT

The following tag can be added or omitted.

No	Tag	Explanation	Note
10	NWAIT	Specifies the NWAIT instruction. The NWAIT instruction carries out the instructions excluding the move instruction from that step on, at the same as time the manipulator is carrying out that step.	

DX100

2.4 Move Instruction

8. BF/RF/TF/UF# (User coordinate number)

Choose one of the tags from the following table.

No	Tag	Explanation	Note
11	BF	Specifies the increment value in the base coordinate system.	
12	RF	Specifies the increment value in the robot coordinate system.	
13	TF	Specifies the increment value in the tool coordinate system.	
14	UF#(User coordinate number)	Specifies the increment value in the user coordinate system.	No: 1 to 24 Variable B/I/D/LB/LI/LD can be used.
15	MTF	Specifies the incremental value in the master tool coordinate system. In the master tool coordinate system, position data is converted to positions relative to the master manipulator.	Available only with the optional independent/coordinated function.

9. UNTIL/SRCH/NSRCH

Choose one of the tags from the following table.

No	Tag	Explanation	Note
16	UNTIL	Specifies the UNTIL instruction. The UNTIL instruction is a tag by which the conditions of the input signal are evaluated during operation. When the condition of the input signal is full, the robot executes the next instruction.	Refer to <i>chapter 2.6 "Instruction Which Adheres to an Instruction"</i> at page 2-219.
17	SRCH	Specifies the SRCH instruction. The SRCH instruction is a tag which detects the start point.	Available only with the optional start point searching function.
18	NSRCH	Specifies the NSRCH instruction. The NSRCH instruction detects a position without stopping the motion.	Available only with the optional search-in-motion function.

10. ACC=Acceleration adjustment ratio

The following tag can be added or omitted.

No	Tag	Explanation	Note
19	ACC=Acceleration adjustment ratio	Specifies the acceleration adjustment ratio. The ACC instruction reduces the amount of acceleration in the specified ratio.	Acceleration adjustment ratio: 20% to 100% Variable B/B[]/LB/LB[]/I/I[]/LI/LI[]/D/D[]/ LD/LD[] can be used.

2.4 Move Instruction

11. DEC=Deceleration adjustment ratio

The following tag can be added or omitted.

No	Tag	Explanation	Note
20	DEC=Deceleration adjustment ratio	Specifies the deceleration adjustment ratio. The DEC instruction reduces the amount of deceleration in the specified ratio.	Deceleration adjustment ratio: 20% to 100% Variable B/B[]/LB/LB[]/I/I[]/LI/LI[]/D/D[]/ LD/LD[] can be used.

12. +IMOV

Add the following tag.

No	Tag	Explanation	Note
22	+IMOV	Specifies the move instruction for an incremental value of the master manipulator.	Available only with the optional coordinate function. Refer to the independent/coordinated function for details.

Example

(1) IMOV P000 V=138 RF

Moves from the current position at a rate of 138cm/min for the incremental value specified in P000 in the robot coordinate system.

SPEED

SUBSET	STANDARD	EXPANDED
Available	Available	Available

Function

Sets the playback speed. The manipulator operates at the speed specified in the SPEED instruction when the speed is not specified in the move instruction.

Construction

The tag which can be used is limited by the type of the job.

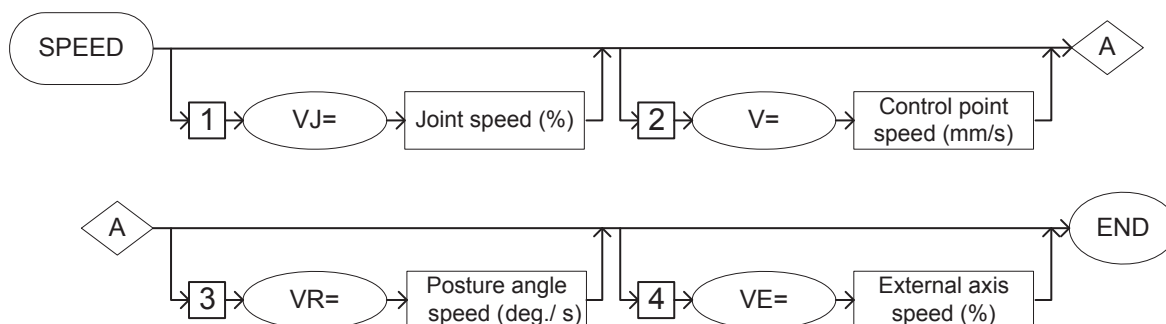

Table 2-11: Job Type and Control Group

No.	Job Type	Control group	Remarks
1	-	One manipulator (standard)	
2	-	One manipulator with station axis	
3	-	Station axis only	

Table 2-12: Availability of Each Tag

No	Tag	Control Group			Note
		1	2	3	
1	VJ=	●	●	●	
2	V=	●	●	×	
3	VR=	●	●	×	
4	VE=	×	●	×	

●: Available
×: Not available

2.4 Move Instruction

Explanation

1. VJ=Joint speed

The following tag can be added or omitted.

No	Tag	Explanation	Note
1	VJ=Joint speed	Specifies the joint speed. The joint speed is shown in the ratio to the highest speed. Operates at the speed decided beforehand when the joint speed is omitted.	Speed: 0.01% to 100.00% Variable B/B[]/LB/LB[]/I/I[]/LI/LI[]/D/D[]/ LD/LD[] can be used. (Units: 0.01 %)

2. V=Tool center point speed

The following tag can be added or omitted.

No	Tag	Explanation	Note
2	V=Tool center point speed	Specifies the tool center point speed. Specifies the unit of rate using the operation condition setting screen.	Variable B/B[]/LB/LB[]/I/I[]/LI/LI[]/D/D[]/ LD/LD[] can be used. (Units: 0.1 mm/s)

3. VR=Position angular speed

The following tag can be added or omitted.

No	Tag	Explanation	Note
3	VR=Position angular speed	Specifies the position angular speed.	Variable B/B[]/LB/LB[]/I/I[]/LI/LI[]/D/D[]/ LD/LD[] can be used. (Units: 0.1 deg/s)

4. VE=External axis speed

The following tag can be added or omitted.

No	Tag	Explanation	Note
4	VE=External axis speed	Specifies the external axis speed.	Speed: 0.01% to 100.00% Variable B/B[]/LB/LB[]/I/I[]/LI/LI[]/D/D[]/ LD/LD[] can be used.(Units: 0.01 %)

2.4 Move Instruction

Example

(1) NOP	
MOVJ VJ=100.00	Moves at the joint speed
MOVL V=138	100.00%.
	♦♦♦Moves at the control point
SPEED VJ=50.00 V=276 VR=30.0	speed 138cm/min.
MOVJ	♦♦♦Moves at the joint speed
MOVL	50.00%.
	♦♦♦Moves at the control point
MOVL VR=60.0	speed 276 cm/min.
	♦♦♦Moves at the position angular
END	speed 60.0 degree/s.

2.4 Move Instruction

REFP

SUBSET	STANDARD	EXPANDED
Available	Available	Available

Function

It is an instruction which has the position data by which a supplementary point of the wall point, etc. for weaving is set.

Construction

The tag which can be used is limited by the type of the job.

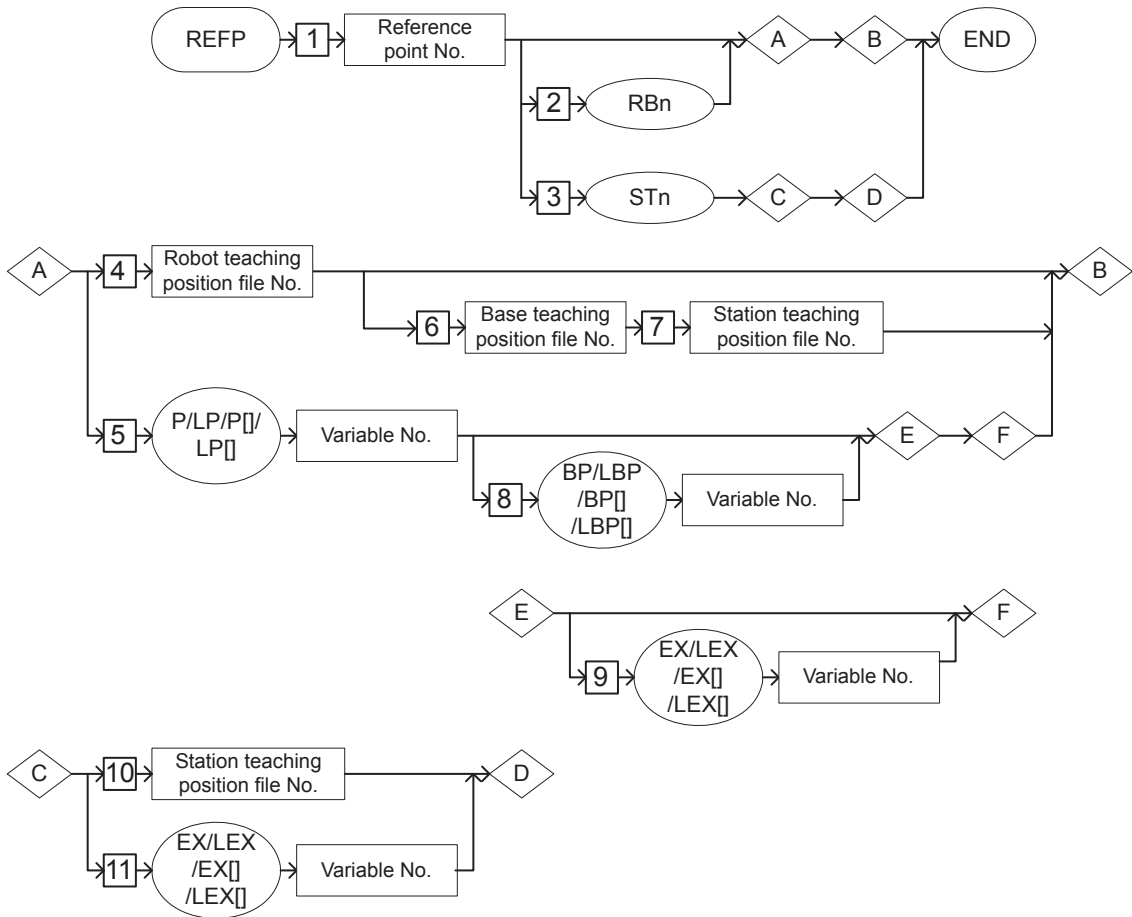

2.4 Move Instruction

Table 2-13: Job Type and Control Group

No.	Job Type	Control Group	Remarks
1	Single	One manipulator (standard)	
2	Single	One manipulator with base axis	
3	Single	One manipulator with station axis	
4	Single	One manipulator with base and station axes	
5	Single	Station axis only	
6	Coordinated	Two manipulators	Optional
7	Coordinated	Two manipulators with base axis	Optional
8	Coordinated	Coordinated job with one manipulator and the station axis (designated as master)	Optional
9	Coordinated	Coordinated job with one manipulator (with base axis) and the station axis (designated as master)	Optional

Table 2-14: Availability of Each Tag

No	Tag	Control Group									Note
		1	2	3	4	5	6	7	8	9	
1	Reference point number	●	●	●	●	●	●	●	●	●	
2	RBn	×	×	×	×	×	●	●	●	●	
3	STn	×	×	×	×	×	×	×	●	●	
4	Robot teaching position file number	●	●	●	●	×	●	●	●	●	
5	P/LP/P[]/LP[]	●	●	●	●	×	●	●	●	●	
6	Base-axis teaching position file number	×	●	×	●	×	×	●	×	●	
7	Station teaching position file number	×	×	●	●	×	×	×	×	×	
8	BP/LBP/BP[]/LBP[]	×	●	×	●	×	×	●	×	●	
9	EX/LEX/EX[]/LEX[]	×	×	●	●	×	×	×	×	×	
10	Station teaching position file number	×	×	×	×	●	×	×	●	●	
11	EX/LEX/EX[]/LEX[]	×	×	×	×	●	×	×	●	●	

●: Available

×: Not available

Explanation

1. Reference Point Number

Add the following tag.

No	Tag	Explanation	Note
1	Reference point number	Specifies the reference point (REFP) number.	Reference points: 1 to 8

2.4 Move Instruction



Reference points during weaving

Usually it is not necessary to register reference points during the weaving. However, there are cases when it must be registered according to the situation of the workpiece, etc.

In this case, the wall direction is defined as REFP1 and the horizontal wall direction is defined as REFP2.

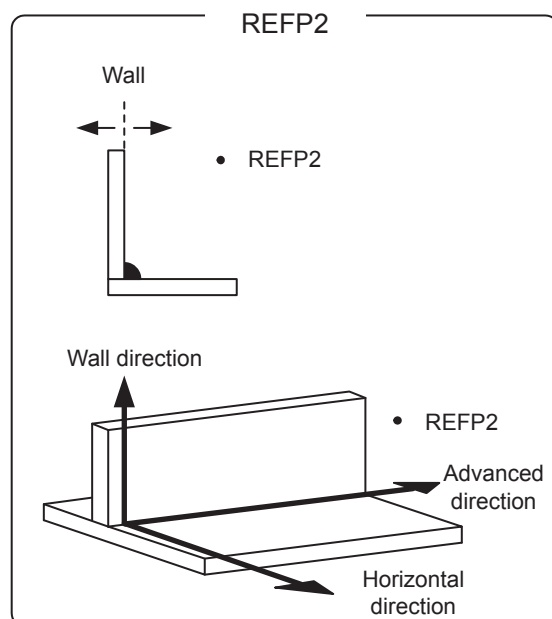
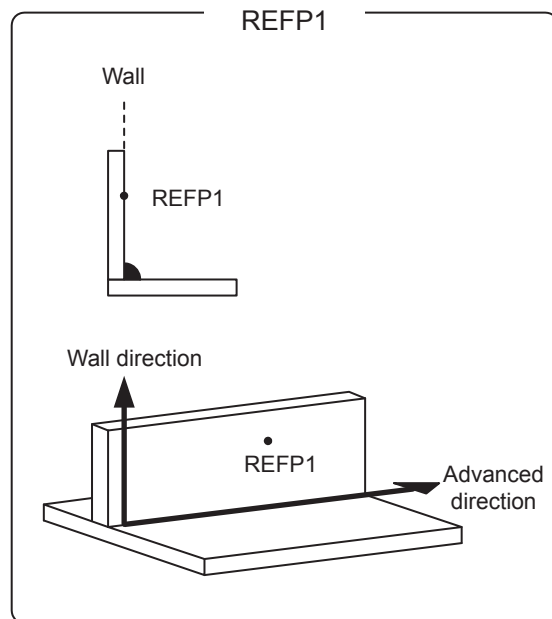

DX100

2.4 Move Instruction

2. RBn/STn

Choose one of the tags from the following table.

No	Tag	Explanation	Note
2	RBn	Specifies the robot to which the reference point is to be input.	n: 1 to 8 RB1: Robot 1
3	STn	Specifies the station to which the reference point is to be input.	n: 1 to 8 ST1: Station 1

3. Robot teaching position file number /P Variable number /LP Variable number /P [Array number] /LP [Array number]

Choose one of the tags from the following table.

No	Tag	Explanation	Note
4	Robot teaching position file number	The position in the reference point where the robot axis is taught is unconditionally written in this file. This teaching position cannot be edited.	On the job display, this tag is not displayed.
5	P Variable number/ LP Variable number/ P [Array number]/ LP [Array number]	Specifies the position variable number of the robot axis. The position data set in the variable of the specified number becomes a reference point.	Variable number: 000 to 127

4. Base Teaching Position File Number

When the robot teaching position file number is selected from the table in part 3 of this Explanation, add the following tag.

No	Tag	Explanation	Note
6	Base teaching position file number	The position in the reference point where the base axis is taught is unconditionally written in this file. This teaching position cannot be edited.	On the job display, this tag is not displayed.

5. Station Teaching Position File Number

When the robot teaching position file number is selected from the table in part 3 of this Explanation, add the following tag.

No	Tag	Explanation	Note
7	Station teaching position file number	The position in the reference point where the station axis is taught is unconditionally written in this file. This teaching position cannot be edited.	On the job display, this tag is not displayed.

2.4 Move Instruction

6. BP Variable number /LBP Variable number /BP
[Array number] /LBP [Array number]

When a P Variable number, LP Variable number, P [Array number], or LP [Array number] is selected from the table in part 3 of this Explanation, the following tag can be added.

No	Tag	Explanation	Note
8	BP Variable number/ LBP Variable number/ BP [Array number]/ LBP [Array number]	Specifies the position variable number of the base axis. The position data set in the variable of the specified number becomes a reference point.	Variable number: 000 to 127

7. EX Variable number /LEX Variable number /EX
[Array number] /LEX [Array number]

When a P Variable number, LP Variable number, P [Array number], or LP [Array number] is selected from the table in part 3 of this Explanation, the following tag can be added.

No	Tag	Explanation	Note
9	EX Variable number/ LEX Variable number/ EX [Array number]/ LEX [Array number]	Specifies the position variable number of the station axis. The position data set in the variable of the specified number becomes a reference point.	Variable number: 000 to 127

8. Station teaching position file number/EX Variable
number /LEX Variable number /EX [Array number] /
LEX [Array number]

Choose one of the tags from the following table.

No	Tag	Explanation	Note
10	Station teaching position file number	The station axis teaching position in each step is written in this file unconditionally when the step is taught. This teaching position cannot be edited.	On the job display, this tag is not displayed.
11	EX Variable number/ LEX Variable number/ EX [Array number]/ LEX [Array number]	Specifies the position variable number of the station axis. The position data set in the variable of a specified number becomes a reference point.	Variable number: 000 to 127

2.4 Move Instruction

Example

Register REFP1 when the wall direction and the Z direction of the robot axis are different.

```

:
:
MOV L V=138
ARCON ASF#(1)
REFP 1
MOV L V=138
:
:

```

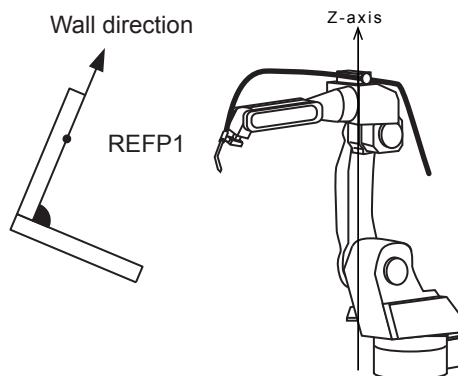

- (2) Register REFP2 when the approach point is on the other side of the wall.

```

:
:
MOV J VJ=25.00◆◆◆Approach point
MOV L V=138
ARCON ASF#(1)
REFP 2
MOV L V=138
:
:

```

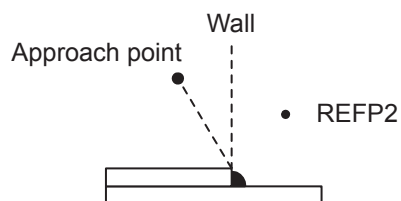

2.5 Shift Instruction

SFTON

SUBSET	STANDARD	EXPANDED
Available	Available	Available

Function

Begins the parallel shift operation. The amount of the parallel shift is set in a positional variable by the increment value of X, Y, and Z in each coordinate system.

Construction

The tag which can be used is limited by the type of the job.

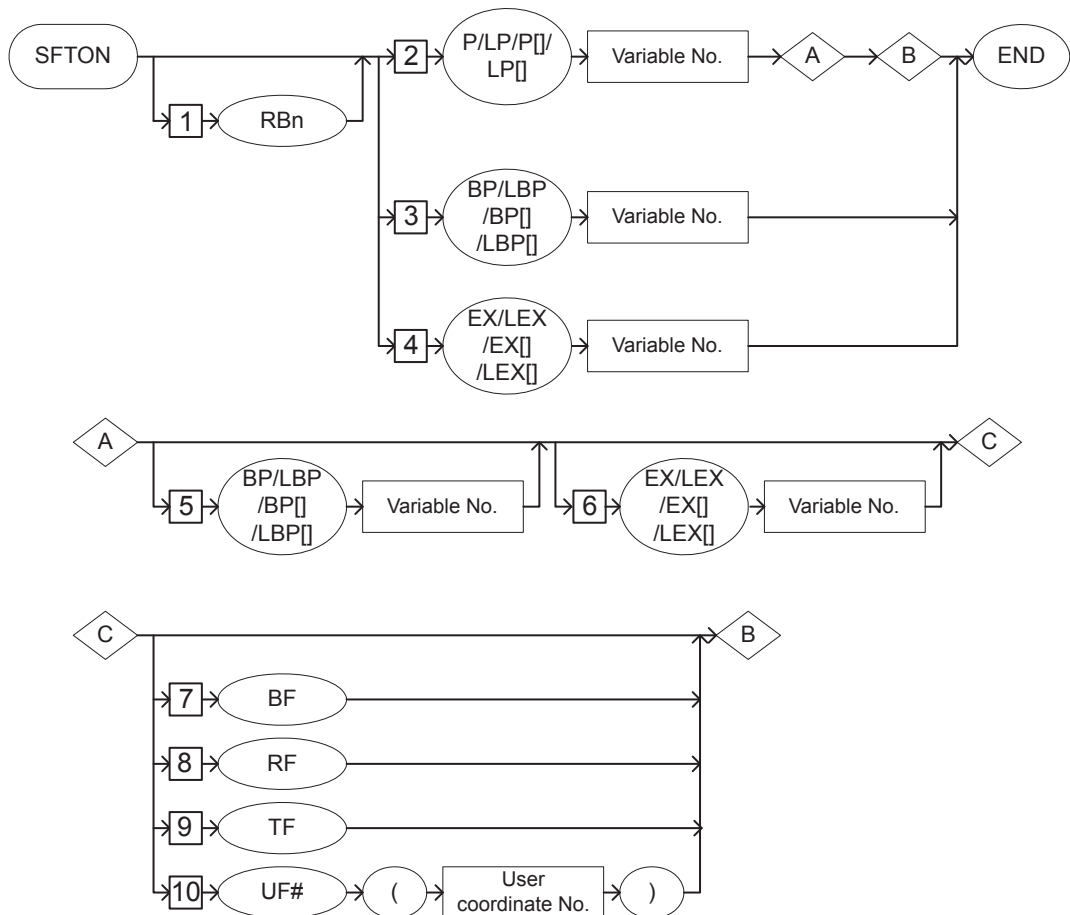

2.5 Shift Instruction

Table 2-15: Job Type and Control Group

No.	Job Type	Control Group	Remarks
1	Single	One manipulator (standard)	
2	Single	One manipulator with base axis	
3	Single	One manipulator with station axis	
4	Single	One manipulator with base and station axes	
5	Single	Station axis only	
6	Coordinated	Two manipulators	Optional
7	Coordinated	Two manipulators with base axis	Optional
8	Coordinated	Coordinated job with one manipulator and the station axis (designated as master)	Optional
9	Coordinated	Coordinated job with one manipulator (with base axis) and the station axis (designated as master)	Optional

Table 2-16: Availability of Each Tag

No	Tag	Control Group									Note
		1	2	3	4	5	6	7	8	9	
1	RBn	x	x	x	x	x	●	●	●	●	
2	P/LP/P[]/LP[]	●	●	●	●	x	●	●	●	●	
3	BP/LBP/BP[]/LBP[]	x	●	x	●	x	x	●	x	●	
4	EX/LEX/EX[]/LEX[]	x	x	●	●	●	x	x	●	●	
5	BP/LBP/BP[]/LBP[]	x	●	x	●	x	x	●	x	●	
6	EX/LEX/EX[]/LEX[]	x	x	●	●	x	x	x	●	●	
7	BF	●	●	●	●	x	●	●	●	●	
8	RF	●	●	●	●	x	●	●	●	●	
9	TF	●	●	●	●	x	●	●	●	●	
10	UF#()	●	●	●	●	x	●	●	●	●	

●: Available

x: Not available

Explanation

1. RBn

Choose one of the tags from the following table.

No	Tag	Explanation	Note
1	RBn	Specifies the robot that is to execute a shift operation.	n: 1 to 8 RB1: Robot 1

2.5 Shift Instruction

2. P Variable number /LP Variable number /P [Array number] /LP [Array number] /BP Variable number /LBP Variable number /BP [Array number] /LBP [Array number] /EX Variable number /LEX Variable number /EX [Array number] /LEX [Array number]

Choose one of the tags from the following table.

No	Tag	Explanation	Note
2	P Variable number/ LP Variable number/ P [Array number]/ LP [Array number]	Specifies the position variable number of the robot axis by which the shift value is set. Only the increment value set in the variable of the specified number shifts.	Variable number: 000 to 127
3	BP Variable number/ LBP Variable number/ BP [Array number]/ LBP [Array number]	Specifies the position variable number of the base axis by which the shift value is set. Only the increment value set in the variable of the specified number shifts.	Variable number: 000 to 127
4	EX Variable number/ LEX Variable number/ EX [Array number]/ LEX [Array number]	Specifies the position variable number of the station axis by which the shift value is set. Only the increment value set in the variable of the specified number shifts.	Variable number: 000 to 127

3. BP Variable number /LBP Variable number /BP [Array number] /LBP [Array number]

When a P Variable number, LP Variable number, P [Array number], or LP [Array number] is selected from the table in part 2 of this Explanation, the following tag can be added.

No	Tag	Explanation	Note
5	BP Variable number/ LBP Variable number/ BP [Array number]/ LBP [Array number]	Specifies the position variable number of the base axis by which the shift value is set. Only the increment value set in the variable of the specified number shifts.	Variable number: 000 to 127

4. EX Variable number /LEX Variable number /EX [Array number] /LEX [Array number]

When a P Variable number, LP Variable number, P [Array number], or LP [Array number] is selected from the table in part 2 of this Explanation, the following tag can be added.

No	Tag	Explanation	Note
6	EX Variable number/ LEX Variable number/ EX [Array number]/ LEX [Array number]	Specifies the position variable number of the station axis by which the shift value is set. Only the increment value set in the variable of the specified number shifts.	Variable number: 000 to 127

2.5 Shift Instruction

5. BF/RF/TF/UF# (User coordinate number)

When a P Variable number, LP Variable number, P [Array number], or LP [Array number] is selected from the table in part 2 of this Explanation, choose one of the tags from the following table.

No	Tag	Explanation	Note
7	BF	Specifies the increment value in the base coordinate system.	
8	RF	Specifies the increment value in the robot coordinate system.	
9	TF	Specifies the increment value in the tool coordinate system.	
10	UF#(User coordinate number)	Specifies the increment value in the user coordinate system.	No.1 to 63 Variable B//D/LB/LI/LD can be used.

Example

```
(1) NOP
    MOVJ VJ=50.0
    MOVL V=138
    SFTON P000 UF#(1)
    MOVL V=138
    MOVL V=138
    MOVL V=138
    SFTOF
    MOVL V=138
    ⋮
```

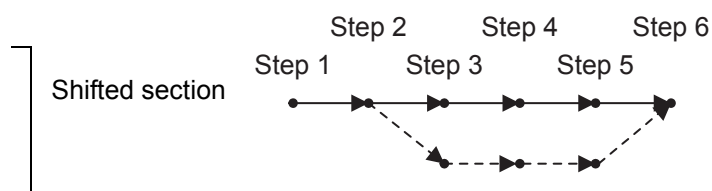

Shift between Step 3 and Step 5 in the user coordinate system.

2.5 Shift Instruction

SFTOF

SUBSET	STANDARD	EXPANDED
Available	Available	Available

Function

Ends the parallel shift operation.

Construction

The tags to be added are decided according to the type of the job.

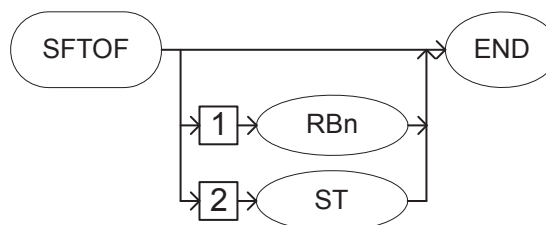

Table 2-17: Job Type and Control Group

No.	Job Type	Control group	Remarks
1	Single	One manipulator (standard)	
2	Coordinated	Two manipulators (without station axis)	Optional
3	Coordinated	Two manipulators (with station axis)	Optional

Table 2-18: Availability of Each Tag

No	Tag	Control group			Note
		1	2	3	
1	RBn	x	•	•	
2	ST	x	x	•	

•: Available
x: Not available

Explanation

1. RBn/ST

Choose one of the tags from the following table.

No.	Tag	Explanation	Note
1	RBn	Specifies the robot that is to end the shift operation.	n: 1 to 8 RB1: Robot 1
2	ST	Ends the station axis shift operation.	

2.5 Shift Instruction

Example

```

(1) NOP
    MOVJ VJ=50.0
    MOVL V=138
    SFTON P000 UF#(1)
    MOVL V=138
    MOVL V=138
    MOVL V=138
    SFTOF
    MOVL V=138
    ⋮
  
```

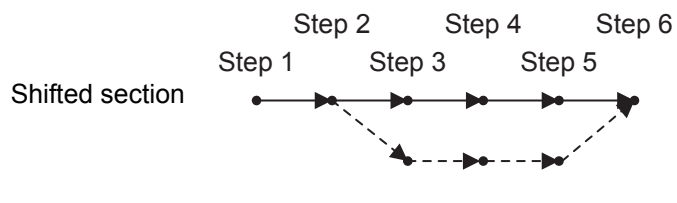

Shift between Step 3 and Step 5 in the user coordinate system.

MSHIFT

SUBSET	STANDARD	EXPANDED
Not available	Available	Available

Function

Calculates the amount of the shift in the specified coordinate system according to Data 2 and Data 3 and stores the result in Data 1.

Data 2 indicates the reference position to carry out the parallel shift, and Data 3 is the target position (shifted position).

Construction

MSHIFT <Data 1> Coordinate system designation <Data 2> <Data 3>

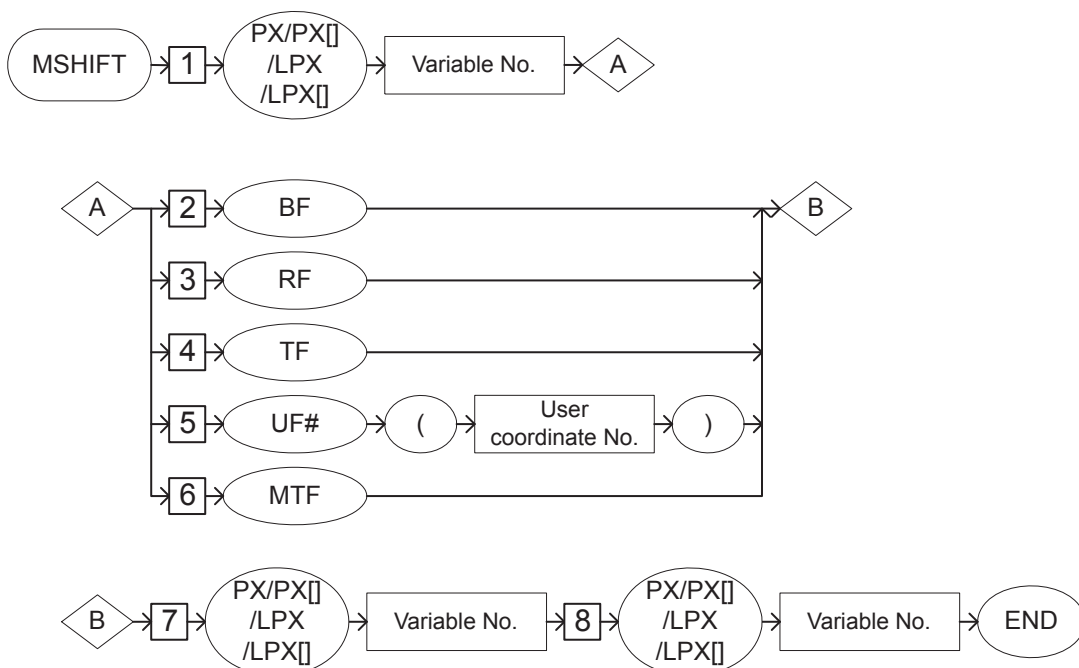

Explanation

1. PX Variable number/LPX Variable number/PX [Array number]/LPX [Array number]

Add the following tag.

No.	Tag	Explanation	Note
1	PX Variable number/ LPX Variable number/ PX [Array number]/ LPX [Array number]	Specifies the number of the expanded position variable to store the calculated shift.	<Data 1>

DX100

2.5 Shift Instruction

2. BF/RF/TF/UF# (User coordinate number)/MTF

Choose one of the tags from the following table.

No.	Tag	Explanation	Note
2	BF	Specifies the calculation of the shift amount in the base coordinate system.	
3	RF	Specifies the calculation of the shift amount in the robot coordinate system.	
4	TF	Specifies the calculation of the shift amount in the tool coordinate system.	
5	UF# (User coordinate number)	Specifies the calculation of the shift amount in the user coordinate system.	No.: 1 to 63 Variable B/I/D/LB/LI/LD can be used.
6	MTF	Specifies the calculation of the shift amount in the master tool coordinate system.	Available only with the optional independent/coordinated function.

3. PX Variable number/LPX Variable number/PX [Array number]/LPX [Array number]

Add the following tag.

No.	Tag	Explanation	Note
7	PX Variable number/ LPX Variable number/ PX [Array number]/ LPX [Array number]	Specifies the expanded position type variable number of the reference position to calculate the amount of the shift.	<Data 2>

4. PX Variable number/LPX Variable number/PX [Array number]/LPX [Array number]

Add the following tag.

No.	Tag	Explanation	Note
8	PX Variable number/ LPX Variable number/ PX [Array number]/ LPX [Array number]	Specifies the expanded position type variable number of the target position to calculate the amount of the shift.	<Data 3>

Example

(1) NOP	: Moves to the reference position.
MOVJ VJ=20.00	: Sets the current position (the reference position) in the position variable P000.
GETS PX000 \$PX000	
MOVJ VJ=20.00	: Moves to the target position.
GETS PX001 \$PX000	: Sets the current position (the target position) in the position variable P001.
MSHIFT PX010 BF PX000 PX001	: Calculates the shift amount and stores it in the position variable P010.
END	

2.6 Instruction Which Adheres to an Instruction

IF

SUBSET	STANDARD	EXPANDED
Available	Available	Available

Function

Evaluates the various conditions during operation. This instruction is added after other instructions for processing.

Construction

IF <Comparison element 1> =, <>, <=, >=, <, > <Comparison element 2>

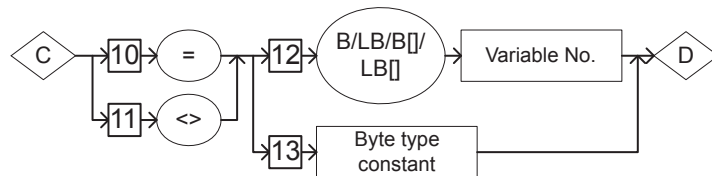
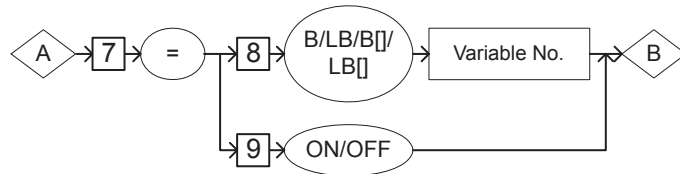
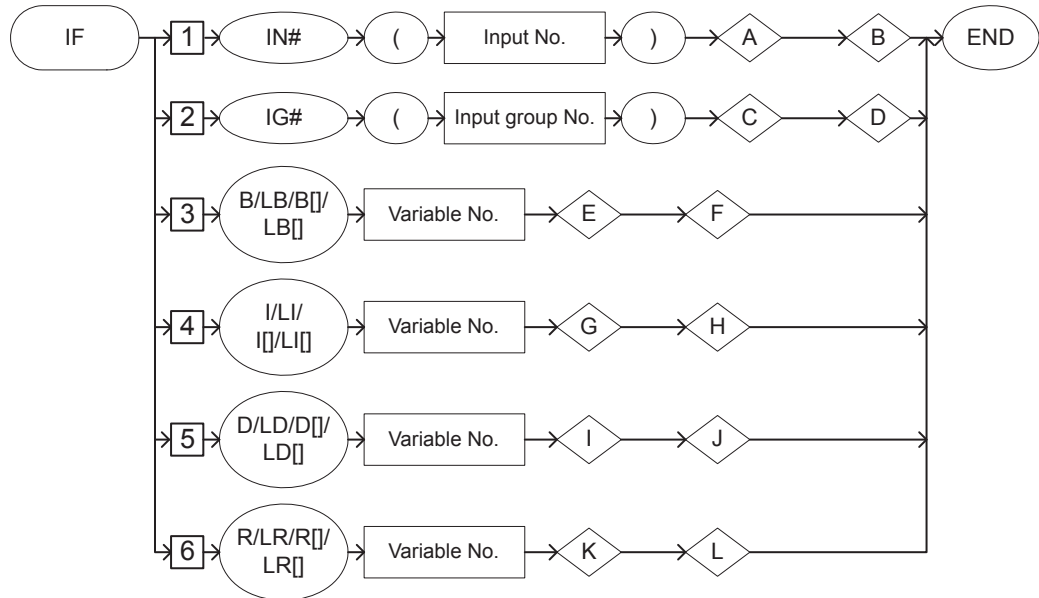

2.6 Instruction Which Adheres to an Instruction

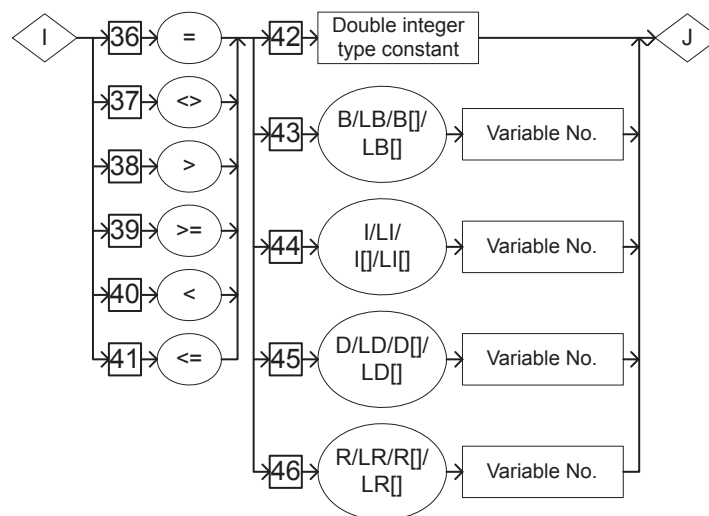
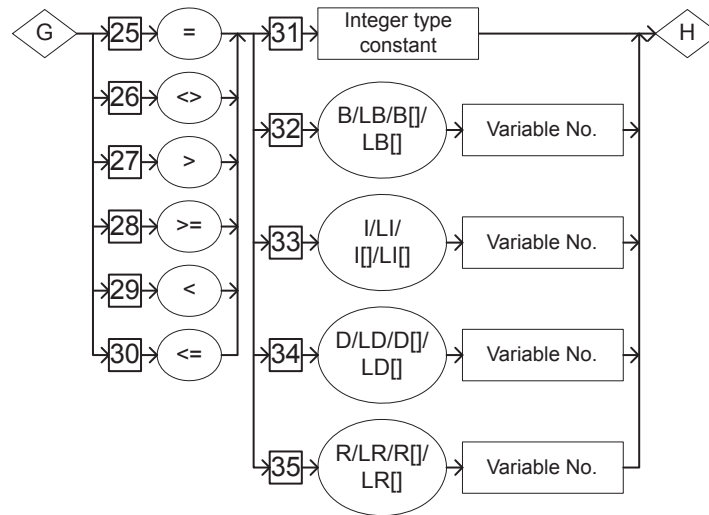
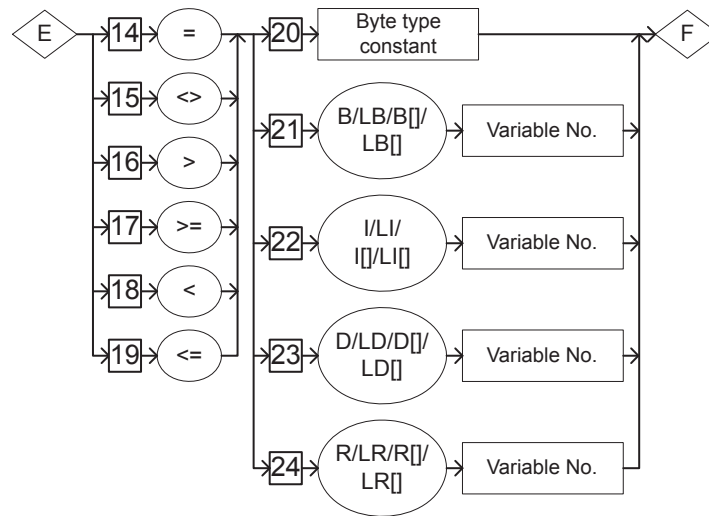

2.6 Instruction Which Adheres to an Instruction

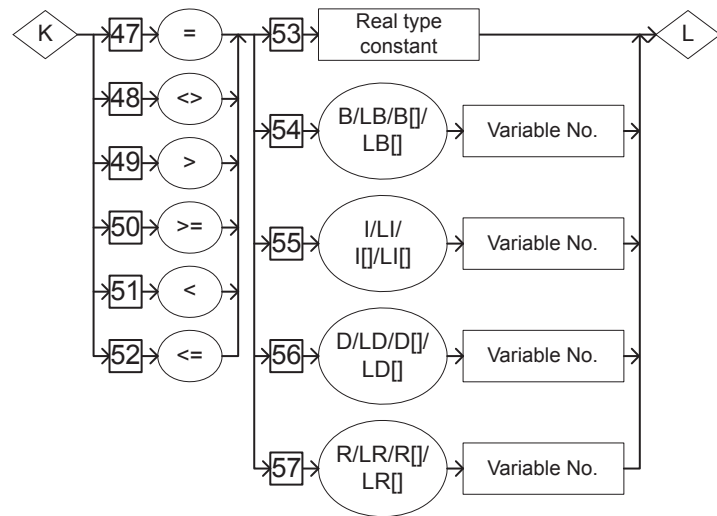
**Explanation**

- IN# (Input number) /IG# (Input group number) /B Variable number /LB Variable number /B [Array number] /LB [Array number] /I Variable number /LI Variable number /I [Array number] /LI [Array number] /D Variable number /LD Variable number /D [Array number] /LD [Array number] /R Variable number /LR Variable number /R [Array number] /LR [Array number]

Choose one of the tags from the following table.

No	Tag	Explanation	Note
1	IN# (Input number)	Specifies the number of the general input signal to be compared.	<Comparison element 1> No.: 1 to 2048 Variable B/I/D/LB/LI/LD can be used.
2	IG# (Input group number)	Specifies the number of the general input group signal to be compared.	<Comparison element 1> No.: 1 to 256 Variable B/I/D/LB/LI/LD can be used.
3	B Variable number/ LB Variable number/ B [Array number]/ LB [Array number]	Specifies the number of the byte type variable to be compared.	<Comparison element 1>

DX100

2.6 Instruction Which Adheres to an Instruction

No	Tag	Explanation	Note
4	I Variable number/ LI Variable number/ I [Array number]/ LI [Array number]	Specifies the number of the integer type variable to be compared.	<Comparison element 1>
5	D Variable number/ LD Variable number/ D [Array number]/ LD [Array number]	Specifies the number of the double precision type variable to be compared.	<Comparison element 1>
6	R Variable number/ LR Variable number/ R [Array number]/ LR [Array number]	Specifies the number of the real type variable to be compared.	<Comparison element 1>

2. =

When an IN#(Input number) is selected from the table in part 1 of this Explanation, add the following tag.

No	Tag	Explanation	Note
7	=	It is equal.	

3. B Variable number /LB Variable number /B [Array number] /LB [Array number] /ON /OFF

When an IN#(Input number) is selected from the table in part 1 of this Explanation, choose one of the tags from the following table after the equal sign (=) is added from the table in part 2 of this Explanation.

No	Tag	Explanation	Note
8	B Variable number/ LB Variable number/ B [Array number]/ LB [Array number]	Specifies the byte type variable which becomes a comparison condition.	<Comparison element 2> Least significant bit: 0: OFF 1: ON
9	ON/OFF	The comparison condition is specified as ON or OFF.	<Comparison element 2>

4. =/<>

When an IG#(Input group number) is selected from the table in part 1 of this Explanation, choose one of the tags from the following table.

No	Tag	Explanation	Note
10	=	It is equal.	
11	<>	It is not equal.	

2.6 Instruction Which Adheres to an Instruction

5. B Variable number /LB Variable number /B [Array number] /LB [Array number] /ON /OFF

When an IG#(Input group number) is selected from the table in part 1 of this Explanation, choose one of the tags from the following table after “=” or “<>” are added from the table in part 4 of this Explanation.

No	Tag	Explanation	Note
12	B Variable number/ LB Variable number/ B [Array number]/ LB [Array number]	Specifies the byte type variable which becomes a comparison condition.	<Comparison element 2>
13	Byte type constant	The comparison condition is specified by byte type constant.	<Comparison element 2>

6. =/<>/>/>= /</<=

When a B Variable number, LB Variable number, B [Array number], or LB [Array number] is selected from the table in part 1 of this Explanation, choose one of the tags from the following table.

No	Tag	Explanation	Note
14	=	It is equal.	
15	<>	It is not equal.	
16	>	It is greater than.	
17	>=	It is greater than or equal.	
18	<	It is less than.	
19	<=	It is less than or equal.	

7. Byte type constant /B Variable number /LB Variable number /B [Array number] /LB [Array number] /I Variable number /LI Variable number /I [Array number] /LI [Array number] /D Variable number /LD Variable number /D [Array number] /LD [Array number] /R Variable number /LR Variable number /R [Array number] /LR [Array number]

When a B Variable number, LB Variable number, B [Array number], or LB [Array number] is selected from the table in part 1 of this Explanation, choose one of the tags in the following table after “=”, “<>”, “>”, “>=”, “<” or “<=” is selected from the table in part 6 of this Explanation.

No	Tag	Explanation	Note
20	Byte type constant	The comparison condition is specified by the byte type constant.	<Comparison element 2>
21	B Variable number/ LB Variable number/ B [Array number]/ LB [Array number]	Specifies the byte type variable number which becomes a comparison condition.	<Comparison element 2>

2.6 Instruction Which Adheres to an Instruction

No	Tag	Explanation	Note
22	I Variable number/ LI Variable number/ I [Array number]/ LI [Array number]	Specifies the integer type variable number which becomes a comparison condition.	<Comparison element 2>
23	D Variable number/ LD Variable number/ D [Array number]/ LD [Array number]	Specifies the double precision type variable number which becomes a comparison condition.	<Comparison element 2>
24	R Variable number/ LR Variable number/ R [Array number]/ LR [Array number]	Specifies the real type variable number which becomes a comparison condition.	<Comparison element 2>

8. =/<>/>/>=</<=

When an I Variable number, LI Variable number, I [Array number] or LI [Array number] is selected the table in part 1 of this Explanation, choose one of the tags from the following table.

No	Tag	Explanation	Note
25	=	It is equal.	
26	<>	It is not equal.	
27	>	It is greater than.	
28	>=	It is greater than or equal.	
29	<	It is less than.	
30	<=	It is less than or equal.	

9. Integer type constant /B Variable number /LB Variable number /B [Array number] /LB [Array number] /I Variable number /LI Variable number /I [Array number] /LI [Array number] /D Variable number /LD Variable number /D [Array number] /LD [Array number] /R Variable number /LR Variable number /R [Array number] /LR [Array number]

When an I Variable number, LI Variable number, I [Array number], or LI [Array number] is selected from the table in part 1 of this Explanation, choose one of the tags from the following table after selecting "=", "<>", ">", ">=", "<" or "<=" from the table in part 8 of this Explanation.

No	Tag	Explanation	Note
31	Integer type constant	The comparison condition is specified by the integer type constant.	<Comparison element 2>
32	B Variable number/ LB Variable number/ B [Array number]/ LB [Array number]	Specifies the byte type variable number which becomes a comparison condition.	<Comparison element 2>

2.6 Instruction Which Adheres to an Instruction

No	Tag	Explanation	Note
33	I Variable number/ LI Variable number/ I [Array number]/ LI [Array number]	Specifies the integer type variable number which becomes a comparison condition.	<Comparison element 2>
34	D Variable number/ LD Variable number/ D [Array number]/ LD [Array number]	Specifies the double precision type variable number which becomes a comparison condition.	<Comparison element 2>
35	R Variable number/ LR Variable number/ R [Array number]/ LR [Array number]	Specifies the real type variable number which becomes a comparison condition.	<Comparison element 2>

10. =/<>/>/>=/</<=

When a D Variable number, LD Variable number, D [Array number] or LD [Array number] is selected from the table in part 1 of this Explanation, choose one of the tags from the following table.

No	Tag	Explanation	Note
36	=	It is equal.	
37	<>	It is not equal.	
38	>	It is greater than.	
39	>=	It is greater than or equal.	
40	<	It is less than.	
41	<=	It is less than or equal.	

11. Double precision type constant/ B Variable number /LB Variable number /B [Array number] /LB [Array number] /I Variable number /LI Variable number /I [Array number] /LI [Array number] /D Variable number /LD Variable number /D [Array number] /LD [Array number] /R Variable number /LR Variable number /R [Array number] /LR [Array number]

When a D Variable number, LD Variable number, D [Array number], or LD [Array number] is selected from the table in part 1 of this Explanation, choose one of the tags from the following table after "=", "<>", ">", ">=", "<" or "<=" is selected from the table in part 10 of this Explanation.

No	Tag	Explanation	Note
42	Double precision type constant	The comparison condition is specified by the double precision type constant.	<Comparison element 2>
43	B Variable number/ LB Variable number/ B [Array number]/ LB [Array number]	Specifies the byte type variable number which becomes a comparison condition.	<Comparison element 2>

2.6 Instruction Which Adheres to an Instruction

No	Tag	Explanation	Note
44	I Variable number/ LI Variable number/ I [Array number]/ LI [Array number]	Specifies the integer type variable number which becomes a comparison condition.	<Comparison element 2>
45	D Variable number/ LD Variable number/ D [Array number]/ LD [Array number]	Specifies the double precision type variable number which becomes a comparison condition.	<Comparison element 2>
46	R Variable number/ LR Variable number/ R [Array number]/ LR [Array number]	Specifies the real type variable number which becomes a comparison condition.	<Comparison element 2>

12. =/<>/>/>=/</<=

When an R Variable number, LR Variable number, R [Array number] or LR [Array number] is selected from the table in part 1 of this Explanation, choose one of the tags from the following table.

No	Tag	Explanation	Note
47	=	It is equal.	
48	<>	It is not equal.	
49	>	It is greater than.	
50	>=	It is greater than or equal.	
51	<	It is less than.	
52	<=	It is less than or equal.	

13. Real type constant /B Variable number /LB Variable number /B [Array number] /LB [Array number] /I Variable number /LI Variable number /I [Array number] /LI [Array number] /D Variable number /LD Variable number /D [Array number] /LD [Array number] /R Variable number /LR Variable number /R [Array number] /LR [Array number]

When an R Variable number, LR Variable number, R [Array number], or LR [Array number] is selected from the table in part 1 of this Explanation, choose one of the tags from the following table after "=", "<>", ">", ">=", "<" or "<=" is selected from the table in part 12 of this Explanation.

No	Tag	Explanation	Note
53	Real type constant	The comparison condition is specified by the real type constant.	<Comparison element 2>
54	B Variable number/ LB Variable number/ B [Array number]/ LB [Array number]	Specifies the byte type variable number which becomes a comparison condition.	<Comparison element 2>

2.6 Instruction Which Adheres to an Instruction

No	Tag	Explanation	Note
55	I Variable number/ LI Variable number/ I [Array number]/ LI [Array number]	Specifies the integer type variable number which becomes a comparison condition.	<Comparison element 2>
56	D Variable number/ LD Variable number/ D [Array number]/ LD [Array number]	Specifies the double precision type variable number which becomes a comparison condition.	<Comparison element 2>
57	R Variable number/ LR Variable number/ R [Array number]/ LR [Array number]	Specifies the real type variable number which becomes a comparison condition.	<Comparison element 2>

Example

- (1) SET B000 1
JUMP B000 IF IN#(14)=ON
It jumps to Job 1 if input signal No.14 is turned ON.
- (2) JUMP *2 IF D005<=D006
Jumps to *2 if D005 is below D006.

UNTIL

SUBSET	STANDARD	EXPANDED
Not available	Available	Available

Function

Evaluates the input conditions during operation. This instruction is added after other instructions for processing.

Construction

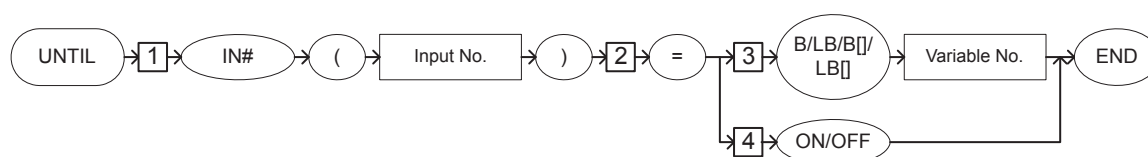

Explanation

1. IN# (Input number)

Add the following tag.

No.	Tag	Explanation	Note
1	IN# (Input number)	Specifies the number of the general-purpose input signal which becomes a input condition.	No.: 1 to 2048 Variable B/I/D/LB/LI/LD can be used.

2. =

Add the following tag.

No.	Tag	Explanation	Note
2	=	It is equal.	

3. B Variable number/LB Variable number/B [Array number]/LB [Array number]/ON/OFF.

Choose one of the tags from the following table after “=” is selected from the table in part 2 of this Explanation.

No.	Tag	Explanation	Note
3	B Variable number/ LB Variable number/ B [Array number]/ LB [Array number]	Specifies the byte type variable to be the condition of execution.	Least significant bit: 0: OFF 1: ON
4	ON/OFF	Specifies the condition as ON or OFF.	

2.6 Instruction Which Adheres to an Instruction

Example

- (1) Step 1 MOVJ VJ=100.00
- Step 2 MOVJ VJ=50.00 UNTIL IN#(14)=ON
- Step 3 MOVJ VJ=25.00

The axis moves toward Step 2 until input signal No. 14 is turned ON. When input signal No. 14 is turned ON, the axis moves toward Step 3.

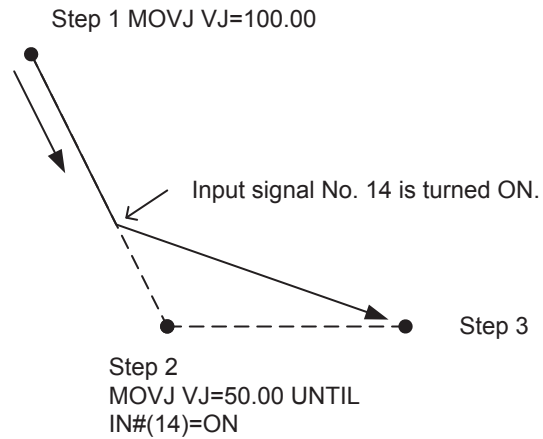

ENWAIT

SUBSET	STANDARD	EXPANDED	Parameter
Available	Available	Available	S2C714

Function

Carries out, in advance for the specified time, an instruction other than a move instruction on the instruction line next to the move instruction that was added with ENWAIT.

Construction

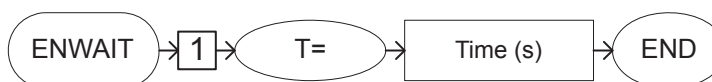

Explanation

1. T=Time

Add the following tag.

No.	Tag	Explanation	Note
1	T=Time	Specifies the time in which the next instruction excluding a move instruction is carried out.	Time: 0 to 655.36 seconds Variable I/L/I []/LI [] can be used. (Units: 0.01 seconds)

Example

- (1) Step 1 MOVL V=136
 Step 2 MOVL V=136 ENWAIT T=3.00
 DOUT OT#(1) ON

DOUT on the next instruction line is carried out 3 seconds before reaching Step 2.

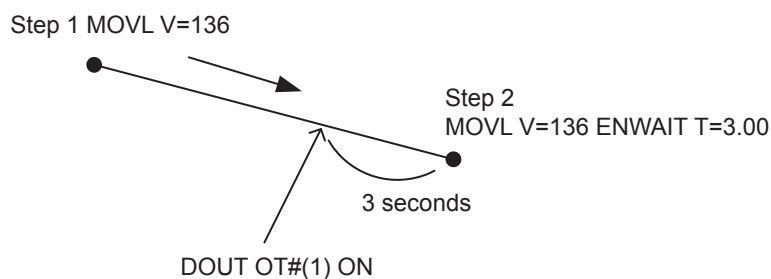

2.7 Arc Welding Instruction

ARCON

SUBSET	STANDARD	EXPANDED	APPLICATIONS
Available	Available	Available	Arc

Function

Outputs the welding start command.

Construction

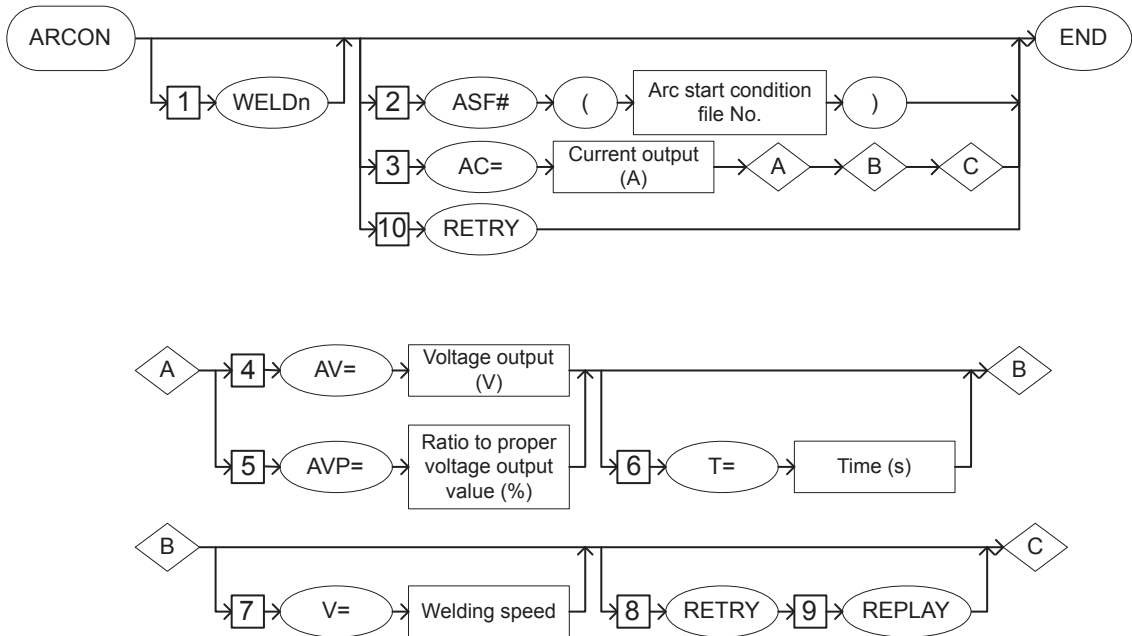

DX100

2.7 Arc Welding Instruction

Explanation

1. WELDn

Choose one of the tags from the welder. These tags are valid for a system with multiple applications in which two or more arc welding applications are included. These tags are not displayed when there is only one application.

No	Tag	Explanation	Note
1	WELDn	Specifies the welder.	n: 1 to 8 WELD1: Welder 1

2. ASF# (Arc start condition file number) /AC=Current output value

Choose one of the tags from the following table.

No	Tag	Explanation	Note
2	ASF#(Arc start condition file number)	Specifies the arc start condition file number. The condition when the welding begins is registered in the arc start condition file.	No: 1 to 396 Variable B/I/D/LB/LI/LD can be used.
3	AC=Current output value	Specifies the output value of the welding current.	Current value: 1 to 999A Variable B/I/D/B[]/I[]/D[]/LB/LI/LD/LB[]/LI[]/LD[] can be used.

3. AV=Voltage output value /AVP=Ratio to proper voltage output value

When AC=Current output value is selected from the table in part 2 of this Explanation, choose one of the tags from the following table.

No	Tag	Explanation	Note
4	AV=Voltage output value	Specifies the output value of the arc voltage. When the welder power supply is 'Individual', the output value of the arc voltage is specified.	Voltage value: 0.1V to 50.0 V Variable B/I/D/B[]/I[]/D[]/LB/LI/LD/LB[]/LI[]/LD[] can be used. (Units: 0.1V)
5	AVP=Ratio to proper voltage output value	Specifies the ratio to the aptitude output value of the arc voltage. When the welder power supply is 'Same', the ratio to the aptitude output value of the arc voltage is specified.	Ratio: 50% to 150% Variable B/I/D/B[]/I[]/D[]/LB/LI/LD/LB[]/LI[]/LD[] can be used.

2.7 Arc Welding Instruction

4. T=Time

When AC=Current output value is selected from the table in part 2 of this Explanation, the following tag can be added or omitted.

No	Tag	Explanation	Note
6	T=Time	Specifies the timer value at the welding start.	Unit: Seconds Variable I/LI/I[]/LI[] can be used. (Units: 0.01 seconds)

5. V=Welding speed

When AC=Current output value is selected from the table in part 2 of this Explanation, the following tag can be added or omitted.

No	Tag	Explanation	Note
7	V=Welding speed	Specifies the speed while welding. Specifies the unit of rate using the operation condition setting screen.	Speed: 0.1 mm to 1500.0 mm/s Setting the parameter S2C101 can change the units. Variable B/B[]/LB/LB[]/I/I[]/LI/LI[]/D/D[]/LD/LD[] can be used. (Units: 0.1 mm/s)

6. RETRY

When AC=Current output value is selected from the table in part 2 of this Explanation, the following tag can be added or omitted.

No	Tag	Explanation	Note
8	RETRY	Specifies the RETRY function. The RETRY function makes it so that the manipulator does not stop and work is not interrupted when an arc generation error occurs.	Refer to the supplement "RETRY function".

7. REPLAY

When RETRY is selected from the table in part 6 of this Explanation, add the following tag.

No	Tag	Explanation	Note
9	REPLAY	Specifies the REPLAY mode. REPLAY mode is one of the operation modes. When the RETRY function is available, the ARCON processing can be done again.	Refer to the supplement "RETRY function".

2.7 Arc Welding Instruction



RETRY function

The RETRY function performs the arc retry automatically with a condition set in the auxiliary condition file, when an arc generation error occurs.

When ARCON is processed again, the arc is generated and the manipulator continues working.

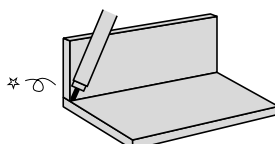

1. Arc generation mistake.

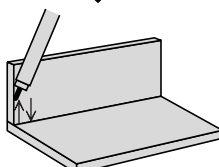

2. ARCON is processed again.

- **REPLAY mode**
Returns to the former step, performs retract inching, returns to the start point and tries the arc again.

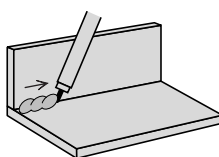

3. Keeps working when the arc is generated.



For details of the RETRY function, refer to the “Operator’s Manual for Arc Welding”.

2.7 Arc Welding Instruction

Example

(1) Starts welding with the condition set to No.1 in the arc start condition file.

(2) NOP	
MOVJ VJ=50.00	◆◆◆ Step 1
MOVL V=200	◆◆◆ Step 2
MOVL V=220	◆◆◆ Step 3
WVON WEV#(2)	◆◆◆ Weaving starts
ARCON AC=220 AVP=100 T=0.50	◆◆◆ Welding starts
MOVL V=138	◆◆◆ Step 4
ARCOF	◆◆◆ Welding ends
WVOF	◆◆◆ Weaving ends
MOVL V=200	◆◆◆ Step 5
MOVJ VJ=50.00	◆◆◆ Step 6
END	

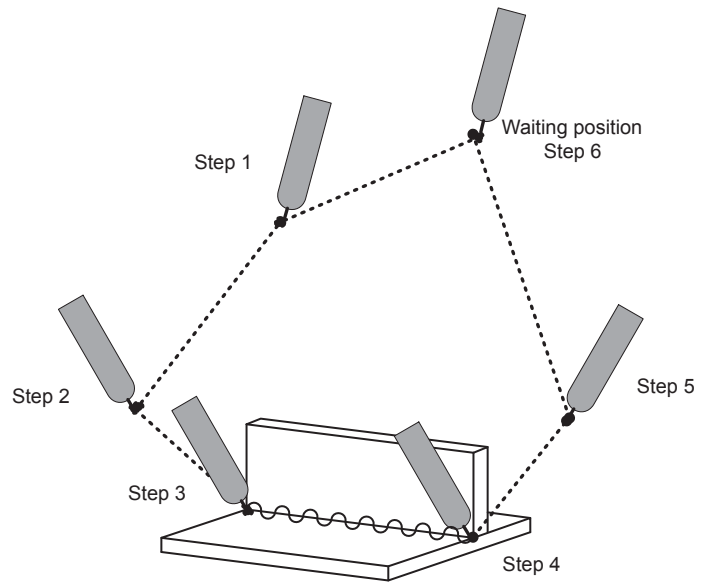

ARCOF

SUBSET	STANDARD	EXPANDED	APPLICATIONS
Available	Available	Available	Arc

Function

Outputs welding end command.

Construction

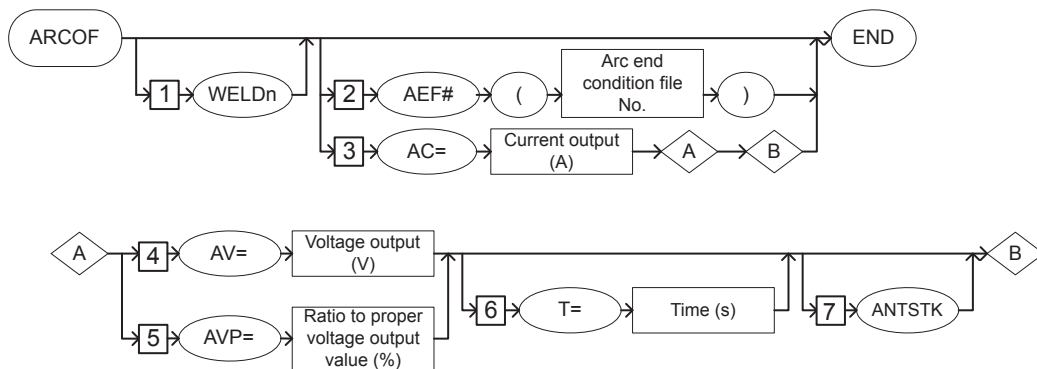

Explanation

1. WELDN

Choose one of the tags from the welder. These tags are valid for a system with multiple applications in which two or more arc welding applications are included. These tags are not displayed when there is only one application.

No	Tag	Explanation	Note
1	WELDN	Specifies the welder.	n: 1 to 8 WELD1: Welder 1

2.7 Arc Welding Instruction

2. AEF# (Arc end condition file number) /AC=Current output value

Choose one of the tags from the following table.

No	Tag	Explanation	Note
2	AEF#(Arc end condition file number)	Specifies the arc end condition file number. The condition when welding has ended is registered in the arc end condition file.	No.: 1 to 1000 Variable B//D/LB/LI/LD can be used.
3	AC=Current output value	Specifies the output value of the welding current.	Current value: 1 to 999A Variable B//D/B[]/I[]/D[]/LB/LI/LD/LB[]/LI[]/LD[] can be used.

3. AV=Voltage output value /AVP=Ratio to proper voltage output value

When AC=Current output value is selected from the table in part 2 of this Explanation, choose one of the tags from the following table.

No	Tag	Explanation	Note
4	AV=Voltage output value	Specifies the output value of the arc voltage. When the welder power supply is 'Individual' the output value of the arc voltage is specified.	Voltage value: 0.1 V to 50.0 V Variable B//D/B[]/I[]/D[]/LB/LI/LD/LB[]/LI[]/LD[] can be used. (Units: 0.1 V)
5	AVP=Ratio to proper voltage output value	Specifies the ratio to the aptitude output value of the arc voltage. When the welder power supply is 'Same' the ratio to the aptitude output value of the arc voltage is specified.	Ratio: 50% to 150% Variable B//D/B[]/I[]/D[]/LB/LI/LD/LB[]/LI[]/LD[] can be used.

4. T=Time

When AC=Current output value is selected from the table in part 2 of this Explanation, the following tag can be added or omitted.

No	Tag	Explanation	Note
6	T=Time	Specifies the timer value at welding end.	Time: 0.01 to 655.35 seconds Variable I/LI/I[]/LI[] can be used. (Units: 0.01 seconds)

2.7 Arc Welding Instruction

5. ANTSTK

When AC=Current output value is selected from the table in part 2 of this Explanation, the following tag can be added or omitted.

No	Tag	Explanation	Note
7	ANTSTK	Specifies the automatic sticking release function. The automatic wire sticking release function in which the wire sticking is released automatically. It puts out a constant voltage without outputting the wire sticking signal once wire sticking is detected.	Refer to the supplement "Automatic wire sticking release function".



Automatic wire sticking release function

The automatic wire sticking release function in which the wire sticking is released automatically. It puts out a constant voltage without outputting the wire sticking signal once wire sticking is detected. The condition of the frequency etc. of the wire sticking release processing is set in the auxiliary condition file.

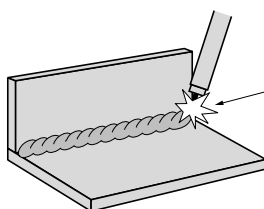

Automatic sticking release

Even if a single attempt has failed, the process is repeated up to the specified maximum repetition count.



For details of the automatic wire sticking release function, refer to the "Operator's Manual for Arc Welding".

2.7 Arc Welding Instruction

Example

(1) ARCOF AEF#(1)

The welding end condition is set in the arc end condition file No.1.

(2) NOP

MOVJ VJ=50.00

◆◆◆ Step 1

MOVL V=220

◆◆◆ Step 2

MOVL V=200

◆◆◆ Step 3

WVON WEV#(2)

◆◆◆ Weaving starts

ARCON AC=220 AVP=100 T=0.50

◆◆◆ Welding starts

MOVL V=138

◆◆◆ Step 4

ARCOF AC=160 AVP=90 T=0.50

◆◆◆ Welding ends

WVOF

◆◆◆ Weaving ends

MOVL V=200

◆◆◆ Step 5

MOVJ VJ=50.00

◆◆◆ Step 6

END

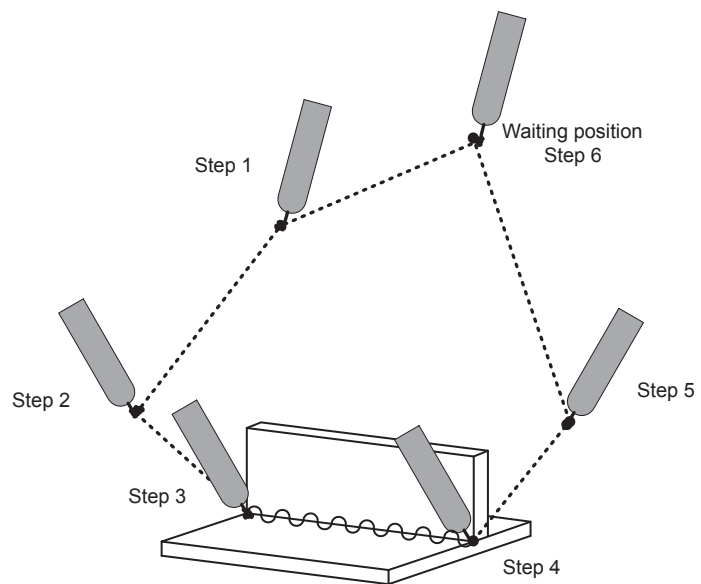

VWELD

SUBSET	STANDARD	EXPANDED	APPLICATIONS
Available	Available	Available	Arc

Function

Sets the arc voltage by the voltage command value.

Construction

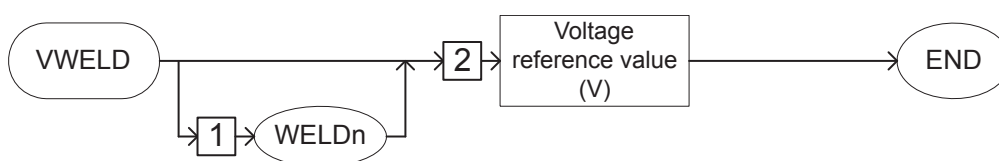

Explanation

1. WELDn

Choose one of the tags from the welder. These tags are valid for a system with multiple applications in which two or more arc welding applications are included. These tags are not displayed when there is only one application.

No	Tag	Explanation	Note
1	WELDn	Specifies the welder.	n: 1 to 8 WELD1: Welder 1

2. Voltage command value

Specifies the command value of the arc voltage.

No	Tag	Explanation	Note
2	Voltage command value	Specifies the command value of the arc voltage. This is a command value of the voltage which is transmitted from the controller to the welder to output the welding voltage from the welder. The relation between the command welding voltage and the output value is different depending on the model of the welder.	Command value: -14.00 V to +14.00 V Variable I/LI/I[]/LI[] can be used. (Units: 0.01 V)



For details of the output characteristics of the welder, refer to the "Operator's Manual for Arc Welding".

2.7 Arc Welding Instruction

Example

(1) VWELD 6.0

The command value of the arc voltage is set to 6.0V.

AWELD

SUBSET	STANDARD	EXPANDED	APPLICATIONS
Available	Available	Available	Arc

Function

Sets the welding current by the current command position.

Construction

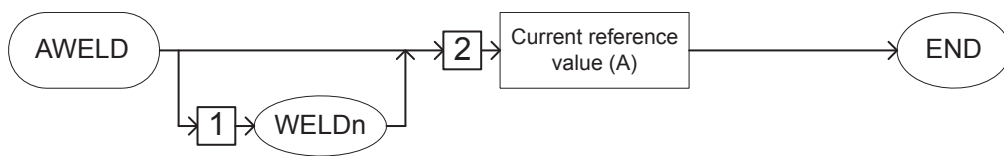

Explanation

1. WELDN

Choose one of the tags from welder. These tags are valid for a system with multiple applications in which two or more arc welding applications are included. These tags are not displayed when there is only one application.

No	Tag	Explanation	Note
1	WELDN	Specifies the welder.	n: 1 to 8 WELD1: Welder 1

2. Current command value

Specifies the command value of the welding current.

No	Tag	Explanation	Note
2	Voltage command value	Specifies the command value of the welding current. This is a command value of the current which is transmitted from the controller to the welder to output the welding current from the welder. The relation between the command welding current and the output value is different depending on the model of the welder.	Command value: -14.00 V to +14.00 V Variable I/LI/I[]/LI[] can be used. (Units: 0.01 V)



For details of the output characteristics of the welder, refer to the "Operator's Manual for Arc Welding".

2.7 Arc Welding Instruction

Example

(1) AWELD 6.0

The command value of the welding current is set to 6.0V.

ARCSET

SUBSET	STANDARD	EXPANDED	APPLICATIONS
Available	Available	Available	Arc

Function

Sets and changes each welding condition individually.

Construction

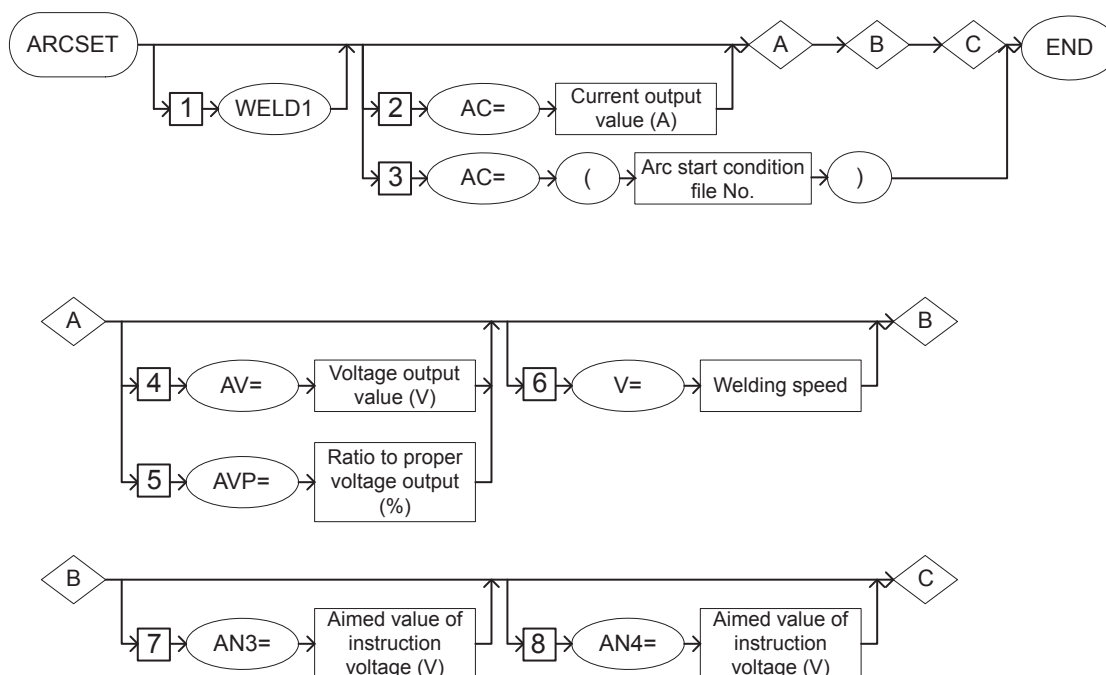

Explanation

1. WELDn

Choose one of the tags from welder. These tags are valid for a system with multiple applications in which two or more arc welding applications are included. These tags are not displayed when there is only one application.

No.	Tag	Explanation	Note
1	WELDn	Specifies the welder.	n: 1 to 8 WELD1: Welder 1

2.7 Arc Welding Instruction

2. AC=Current output value / ASF#(Arc start condition file number)

The following tag can be added or omitted.

No.	Tag	Explanation	Note
2	AC=Current output value	Specifies the output value of the welding current.	Current value: 1 to 999 A Variable B/I/D/B[]/I[]/D[]/ LB/LI/LD/LB[]/LI[]/LD[] can be used.
3	ASF#(Arc start condition file number)	Specifies the arc start condition file number. The condition when the welding begins is registered in the arc start condition file.	No: 1 to 1000 Variable B/I/D/LB/LI/LD can be used.

3. AV=Voltage output value/AVP=Ratio to proper voltage output value

Choose one of the tags from the following table.

No.	Tag	Explanation	Note
4	AV=Voltage output value	Specifies the output value of the arc voltage. When the welder power supply is 'Individual', the output value of the arc voltage is specified.	Voltage value: 0.1V to 50.0 V Variable B/I/D/B[]/I[]/D[]/ LB/LI/LD/LB[]/LI[]/LD[] can be used. (Units: 0.1V)
5	AVP=Ratio to proper voltage output value	Specifies the ratio to the aptitude output value of the arc voltage. When the welder power supply is 'Same', the ratio to the aptitude output value of the arc voltage is specified.	Ratio: 50% to 150% Variable B/I/D/B[]/I[]/D[]/ LB/LI/LD/LB[]/LI[]/LD[] can be used.

4. V=Welding speed

The following tag can be added or omitted.

No.	Tag	Explanation	Note
6	V=Welding speed	Specifies the speed while welding. Specifies the unit of rate using the operation condition setting screen.	Speed: 0.1 mm to 1500.0 mm/s. Setting the parameter S2C101 can change the units. Variable B/I/D/B[]/I[]/D[]/ LB/LI/LD/LB[]/LI[]/LD[] can be used. (Units: 0.1 mm/s)

DX100

2.7 Arc Welding Instruction

5. AN3=Aimed value of instruction voltage

The following tag can be added or omitted.

No.	Tag	Explanation	Note
7	AN3=Aimed value of instruction voltage	Specifies the aimed value of the instruction voltage to analog output 3.	Aimed value: -14.00 V to +14.00 V Variable I/LI/I[]/LI[] can be used. (Units: 0.01 V)

6. AN4=Aimed value of instruction voltage

The following tag can be added or omitted.

No.	Tag	Explanation	Note
8	AN4=Aimed value of instruction voltage	Specifies the aimed value of the instruction voltage to analog output 4.	Aimed value: -14.00 V to +14.00 V Variable I/LI/I[]/LI[] can be used. (Units: 0.01 V)

Example

(1) NOP	
MOVJ VJ=50.00	*** Step 1
MOVJ VJ=80.00	*** Step 2(Arc start position)
ARCON AC=200 AVP=100 T=0.30	*** Arc starts
MOVL V=50	*** Step 3
MOVL V=50	*** Step 4
ARCSET AC=250	*** Changes the welding condition (AC=200 → AC=250)
MOVL V=65	
ARCOF	*** Step 5
MOVJ VJ=50.00	*** Welding ends
MOVJ VJ=100.00	*** Step 6
END	*** Step 7

WVON

SUBSET	STANDARD	EXPANDED	APPLICATIONS
Available	Available	Available	Arc, general-purpose, and laser welding

Function

Starts weaving operation.

Construction

The tags to be added differ depending on the control group in the job.

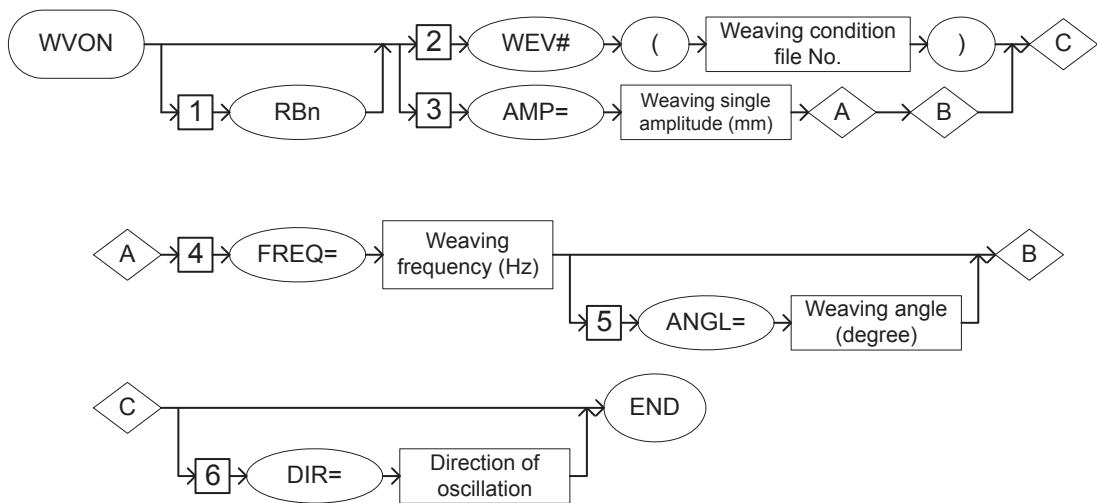

Table 2-19: Job Type and Control Group

No.	Job Type	Control Group	Remarks
1	Single	One manipulator (standard)	
2	Coordinated	Two manipulators	Optional

Table 2-20: Availability of Each Tag

No	Tag	Control Group		Note
		1	2	
1	RBn	x	•	
2	WEV#()	•	•	
3	AMP=	•	•	
4	FREQ=	•	•	
5	ANGL=	•	•	
6	DIR=	•	•	

•: Available
x: Not available

2.7 Arc Welding Instruction

Explanation

1. RBn

Choose one of the tags from the following table.

No	Tag	Explanation	Note
1	RBn	Specifies the robot that is to execute a weaving operation.	n: 1 to 8 RB1: Robot 1

2. WEV# (Weaving condition file number)/
AMP=Weaving single amplitude

Choose one of the tags from the following table.

No	Tag	Explanation	Note
2	WEV#(Weaving condition file number)	Specifies the weaving condition file number. The condition when the weaving operates is registered in the weaving condition file.	No.: 1 to 255 Variable B/I/D/LB/LI/LD can be used.
3	AMP=Weaving signal amplitude	Specifies the amplitude of oscillation for weaving.	Single amplitude: 0.1 mm to 99.9 mm Variable B/B[]/LB/LB[]/I/I[]/LI/LI[]/D/D[]/LD/LD[] can be used. (Units: 0.1 mm)

3. FREQ=Weaving frequency

When AMP=Weaving single amplitude is selected from the table in part 2 of this Explanation, add the following tag.

No	Tag	Explanation	Note
4	FREQ=Weaving frequency	Specifies the weaving frequency.	Frequency: 1.0 Hz to 5.0 Hz Variable B/I/D/B[]/I[]/D[]/LB/LI/LD/LB[]/LI[]/LD[] can be used. (Units: 0.1 Hz)

4. ANGL=Weaving angle

When AMP=Weaving single amplitude is selected from the table in part 2 of this Explanation, the following tag can be added or omitted after the tag FREQ=Weaving frequency is selected from the table in part 3 of this Explanation.

No	Tag	Explanation	Note
5	ANGL=Weaving angle	Specifies the weaving angle.	Angle: 0.1 deg. to 180.0 deg. Variable B/I/D/B[]/I[]/D[]/LB/LI/LD/LB[]/LI[]/LD[] can be used. (Units: 0.1 deg.)

2.7 Arc Welding Instruction

5. DIR=Direction of oscillation

The following tag can be added or omitted.

No	Tag	Explanation	Note
6	DIR=Direction of oscillation	Specifies the direction of oscillation. Refer to the supplement "Weaving conditions".	Direction: 0 or 1 0: Forward 1: Reversed Variable B/I/D/B[]/I[]/D[]/ LB/LI/LD/LB[]/LI[]/LD[] can be used.

2.7 Arc Welding Instruction



Wearing conditions

- Weaving single amplitude
Set the amplitude of oscillation.

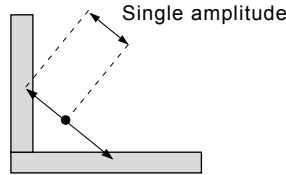

- Weaving angle
Set the angle of oscillation.

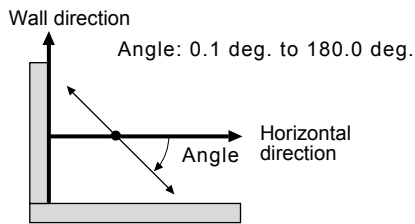

Weaving mode: Single oscillation

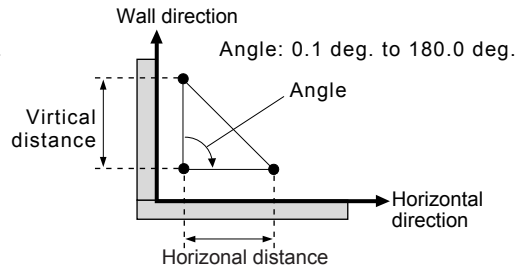

Weaving mode: Triangular or L-shape oscillation

- Direction of oscillation
The directions, "forward" and "reversed", are defined as follows. Set "0 (forward)" or "1 (reversed)" for the direction of oscillation.

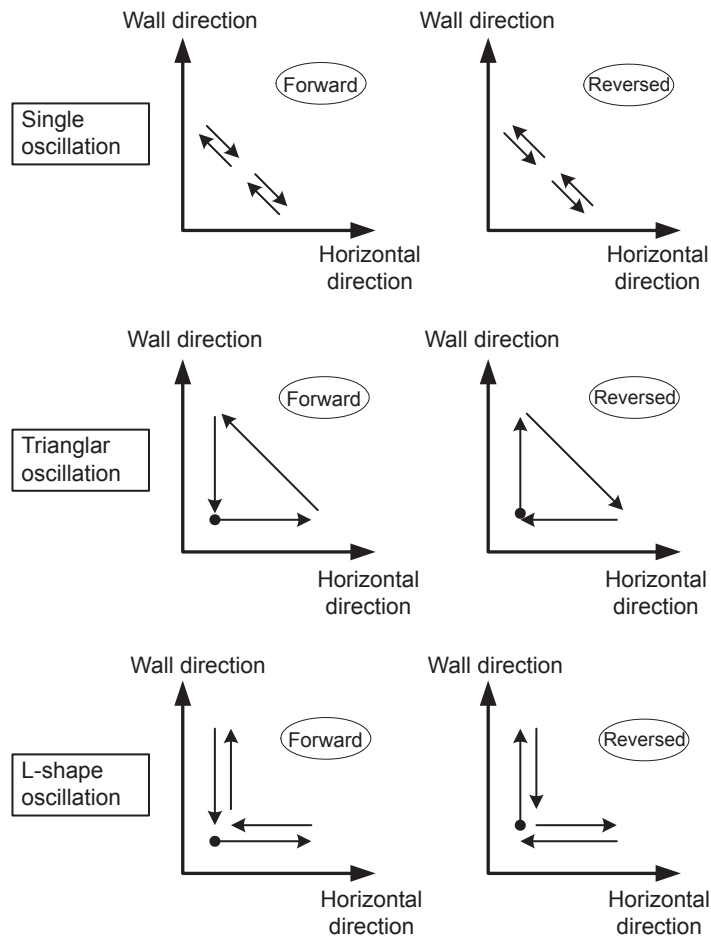

2.7 Arc Welding Instruction



For details of the weaving condition file number, refer to the "Operator's Manual for the Arc Welding".

Example

(1) WVON WEV#(1) DIR=1

Weaving starts with the conditions specified in the weaving condition file.

(2) NOP

MOVJ VJ=50.00

◆◆◆ Step 1

MOVL V=220

◆◆◆ Step 2

MOVL V=200

◆◆◆ Step 3

WVON AMP=5.0 FREQ=3.0 ANGL40.0

◆◆◆ Weaving starts

ARCON AC=220 AVP=100 T=0.5

◆◆◆ Welding starts

MOVL V=138

◆◆◆ Step 4

ARCOF AC=160 AVP=90 T=0.50

◆◆◆ Welding ends

WVOF

◆◆◆ Weaving ends

MOVL V=200

◆◆◆ Step 5

MOVJ VJ=50.00

◆◆◆ Step 6

END

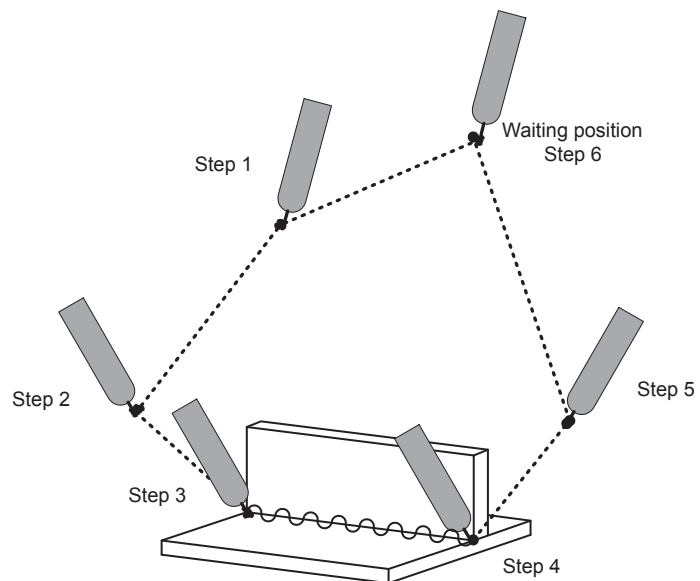

WVOF

SUBSET	STANDARD	EXPANDED	APPLICATIONS
Available	Available	Available	Arc, general-purpose, and laser welding

Function

Ends weaving operation.

Construction

The tags to be added differ depending on the control group in the job.



Table 2-21: Job Type and Control Group

No.	Job Type	Control Group	Remarks
1	Single	One manipulator (standard)	
2	Coordinated	Two manipulators	Optional

Table 2-22: Availability of Each Tag

No	Tag	Control Group		Note
		1	2	
1	RBn	x	•	

●: Available
x: Not available

2.7 Arc Welding Instruction

Explanation

1. RBn

Choose one of the tags from the following table.

No	Tag	Explanation	Note
1	RBn	Specifies the robot that is to end the weaving operation.	n: 1 to 8 RB1: Robot 1

Example

```

(1) NOP
MOVJ VJ=50.00          *** Step 1
MOVL V=220             *** Step 2
MOVL V=200             *** Step 3
WVON WEV#(2)          *** Weaving starts
ARCON AC=220 AVP=100 T=0.50 *** Welding starts
MOVL V=138            *** Step 4
ARCOF AC=160 AVP=90 T=0.50 *** Welding ends
WVOF                  *** Weaving ends
MOVL V=200            *** Step 5
MOVJ VJ=50.00        *** Step 6
END

```

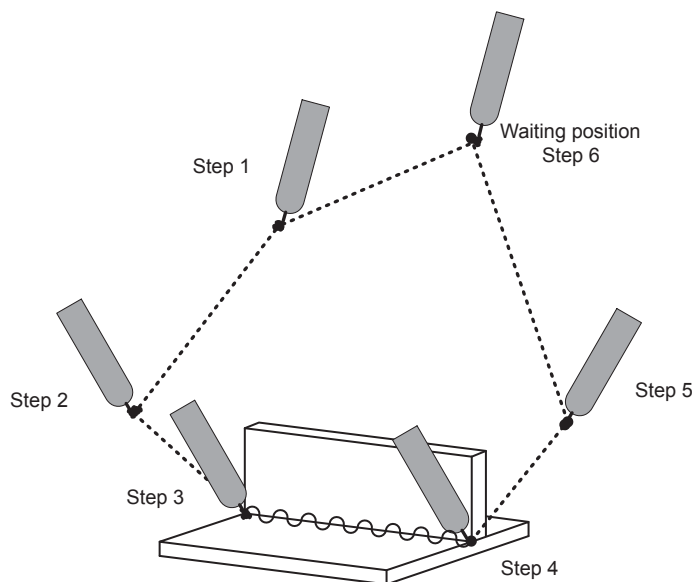

ARCCTS

SUBSET	STANDARD	EXPANDED	APPLICATIONS
Available	Available	Available	Arc

Function

Controls the welding current and the voltage in the specified starting section.

This function is used with the move instruction. The current and the voltage are changed while the robot is moving. The aimed value and section have to be set. The section is specified as a distance from the moving start point. If it is not specified, it is regarded as the entire section of the move instruction.

Construction

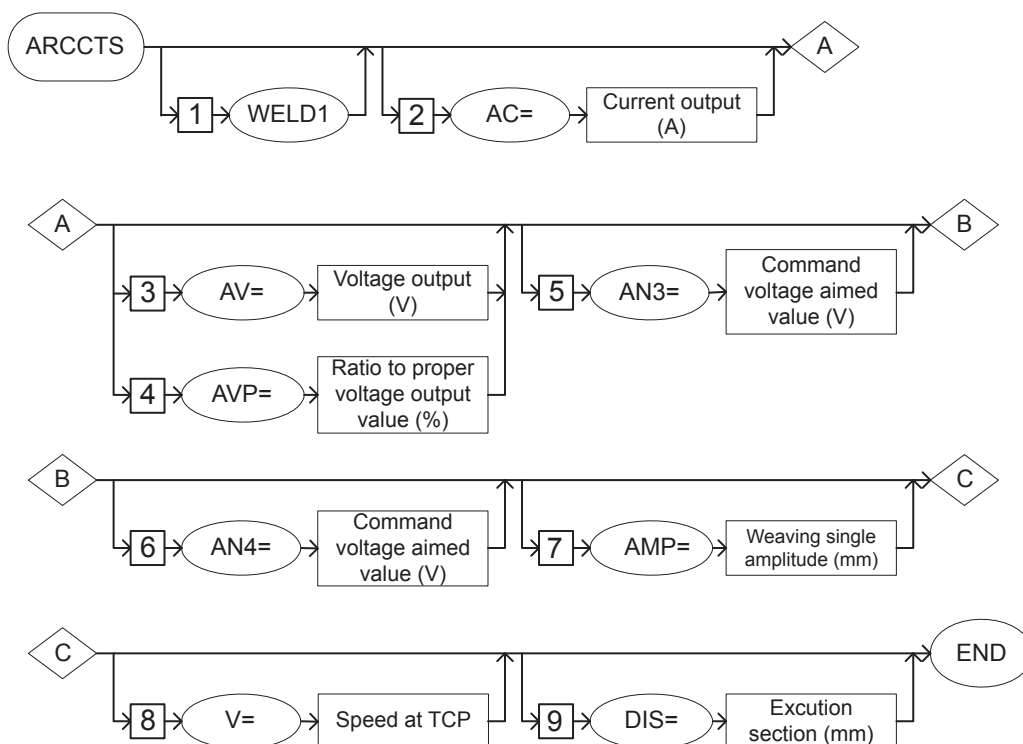

2.7 Arc Welding Instruction

Explanation

1. WELDn

Choose one of the tags from welder. These tags are valid for a system with multiple applications in which two or more arc welding applications are included. These tags are not displayed when there is only one application.

No	Tag	Explanation	Note
1	WELDn	Specifies the welder.	n: 1 to 8 WELD1: Welder 1

2. AC=Current output value

The following tag can be added or omitted.

No	Tag	Explanation	Note
2	AC=Current output value	Specifies the aimed value of the welding current.	Current value: 1 to 999A Variable B/I/D/B[]/I[]/D[]/LB/LI/LD/LB[]/LI[]/LD[] can be used.

3. AV=Voltage output value /AVP=Ratio to proper voltage output value

Choose one of the tags from following table.

No	Tag	Explanation	Note
3	AV=Voltage output value	Specifies the aimed value of the welding voltage.	Voltage value: 0.1 V to 50.0 V Variable B/I/D/B[]/I[]/D[]/LB/LI/LD/LB[]/LI[]/LD[] can be used. (Units: 0.1 V)
4	AVP=Ratio to proper voltage output value	Specifies the aimed value for the welding voltage in the ratio to the proper voltage output value.	Ratio: 50% to 150% Variable B/I/D/B[]/I[]/D[]/LB/LI/LD/LB[]/LI[]/LD[] can be used.

4. AN3=Aimed value of instruction voltage

The following tag can be added or omitted.

No	Tag	Explanation	Note
5	AN3=Aimed value of instruction voltage	Specifies the aimed value of the instruction voltage to analog output 3.	Aimed value: -14.00 V to +14.00 V Variable I/I[]/L/LI[] can be used. (Units: 0.01 V)

DX100

2.7 Arc Welding Instruction

5. AN4=Aimed value of instruction voltage

The following tag can be added or omitted.

No	Tag	Explanation	Note
6	AN4=Aimed value of instruction voltage	Specifies the aimed value of the instruction voltage to analog output 4.	Aimed value: -14.00 V to +14.00 V Variable I/I[]/L/LI[] can be used. (Units: 0.01 V)

6. AMP=Weaving signal amplitude

The following tag can be added or omitted.

No	Tag	Explanation	Note
7	AMP=Weaving signal amplitude	Specifies the amplitude of oscillation for weaving.	Single amplitude: 0.1 mm to 99.9 mm Variable B/B[]/LB/LB[]/I/I[]/L/LI[]/D/D[]/LD/LD[] can be used. (Units: 0.1 mm)

7. V=Tool center point speed

The following tag can be added or omitted.

No	Tag	Explanation	Note
8	V=Tool center point speed	Specifies the Tool center point speed.	Speed: 0.1 mm to 1500.0 mm/s The units can be changed by setting the parameter S2C173. Variable B/B[]/LB/LB[]/I/I[]/L/LI[]/D/D[]/LD/LD[] can be used. (Units: 0.1 mm/s)

8. DIS=Execution section

The following tag can be added or omitted.

No	Tag	Explanation	Note
9	DIS=Execution section	Specifies the execution section where the current and the voltage are changed. The execution section is set by the distance from the moving start point. If the section is not specified, all the section of the move instruction is regarded as the execution section.	Section: 0.1 mm to 6553.5 mm Variable B/I/D/B[]/I[]/D[]/LB/LI/LD/LB[]/LI[]/LD[] can be used. (Units: 0.1 mm)

2.7 Arc Welding Instruction



Slope up/down function

The slope up/down function allows for the current and the voltage value etc., during welding to be gradually changed.

This function is used when the base metal is a board, or when the object is an aluminum which has high heat conductivity.

In this function, the ARCCTS and the ARCCTE instruction are used.

For details of the slope up/down function, refer to the "Operator's Manual for the Arc Welding".

Example

- (1) ARCCTS AC=150 AV=16.0 DIS=100.0
MOVL V=80

To make the welding current =150A and arc voltage =16V, the current and the voltage are changed in the section of 100mm from the move start point.

Gradually Decreasing Current or Voltage

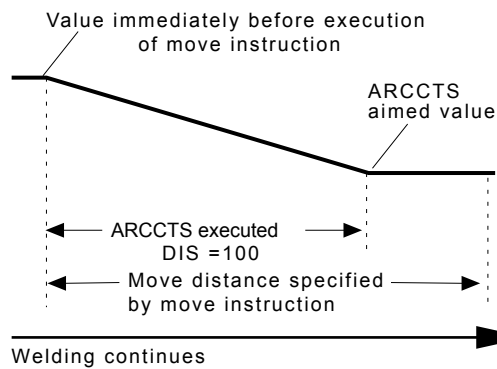

Gradually Increasing Current or Voltage

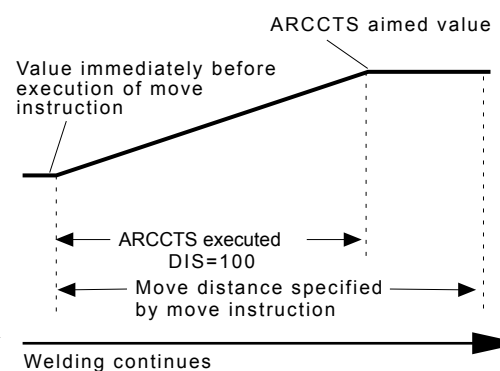

- (2) ARCCTS AC=150 AV=16.0 AN3=7.50 AN4=6.50 DIS=100.0

To make the welding current =150A, arc voltage =16V, aimed value =7.5V of the instruction voltage to analog output 3, and aimed value =6.5V of the instruction voltage to analog output 4, the current and the voltage are changed in the section of 100mm from the move start point.

ARCCTE

SUBSET	STANDARD	EXPANDED	APPLICATIONS
Available	Available	Available	Arc

Function

Controls the welding current and the voltage in the specified end section.

This function is used with the move instruction and modifies the current and the voltage while the manipulator is moving. The aimed value and the section are set. The section is specified as a distance from the moving end point. If it is not specified, it is regarded as the entire section of the move instruction.

Construction

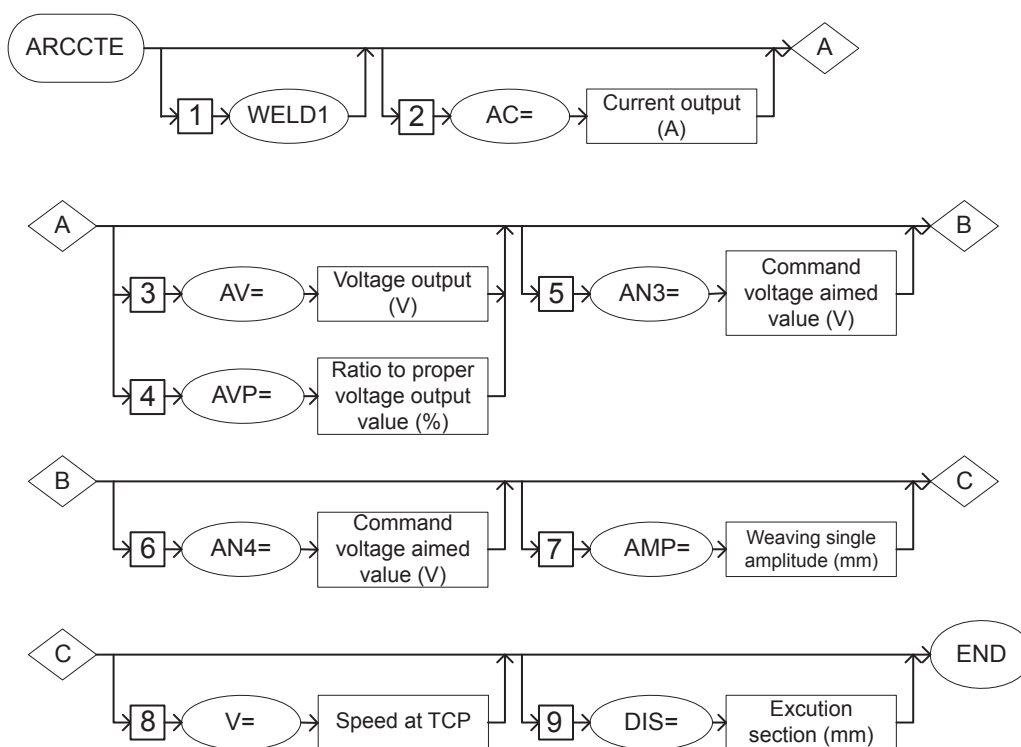

2.7 Arc Welding Instruction

Explanation

1. WELDn

Choose one of the tags from the following table. These tags are valid for a system with multiple applications in which two or more arc welding applications are included. These tags are not displayed when there is only one application.

No	Tag	Explanation	Note
1	WELDn	Specifies the welder.	n: 1 to 8 WELD1: Welder 1

2. AC=Current output value

The following tag can be added or omitted.

No	Tag	Explanation	Note
2	AC=Current output value	Specifies the aimed value of the welding current.	Current value: 1 to 999A Variable B//D/B[]/I[]/D[]/ LB/LI/LD/LB[]/LI[]/LD[] can be used.

3. AV=Voltage output value /AVP=Ratio to proper voltage output value

Choose one of the tags from the following table.

No	Tag	Explanation	Note
3	AV=Voltage output value	Specifies the aimed value of the welding voltage.	Voltage value: 0.1 V to 50.0 V Variable B//D/B[]/I[]/D[]/ LB/LI/LD/LB[]/LI[]/LD[] can be used. (Units: 0.1 V)
4	AVP=Ratio to proper voltage output value	Specifies the aimed value for the welding voltage in the ratio to the proper voltage output value.	Ratio: 50% to 150% Variable B//D/B[]/I[]/D[]/ LB/LI/LD/LB[]/LI[]/LD[] can be used.

4. AN3=Aimed value of instruction voltage

The following tag can be added or omitted.

No	Tag	Explanation	Note
5	AN3=Aimed value of instruction voltage	Specifies the aimed value of the instruction voltage to analog output 3.	Aimed value: -14.00 V to +14.00 V Variable I/I[]/LI/LI[] can be used. (Units: 0.01 V)

DX100

2.7 Arc Welding Instruction

5. AN4=Aimed value of instruction voltage

The following tag can be added or omitted.

No	Tag	Explanation	Note
6	AN4=Aimed value of instruction voltage	Specifies the aimed value of the instruction voltage to analog output 4.	Aimed value: -14.00 V to +14.00 V Variable I/I[]/L/LI[] can be used. (Units: 0.01 V)

6. AMP=Weaving signal amplitude

The following tag can be added or omitted.

No	Tag	Explanation	Note
7	AMP=Weaving signal amplitude	Specifies the amplitude of oscillation for weaving.	Single amplitude: 0.1 mm to 99.9 mm Variable B/B[]/LB/LB[]/I/I[]/L/LI[]/D/D[]/LD/LD[] can be used. (Units: 0.1 mm)

7. V=Tool center point speed

The following tag can be added or omitted.

No	Tag	Explanation	Note
8	V=Tool center point speed	Specifies the Tool center point speed.	Speed: 0.1 mm to 1500.0 mm/s The units can be changed by setting the parameter S2C173. Variable B/B[]/LB/LB[]/I/I[]/L/LI[]/D/D[]/LD/LD[] can be used. (Units: 0.1 mm/s)

8. DIS=Execution section

The following tag can be added or omitted.

No	Tag	Explanation	Note
9	DIS=Execution section	Specifies the execution section where the current and the voltage are modified. The execution section is set by the distance from the moving start point. If the section is not specified, the entire section of the move instruction is regarded as the execution section.	Section: 0.1 mm to 6553.5 mm Variable B/I/D/B[]/I[]/D[]/LB/LI/LD/LB[]/L[]/LD[] can be used. (Units: 0.1 mm)

2.7 Arc Welding Instruction



For details of the slope up/down function, refer to the "Operator's Manual for the Arc Welding".

Example

(1) ARCCTE AC=150 AV=16.0 DIS=100.0

MOVL V=80

To make the welding current =150A and arc voltage =16V, the current and the voltage are changed in the section of 100mm from the move end point.

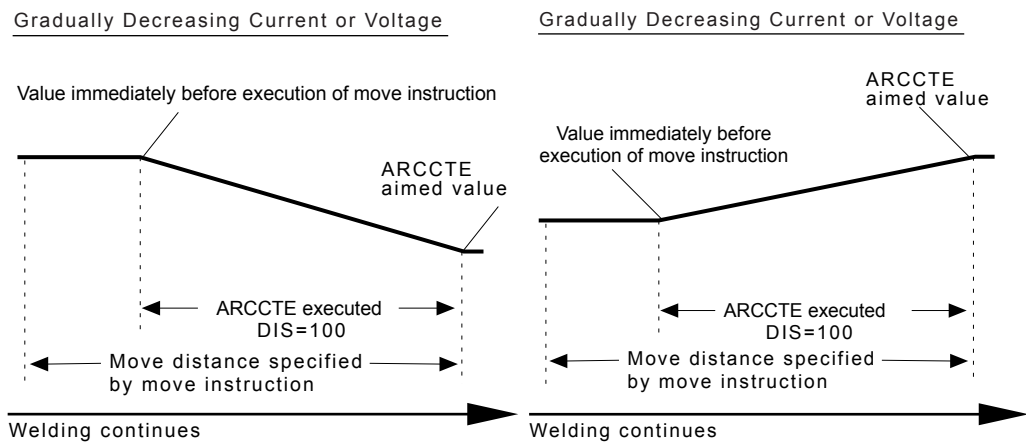

(2) ARCCTE AC=150 AV=16.0 AN3=7.50 AN4=6.50 DIS=100.0

To make the welding current =150A, arc voltage =16V, aimed value =7.5V of the instruction voltage to analog output 3, and aimed value =6.5V of the instruction voltage to analog output 4, the current and the voltage are changed in the section of 100mm from the move end point.

2.8 Handling Instruction

HAND

SUBSET	STANDARD	EXPANDED	APPLICATIONS
Available	Available	Available	Handling

Function

Turns the signal to the tool valve ON or OFF to control the tool.

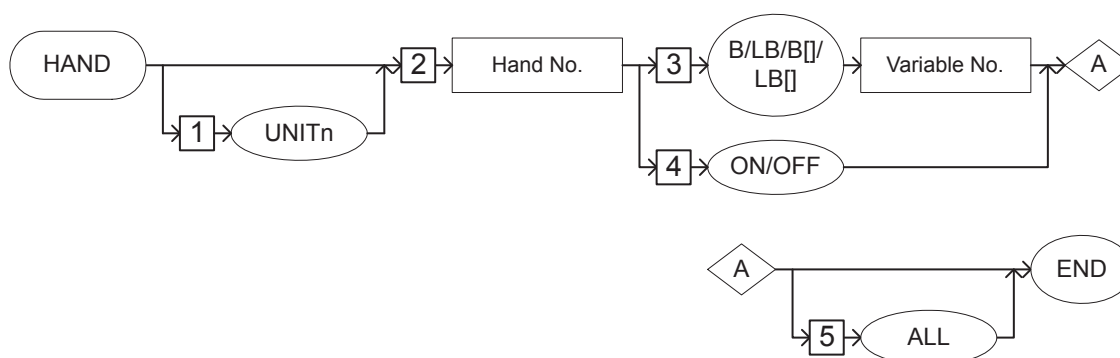
Construction**Explanation**

1. UNITn

Choose one of the tags from the Device. These tags are valid for a system with multiple applications in which two or more handling applications are included. These tags are not displayed when there is only one application.

No	Tag	Explanation	Note
1	UNITn	Specifies the Device No.	n: 1 to 8 UNIT1: Device 1

2. Hand number

Add the following tag.

No	Tag	Explanation	Note
2	Hand number	Specifies the hand number.	No.: 1 to 4 Variable B//D/LB/LI/LD can be used.

2.8 Handling Instruction

3. B Variable number/LB Variable number/B [Array number]/LB [Array number]/ON/OFF

Choose one of the tags from the following table.

No	Tag	Explanation	Note
3	B Variable number/ LB Variable number/ B [Array number]/ LB [Array number]	Refers the least significant bit of the specified byte type variable to specify the ON/OFF status of the signal to be sent to the tool valve.	Least significant bit: 0: OFF 1: ON
4	ON/OFF	Specifies the ON/OFF status of the signal to be sent to the tool valve.	

4. ALL

The following tag can be added or omitted.

No	Tag	Explanation	Note
5	ALL	Specifies the simultaneous control of Valve 1 and Valve 2.	Used when a 3P solenoid is used.

Example

HAND 1 OFF

Turns OFF the signal output to tool valve 1.

HSEN

SUBSET	STANDARD	EXPANDED	APPLICATIONS
Available	Available	Available	Handling

Function

Monitors the input status of the tool sensor. Stores the result in the system variable \$B006.



For details of system variables, refer to GETS of Section 2.3 "Operating Instruction" on page 2-70.

Construction

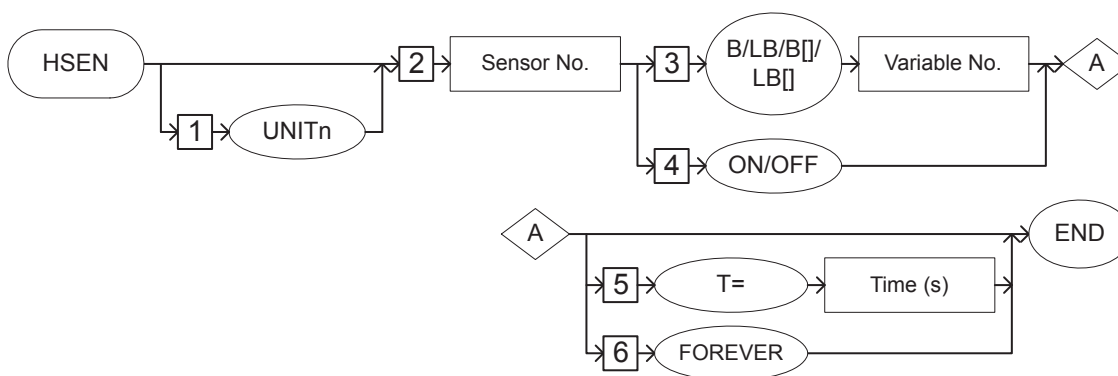

Explanation

1. UNITn

Choose one of the tags from the following table. These tags are valid for a system with multiple applications in which two or more handling applications are included. These tags are not displayed when there is only one application.

No	Tag	Explanation	Note
1	UNITn	Specifies the Device No.	

2. Sensor number

Add the following tag.

No	Tag	Explanation	Note
2	Sensor number	Specifies the sensor number.	No.: 1 to 8 Variable B/I/D/LB/LI/LD can be used.

2.8 Handling Instruction

3. B Variable number/LB Variable number/B [Array number]/LB [Array number]/ON/OFF

Choose one of the tags from the following table.

No	Tag	Explanation	Note
3	B Variable number/ LB Variable number/ B [Array number]/ LB [Array number]	Refers the least significant bit of the specified byte type variable to specify the ON/OFF status of the monitoring input status of the tool sensor.	Least significant bit: 0: OFF 1: ON
4	ON/OFF	Specifies the ON/OFF status of the monitor input of the tool sensor.	

4. T=Time/FOREVER

Choose one of the tags from the following table.

No	Tag	Explanation	Note
5	T=Time	Specifies the time for monitoring the input status.	Units: seconds Variable I/LI/I[]/LI[] can be used. (Units: 0.01 seconds)
6	FOREVER	Specifies monitoring without a time limit.	

Example

HSEN 1 ON

Checks if sensor 1 is ON at the execution of an HSEN instruction and stores the result in the system variable \$B006.

1 is stored in \$B006 when sensor 1 is ON, 0 is stored when sensor 1 is OFF.

2.9 Spot Welding Instruction

GUNCL

SUBSET	STANDARD	EXPANDED	APPLICATIONS
Available	Available	Available	Spot

Function

Applies pressure to the air gun.

Construction

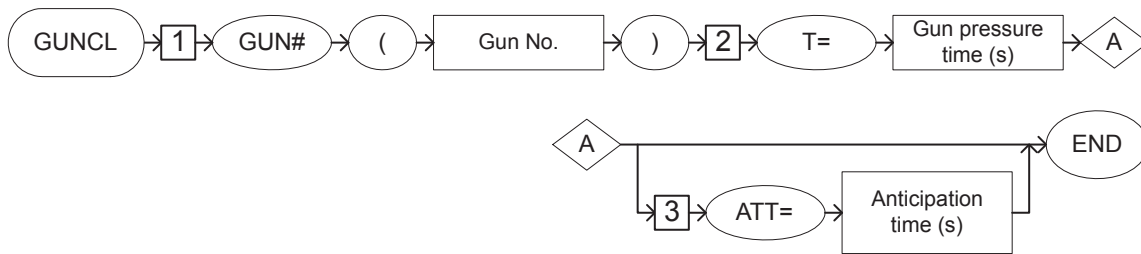

Explanation

1. GUN# (Gun number)

Add the following tag.

No	Tag	Explanation	Note
1	GUN# (Gun number)	Specifies the number of the air gun to which pressure is applied.	No.: 1 to 8 Variable B/I/D/LB/LI/LD can be used.

2. T=Time

Add the following tag.

No	Tag	Explanation	Note
2	T=Gun pressure time	Specifies the time during which the air gun is closed.	Units: seconds Variable I/LI/I[]/LI[] can be used. (Units: 0.01 seconds)

2.9 Spot Welding Instruction

3. ATT= Anticipation time

The following tag can be added or omitted.

No	Tag	Explanation	Note
3	ATT=Anticipaton time	Specifies the anticipation time for which the execution of the GUNCL instruction is advanced. The GUNCL instruction is carried out in advance for the specified time before reaching the step immediately before the GUNCL instruction. An NWAIT tag must be added to the move instruction of the step immediately before the GUNCL instruction.	Units: seconds Variable I/LI/I[]/LI[] can be used. (Units: 0.01 seconds)

Example

```

MOV L V=1000 NWAIT          *** Step 5
GUNCL GUN#(1) T=2.00 ATT=0.50

```

Turns ON the Gun 1 pressure signal 0.5 seconds before the manipulator reaches Step 5, and turns it OFF 2 seconds later (1.5 seconds after the manipulator reaches Step 5).

2.9 Spot Welding Instruction

SPOT

SUBSET	STANDARD	EXPANDED	APPLICATIONS
Available	Available	Available	Spot

Function

Starts the welding sequence after pressure has been applied to the air gun.

Construction

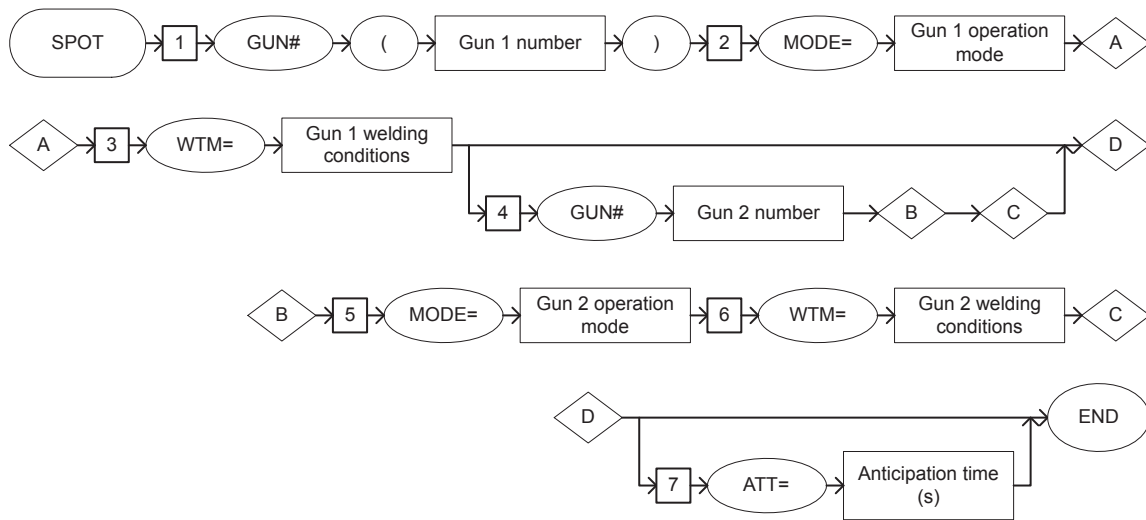

Explanation

1. GUN# (Gun 1 number)

Add the following tag.

No	Tag	Explanation	Note
1	GUN# (Gun 1 number)	Specifies the number of the air gun to be used for welding. For a 2-gun system, specify the number of the first air gun.	No.: 1 to 8 Variable B//D/LB/LI/LD can be used.

2. MODE=Gun 1 operation mode

Add the following tag.

No	Tag	Explanation	Note
2	MODE=Gun 1 operation mode	Specifies the operation mode of the air gun. For a 2-gun system, specify the operation mode of the first air gun.	Mode: 0 to 4 Variable B/B[]/LB/LB[]//I[]/LI/LI[]/D/D[]/LD/LD[] can be used.

2.9 Spot Welding Instruction

**Gun operation mode**

The following table lists the settings and their operation modes.

For a 2-step stroke gun, make the settings according to the open status before and after welding.

Setting	Before Welding → After Welding
0	Single gun
1	Short open → Short open
2	Short open → Full open
3	Full open → Short open
4	Full open → Full open

3. WTM=Gun 1 welding condition

Add the following tag.

No	Tag	Explanation	Note
3	WTM=Gun 1 welding condition	Specifies the welding condition number set for the welder. For a 2-gun welding system, set the welding condition number of the first air gun.	Condition No.: 1 to 255 Variable B/B[]/LB/LB[]/I/ I[]/L/LI[]/D/D[]/LD/LD[] can be used.

4. GUN# (Gun 2 number)

The following tag can be added or omitted.

No	Tag	Explanation	Note
4	Gun 2 number	Specifies the number of the air gun used for welding. For a 2-gun welding system, specify the number of the second air gun.	No.: 1 to 8 Variable B//D/LB/LI/LD can be used.

5. MODE=Gun 2 operation mode

When a Gun 2 number (GUN#) is selected from the table in part 4 of this Explanation, add the following tag.

No	Tag	Explanation	Note
5	MODE=Gun2 operation mode	Specifies the operation mode of the air gun. For a 2-gun welding system, specify the operation mode of the second air gun.	Mode: 0 to 4 Variable B/B[]/LB/LB[]/I/ I[]/L/LI[]/D/D[]/LD/LD[] can be used.

2.9 Spot Welding Instruction

6. WTM=Gun 2 welding condition

When a Gun 2 number (GUN#) is selected from the table in part 4 of this Explanation, add the following tag after MODE=Gun 2 operation mode is selected from the table in part 5 of this Explanation.

No	Tag	Explanation	Note
6	WTM=Gun 2 welding condition	Specifies the welding condition number set for the welder. For a 2-gun welding system, specify the welding condition number for the second air gun.	Condition No.: 1 to 255 Variable B/B[]/LB/LB[]/I/I[]/LI/LI[]/D/D[]/LD/LD[] can be used.

7. ATT=Anticipation time

The following tag can be added or omitted.

No	Tag	Explanation	Note
7	ATT=Anticipation time	Specifies the anticipation time for which the execution of the SPOT instruction is advanced. The SPOT instruction is carried out in advance for the specified time before reaching the step immediately before the SPOT instruction. An NWAIT tag must be added to the move instruction of the step immediately before the SPOT instruction.	Units: seconds Variable I/I[]/LI/LI[] can be used. (Units: 0.01 seconds)

Example

```
MOVL V=1000 NWAIT                               ◆◆◆ Step 5
SPOT GUN#(1) MODE=2 WTM=5 ATT=0.50
```

0.5 seconds before the manipulator reaches Step 5, the spot welding sequence starts from the moment the air gun is short open, and the air gun is full open after the sequence is completed. Then the manipulator carries out the next step.

STROKE

SUBSET	STANDARD	EXPANDED	APPLICATIONS
Available	Available	Available	Spot

Function

Switches the open status of the 2-step stroke gun to/from Full open to/from Short open when not welding.

Construction

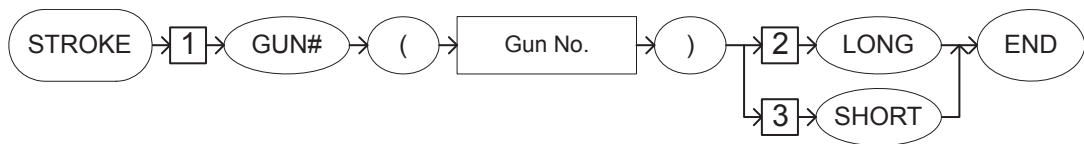

Explanation

1. GUN# (Gun number)

Add the following tag.

No	Tag	Explanation	Note
1	Gun# (Gun number)	Specifies the number of the air gun whose open status is to be changed.	No.: 1 to 8 Variable B//D/LB/LI/LD can be used.

2. LONG/SHORT

Choose one of the tag from the following table.

No	Tag	Explanation	Note
2	LONG	Specifies Full open.	
3	SHORT	Specifies Short open.	

Example

```
MOVL V=1000 NWAIT    *** Step 5
STROKE GUN#(1) LONG
```

When the manipulator reaches Step 5, the stroke is changed to Full open to avoid interference, and then the manipulator moves to the next step.

STRWAIT

SUBSET	STANDARD	EXPANDED	APPLICATIONS
Available	Available	Available	Spot

Function

Confirms the specified open status of a 2-step stroke gun as short open or full open when not welding.

Wait until the signal of the specified open status, short open or full open, is turned ON.

Construction

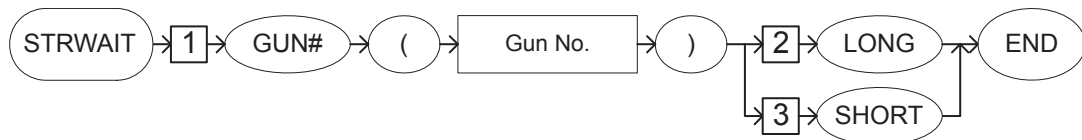

Explanation

1. GUN# (Gun number)

Add the following tag.

No	Tag	Explanation	Note
1	GUN# (Gun number)	Specify the number of the air gun whose open status is to be confirmed.	No.: 1 to 8 Variable B/I/D/LB/LI/LD can be used.

2. LONG/SHORT

Choose one of the tags from the following table.

No	Tag	Explanation	Note
2	LONG	Specify Full open.	
3	SHORT	Specify Short open.	

Example

```

MOVL V=1000 NWAIT    *** Step 5
STROKE GUN#(1) LONG
STRWAIT GUN#(1) LONG
  
```

When the manipulator reaches Step 5, the open status changes to Full open, and the manipulator confirms the Full open status before moving to the next step.

2.10 General-purpose Instruction

TOOLON

SUBSET	STANDARD	EXPANDED	APPLICATIONS
Available	Available	Available	General-purpose

Function

Turns ON the work instruction.

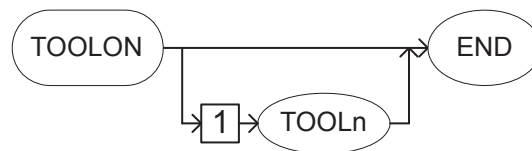
Construction**Explanation**

1. TOOLn

Choose one of the tags from the tool. These tags are valid for a system with multiple applications in which two or more general-purpose applications are included. These tags are not displayed when there is only one application.

No	Tag	Explanation	Note
1	TOOLn	Specifies the Tool.	n: 1 to 8 TOOL1: TOOL1

Example

(1) TOOLON

Turns ON the work instruction.

Turns ON the work start instruction (dedicated output relay #51530) and waits for the work start response (dedicated input relay #41130). When the work start response is turned ON, the next instruction is carried out.

The work start response relay is designed to turn ON immediately after the output of the work start instruction.

TOOLOF

SUBSET	STANDARD	EXPANDED	APPLICATIONS
Available	Available	Available	General-purpose

Function

Turns OFF the work instruction.

Construction

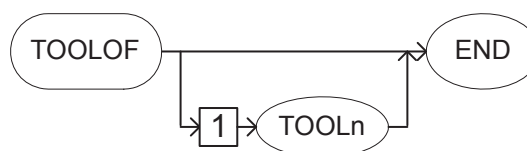

Explanation

1. TOOLn

Choose one of the tags from the tool. These tags are valid for a system with multiple applications in which two or more general-purpose applications are included. These tags are not displayed when there is only one application.

No	Tag	Explanation	Note
1	TOOLn	Specifies the Tool.	n: 1 to 8 TOOL1: TOOL1

Example

(1) TOOLOF

Turns OFF the work instruction.

Turns ON the work end instruction (dedicated output relay #51531) and waits for the work end response (dedicated input relay #41131). When the work end response is turned ON, the next instruction is carried out.

The work end response relay is designed to turn ON immediately after the output of the work end instruction.

DX100 OPTIONS INSTRUCTIONS

FOR INFORM LANGUAGE

HEAD OFFICE

2-1 Kurosakishiroishi, Yahatanishi-ku, Kitakyushu 806-0004 Japan
Phone +81-93-645-7745 Fax +81-93-645-7746

YASKAWA America Inc. MOTOMAN Robotics Division
100 Automation Way, Miamisburg, OH 45342, U.S.A.
Phone +1-937-847-6200 Fax +1-937-847-6277

YASKAWA Nordic AB
Verkstadsгатan 2, PO Box 504, SE-385 25 Torsås, Sweden
Phone +46-480-417-800 Fax +46-486-414-10

YASKAWA Europe GmbH Robotics Div.
Kammerfeldstr. 1, 80591 Allershausen, Germany
Phone +49-8166-90-0 Fax +49-8166-90-103

YASKAWA Electric Korea Co., Ltd
9F, KYOBO Securities Bldg., 26-4, Yeoido-Dong Yeoungpo-ku, Seoul, KOREA
Phone +82-2-784-7844 Fax +82-2-784-8495

YASKAWA Electric (Singapore) PTE Ltd.
151 Lorong Chuan, #04-02A, New Tech Park, Singapore 556741
Phone +65-6282-3003 Fax +65-6289-3003

YASKAWA Electric (Thailand) Co., Ltd.
252/246, 4th Floor, Muang Thai-Phatra Office Tower II Rachadaphisek Road, Huaykwang Bangkok, 10320 Thailand
Phone +66-2-693-2200 Fax +66-2-693-4200

YASKAWA Shougang Robot Co. Ltd.
No.7, Yongchang-North Road, Beijing E&T Development Area, China 100176
Phone +86-10-6788-0548 Fax +86-10-6788-0548-813

YASKAWA ELECTRIC (SHANGHAI) Co., Ltd.
No.18Xizang Zhong Road, 17F, Harbour Ring Plaza, Shanghai 200001, CHINA
Phone +86-21-5385-0655 Fax +86-21-5385-2770

YASKAWA Robotics India Ltd.
#426, Udyog Vihar, Phase- IV, Gurgaon, Haryana, India
Phone +91-124-475-8500 Fax +91-124-414-8016

Specifications are subject to change without notice
for ongoing product modifications and improvements.