

# SafeMove

## Protecting operators & enhancing robot safety



SafeMove, ABB's safety solution, provides greater flexibility, space savings, and cutting edge commissioning tools for higher productivity at a lower total cost of investment. All this, combined with unsurpassed safety, enables closer collaboration between robots and factory workers while reducing total investment by up to 30%.

ABB's SafeMove robotic safety solution can make ABB's other industrial robots also work collaboratively. SafeMove safeguards operators by replacing physical barriers like fences with virtual barriers such as laser scanners that ensure that a moving robot will never collide with a human because the robot will stop before the collision happens.

Robots are arguably one of the most important components of any flexible automation solution. They are capable of performing any number of applications from Arc Welding to Packaging. To be efficient robots must be able to move quickly making them a potential hazard for people working in their vicinity. Historically, fences or cages have been used to separate man from machine in an effort to keep them out of harm's way.

First introduced in 2008, SafeMove performs safety certified monitoring of robot motion, tool and standstill supervision as well as speed limitation.

Working hand-in-hand with our customers to develop innovative robot safety technologies, ABB introduces SafeMove. It allows for the creation of more efficient and flexible production scenarios, and integrates

safety fieldbus connectivity into ABB's IRC5 and OmniCore robot controller family.

### **Optimal balance between hardware and software**

SafeMove's functionality has evolved from hardware to software. This new generation of SafeMove encourages the development of innovative robot applications by integrating safety features directly into the robot controller. This evolution also has enabled the creation of features such as more zones, ranges and tools. Thanks to this added flexibility, additional features can be added over time.

SafeMove still includes miniaturized, dedicated hardware to ensure the performance of the safety system including a reliable safety IO. This dedicated hardware also ensures that the application running on the controller's main computer operates independently and is predictable.

### **Supported robots and controllers**

Able to support all robot mounting angles, SafeMove is available for use with the majority of ABB's robot portfolio as well as the IRC5 Single, Compact, Paint and OmniCore controllers.

### Collaboration

With SafeMove the tools to facilitate collaboration between man and machine are a reality. For example, if an operator needs to interact with the robot system, safety sensors can be incorporated into the robot cell to detect the person's presence. After detected, SafeMove with either supervise the robot's speed or monitor it while it is standing still. Once the person clears the zone, the robot can resume operation. The end result is less down time and increased productivity.

### RobotStudio®

Safety configurations are now faster and more efficient. Taking full advantage of our premier offline programming tool, RobotStudio, programmers can intuitively & easily visualize safety zones with the assistance of simulations & 3D graphics.

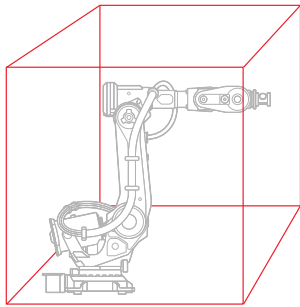

### Faster commissioning times

SafeMove includes a set of easy-to-use tools for fast setup, validation and commissioning. One such tool, SafeMove Visualizer, puts SafeMove configurations directly onto the ABB FlexPendant. The GUI can display detailed safety zones for fast and precise analysis of a zone or axis violation. It also incorporates effective commissioning workflow by offering complete control over every safety functions.

### Features and benefits

- Enables lean, flexible, & economic robot solutions
- Designed to keep humans and equipment completely safe
- Saves floor space
- Facilitates human/robot collaboration
- Enables hazardous applications such as X-ray inspections and laser cutting

Features	
Safety fieldbuses	Built-in safety fieldbuses eliminating the need for dedicated hardware for communication with safety equipment such as safety PLC's & light curtains.
Tool position supervision	Protects the operator and enhances machine and equipment safety by supervising the position of the tool.
Tool speed supervision	Protects the operator and enhances machine and equipment safety by supervising the speed of the tool.
Tool orientation supervision	Protects the operator and enhances machine and equipment safety by supervising the orientation of the tool.
Axis position supervision	Protects the surroundings and operators by supervising the axis position.
Axis speed supervision	Protects the surroundings and operators by supervising the axis speed.
Functions	
Standstill supervision	Supervises the stand-still of robot axes without having to switch the robot to Motors Off. It enables operators to perform tasks in the immediate vicinity of the robot.
Contact application tolerance	Allows the robot to be in contact with work-piece in limited areas. This can for example be used in applications where the robot is used for grinding or during tool change.
Cyclic brake check	Cyclic brake check Supervises that the brakes are checked with a cyclic interval.
Stop functions	Triggers stop of the robot using fieldbus inputs from the safety PLC.
Configuration	Performed in RobotStudio using Visual SafeMove configurator.