

ROBOTICS

Product specification

IRB 120



Trace back information:

Workspace OmniCore and R19C version a16

Checked in 2019-09-16

Skribenta version 5.3.012

Product specification

IRB 120

IRC5

Document ID: 3HAC035960-001

Revision: T

The information in this manual is subject to change without notice and should not be construed as a commitment by ABB. ABB assumes no responsibility for any errors that may appear in this manual.

Except as may be expressly stated anywhere in this manual, nothing herein shall be construed as any kind of guarantee or warranty by ABB for losses, damages to persons or property, fitness for a specific purpose or the like.

In no event shall ABB be liable for incidental or consequential damages arising from use of this manual and products described herein.

This manual and parts thereof must not be reproduced or copied without ABB's written permission.

Keep for future reference.

Additional copies of this manual may be obtained from ABB.

Original instructions.

© Copyright 2010-2019 ABB. All rights reserved.
Specifications subject to change without notice.

Table of contents

Overview of this specification	7
1 Description	9
1.1 Structure	9
1.1.1 Introduction to structure	9
1.1.2 The robot	11
1.2 Standards	13
1.2.1 Applicable standards	13
1.3 Installation	15
1.3.1 Operating requirements	16
1.3.2 Mounting the manipulator	17
1.4 Load diagram	20
1.4.1 Introduction to load diagrams	20
1.4.2 Load diagrams	21
1.4.3 Maximum load and moment of inertia for full and limited axis 5 (center line down) movement	23
1.5 Mounting of equipment	25
1.5.1 Holes for mounting extra equipment	26
1.6 Calibration	28
1.6.1 Calibration methods	28
1.6.2 Fine calibration	29
1.6.3 Absolute Accuracy option	30
1.7 Maintenance and trouble shooting	32
1.7.1 Introduction to maintenance and trouble shooting	32
1.8 Robot motion	33
1.8.1 Working range and type of motion	33
1.8.2 Performance according to ISO 9283	35
1.8.3 Velocity	36
1.8.4 Robot stopping distances and times	37
1.9 Customer connections	38
1.9.1 Introduction to customer connections	38
2 Specification of variants and options	39
2.1 Introduction to variants and options	39
2.2 Manipulator	40
2.3 Floor cables	42
2.4 Process	43
2.5 User documentation	44
3 Accessories	45
3.1 Introduction to accessories	45
Index	47

This page is intentionally left blank

Overview of this specification

About this product specification

It describes the performance of the manipulator or a complete family of manipulators in terms of:

- The structure and dimensional prints
- The fulfilment of standards, safety and operating requirements
- The load diagrams, mounting of extra equipment, the motion and the robot reach
- The specification of variants and options available

Usage

Product specifications are used to find data and performance about the product, for example to decide which product to buy. How to handle the product is described in the product manual.

Users

It is intended for:

- Product managers and product personnel
- Sales and marketing personnel
- Order and customer service personnel

References

Reference	Document ID
<i>Product specification - Controller IRC5</i> IRC5 with main computer DSQC1000.	3HAC047400-001
<i>Product specification - Controller software IRC5</i> IRC5 with main computer DSQC1000 and RobotWare 5.6x.	3HAC050945-001
<i>Product specification - Controller software IRC5</i> IRC5 with main computer DSQC1000 and RobotWare 6.	3HAC050945-001
<i>Product specification - Robot stopping distances according to ISO 10218-1</i>	3HAC048645-001
<i>Product manual - IRB 120</i>	3HAC035728-001
<i>Operating manual - IRC5 with FlexPendant</i>	3HAC050941-001
<i>Product specification - Robot user documentation, IRC5 with RobotWare 6</i>	3HAC052355-001

Revisions

Revision	Description
-	New product specification
A	Options 431-1 and 239-1 added
B	Standards updated, minor corrections
C	Size of washer for mounting the manipulator adjusted

Continues on next page

Overview of this specification

Continued

Revision	Description
D	Table for ambient temperature is adjusted
E	<ul style="list-style-type: none"> • <i>Clean Room</i> option added • Machinery directive updated
F	<ul style="list-style-type: none"> • New robot variant added • General corrections
G	<ul style="list-style-type: none"> • Added data for extended range of movement of axis 6. • Changed the illustration that shows the mounting surface of the tool flange.
H	<ul style="list-style-type: none"> • Minor corrections and updates
J	<ul style="list-style-type: none"> • Minor corrections and updates
K	<ul style="list-style-type: none"> • Text for ISO test adjusted • Robot stopping distances and times for category 0 and category 1 stops are moved to a separate document, <i>Product specification - Robot stopping distances according to ISO 10218-1</i>.
L	<ul style="list-style-type: none"> • The list of applicable safety standards is updated. The IRB 120 does not comply with the CSA/UL standards, see Applicable standards on page 13. • Minor corrections/update
M	<ul style="list-style-type: none"> • Minor corrections/update
N	<ul style="list-style-type: none"> • Clean Room option added • Food grade lubrication option added • Axis Calibration method added
P	Published in release R17.1. The following updates are done in this revision: <ul style="list-style-type: none"> • Minor corrections/update • Restriction of Load diagram added • Add options of Connection of parallel communication
Q	Published in release R17.2. The following updates are done in this revision: <ul style="list-style-type: none"> • Change the drawing of Load diagrams. • Updated list of applicable standards.
R	Published in release R18.2. The following updates are done in this revision: <ul style="list-style-type: none"> • Update customer connector description.
S	Published in release R19B The following updates are done in this revision: <ul style="list-style-type: none"> • 435-109 IRB 120T-3/0.6 phased out. • Updated information about <i>Absolute Accuracy</i>.
T	Published in release R19C The following updates are done in this revision: <ul style="list-style-type: none"> • Minor change in Ambient temperature section. • Note added about need to calibrate if the robot is other than floor mounted.

1 Description

1.1 Structure

1.1.1 Introduction to structure

General

The IRB 120 is one of ABB Robotics latest generation of 6-axis industrial robot, with a payload of 3 kg, designed specifically for manufacturing industries that use flexible robot-based automation, e.g. 3C industry.

The robot has an open structure that is especially adapted for flexible use, and can communicate extensively with external systems.

Clean room robots



xx1100000959

Particle emission from the robot fulfill Clean room class 5 standard according to DIN EN ISO 14644-1.

Clean room robots are specially designed to work in a clean room environment. According to IPA test result, the robot IRB 120 is suitable for use in Clean Room environment.

Clean room robots are designed in order to prevent from particle emission from the robot. For example is, frequent maintenance work possible to perform without cracking the paint. The robot is painted with four layers of polyurethane paint. The last layer being a varnish over labels in order to simplify cleaning. The paint has been tested regarding outgassing of Volatile Organic Compounds (VOC) and been classified in accordance with ISO 14644-8.

Classification of airborne molecular contamination, see below:

Parameter				Outgassing amount		
Area (m ²)	Test duration (s)	Temp (°C)	Performed test	Total detected (ng)	Normed based on 1m ² and 1s(g)	Classification in accordance to ISO 14644-8
4.5E-03	3600	23	TVOC	2848	1.7E-07	-6.8
4.5E-03	60	90	TVOC	46524	1.7E-04	-3.8

Classification results in accordance with ISO 14644-8 at different test temperatures.

Food grade lubrication

The robot has food grade lubrication (NSF H1) as an option. The protection type for robots with food grade lubrication is Clean Room.

Continues on next page

1 Description

1.1.1 Introduction to structure

Continued

Operating system

The robot is equipped with the IRC5 Compact or IRC5 (Single cabinet) controller and robot control software, RobotWare. RobotWare supports every aspect of the robot system, such as motion control, development and execution of application programs, communication etc. See *Product specification - Controller IRC5 with FlexPendant* and *Product specification - Controller software IRC5*.

Safety

Safety standards valid for complete robot, manipulator and controller.

Additional functionality

For additional functionality, the robot can be equipped with optional software for application support - for example gluing and welding, communication features - network communication - and advanced functions such as multitasking, sensor control etc. For a complete description on optional software, see *Product specification - Controller software IRC5*.

Manipulator axes

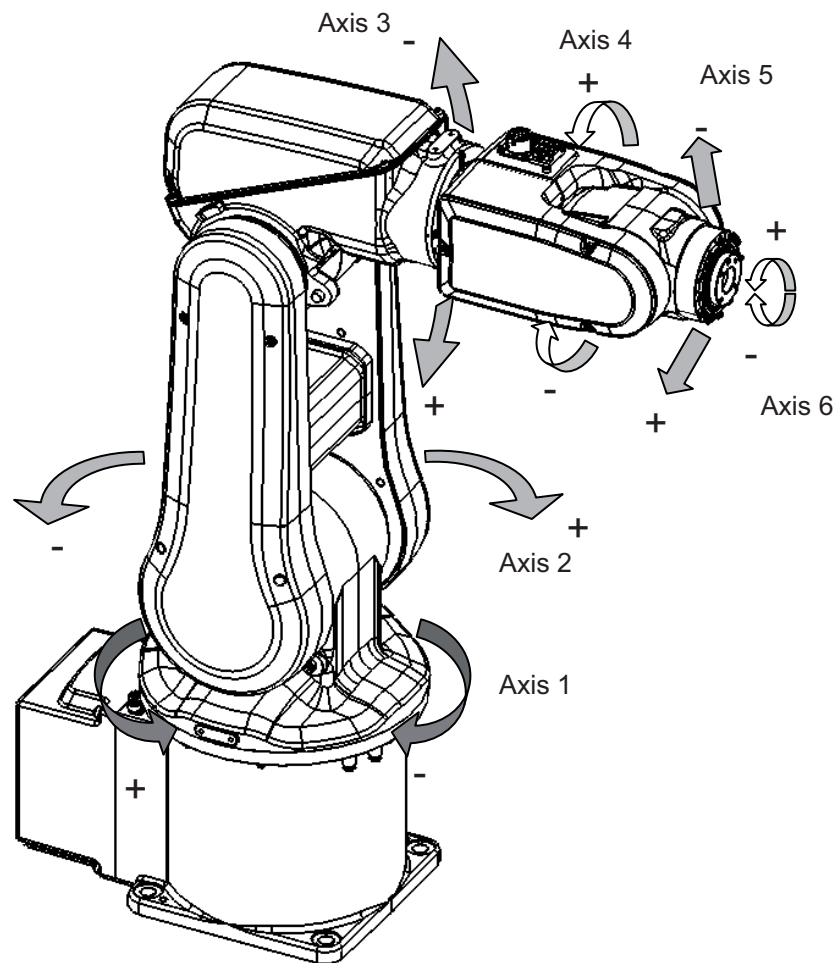

xx0900000262

1.1.2 The robot

General

The IRB 120-3/0.6 is available in two versions and both can be mounted on floor, inverted or on wall in any angle (tilted around X or Y axis).

Robot type	Handling capacity (kg)	Reach (m)
IRB 120	3 kg	0.58 m

Manipulator weight

Data	Weight
IRB 120-3/0.6	25 kg

Other technical data

Data	Description	Note
Airborne noise level	The sound pressure level outside	< 70 dB (A) Leq (acc. to the working space Machinery directive 2006/42/EG)

Power consumption

Path E1-E2-E3-E4 in the ISO Cube, maximum load.

Type of movement	Power consumption (kW)
ISO Cube Max. velocity	0.24 kW
Robot in 0 degree position	IRB 120
Brakes engaged	0.095 kW
Brakes disengaged	0.173 kW

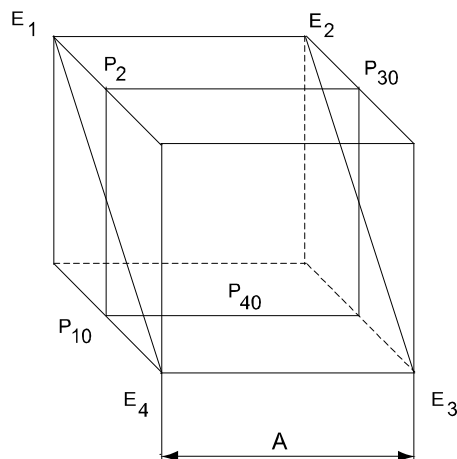

xx0900000265

Position	Description
A	250 mm

Continues on next page

1 Description

1.1.2 The robot

Continued

Dimensions IRB 120-3/0.6

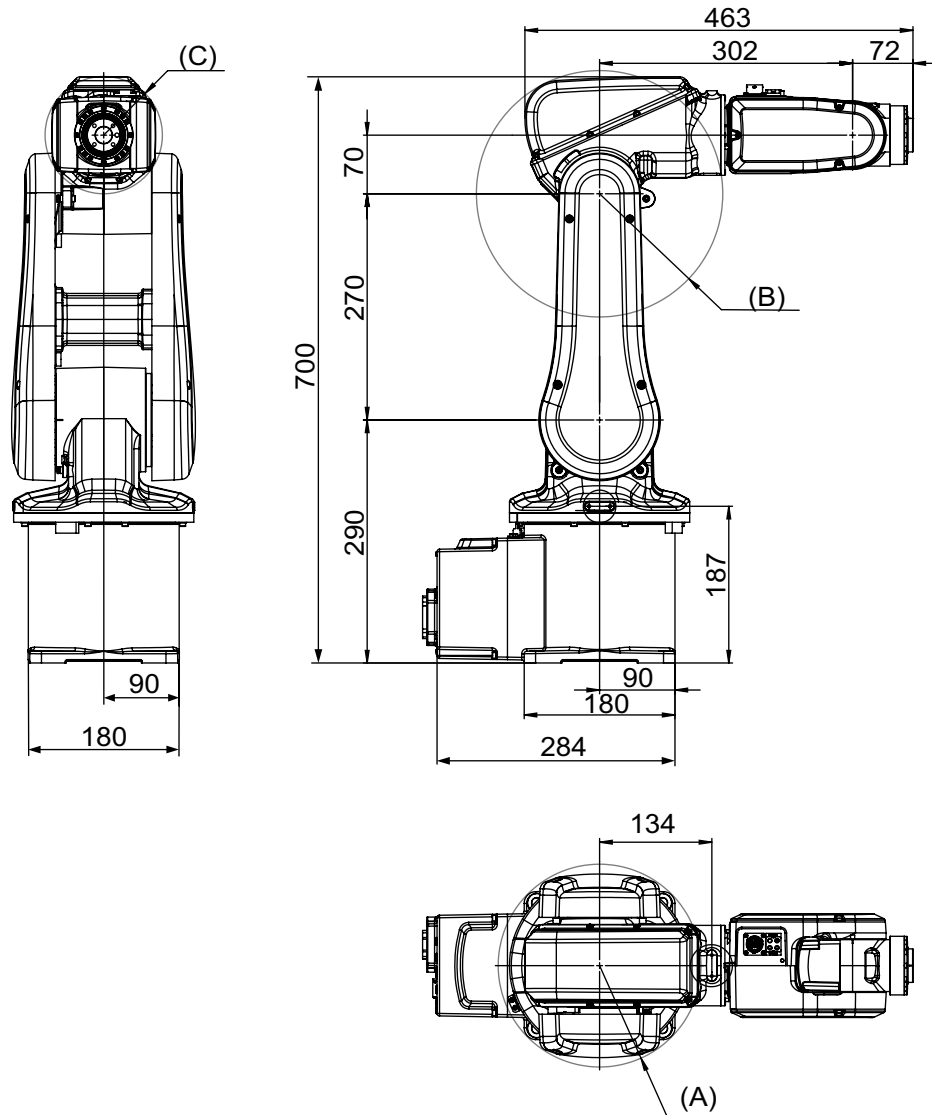

xx0900000256

Position	Description
A	Minimum turning radius axis 1 R=121 mm
B	Minimum turning radius axis 3 R=147 mm
C	Minimum turning radius axis 4 R=70 mm

1.2 Standards

1.2.1 Applicable standards



Note

The listed standards are valid at the time of the release of this document. Phased out or replaced standards are removed from the list when needed.

Standards, EN ISO

The product is designed in accordance with the requirements of:

Standard	Description
EN ISO 12100:2010	Safety of machinery - General principles for design - Risk assessment and risk reduction
EN ISO 13849-1:2015	Safety of machinery, safety related parts of control systems - Part 1: General principles for design
EN ISO 13850:2015	Safety of machinery - Emergency stop - Principles for design
EN ISO 10218-1:2011	Robots for industrial environments - Safety requirements -Part 1 Robot
ISO 9787:2013	Robots and robotic devices -- Coordinate systems and motion nomenclatures
ISO 9283:1998	Manipulating industrial robots, performance criteria, and related test methods
EN ISO 14644-1:2015 ⁱ	Classification of air cleanliness
EN ISO 13732-1:2008	Ergonomics of the thermal environment - Part 1
EN 61000-6-4:2007 + A1:2011 IEC 61000-6-4:2006 + A1:2010 (option 129-1)	EMC, Generic emission
EN 61000-6-2:2005 IEC 61000-6-2:2005	EMC, Generic immunity
EN IEC 60974-1:2012 ⁱⁱ	Arc welding equipment - Part 1: Welding power sources
EN IEC 60974-10:2014 ⁱⁱ	Arc welding equipment - Part 10: EMC requirements
EN IEC 60204-1:2006	Safety of machinery - Electrical equipment of machines - Part 1 General requirements
IEC 60529:1989 + A2:2013	Degrees of protection provided by enclosures (IP code)

ⁱ Only robots with protection Clean Room.

ⁱⁱ Only valid for arc welding robots. Replaces EN IEC 61000-6-4 for arc welding robots.

European standards

Standard	Description
EN 614-1:2006 + A1:2009	Safety of machinery - Ergonomic design principles - Part 1: Terminology and general principles

Continues on next page

1 Description

1.2.1 Applicable standards

Continued

Standard	Description
EN 574:1996 + A1:2008	Safety of machinery - Two-hand control devices - Functional aspects - Principles for design

1.3 Installation

General

IRB 120 is adapted for normal industrial environment. An end effector, weighing a maximum of 3 kg, including payload, can be mounted on the robot's mounting flange (axis 6). Other equipment, weighing a maximum of 0.3 kg, can be mounted on the upper arm. For more information about mounting of extra equipment, see Figure on next page.

Continues on next page

1 Description

1.3.1 Operating requirements

1.3.1 Operating requirements

Protection standard

Protection standard	IEC529
All variants, manipulator	IP30

Explosive environments

The robot must not be located or operated in an explosive environment.

Working range limitations

It is not possible to select EPS together with IRC5 Compact. No mechanical limitation.

Ambient temperature

Description	Protection class	Temperature
Manipulator during operation	Standard	+ 5 °C ⁱ (41 °F) to + 45 °C (113 °F)
Manipulator with food grade lubrication during operation	Option	+ 5 °C ⁱ (41 °F) to + 35 °C ⁱⁱ (95 °F)
For the controller	Standard/Option	<i>Product specification - Controller IRC5 with FlexPendant</i>
Complete robot during transportation and storage	Standard	- 25 °C (-13 °F) to + 55 °C (131 °F)
For short periods (not exceeding 24 hours)	Standard	up to + 70 °C (158 °F)

- ⁱ At low environmental temperature < 10°C is, as with any other machine, a warm-up phase recommended to be run with the robot. Otherwise there is a risk that the robot stops or run with lower performance due to temperature dependent oil and grease viscosity.
- ⁱⁱ For robots with food grade lubrication, if environment temperature > 35°C, contact ABB for further information.

Relative humidity

Description	Relative humidity
Complete robot during operation, transportation and storage	Max. 95% at constant temperature

1.3.2 Mounting the manipulator

Maximum load

Maximum load in relation to the base coordination system. See Figure below.

Floor Mounted

Force	Endurance load (in operation)	Max. load (emergency stop)
Force xy	±265 N	±515 N
Force z	-265 ±200 N	-265 ±365 N
Torque xy	±195 Nm	±400 Nm
Torque z	±85 Nm	±155 Nm

Wall Mounted

Force	Endurance load (in operation)	Max. load (emergency stop)
Force xy	±470 N	±735 N
Force z	0 ±200 N	0 ±630 N
Torque xy	±240 Nm	±450 Nm
Torque z	±90 Nm	±175 Nm

Suspended

Force	Endurance load (in operation)	Max. load (emergency stop)
Force xy	±265 N	±515 N
Force z	265 ±200 N	265 ±365 N
Torque xy	±195 Nm	±400 Nm
Torque z	±85 Nm	±155 Nm

Continues on next page

1 Description

1.3.2 Mounting the manipulator

Continued

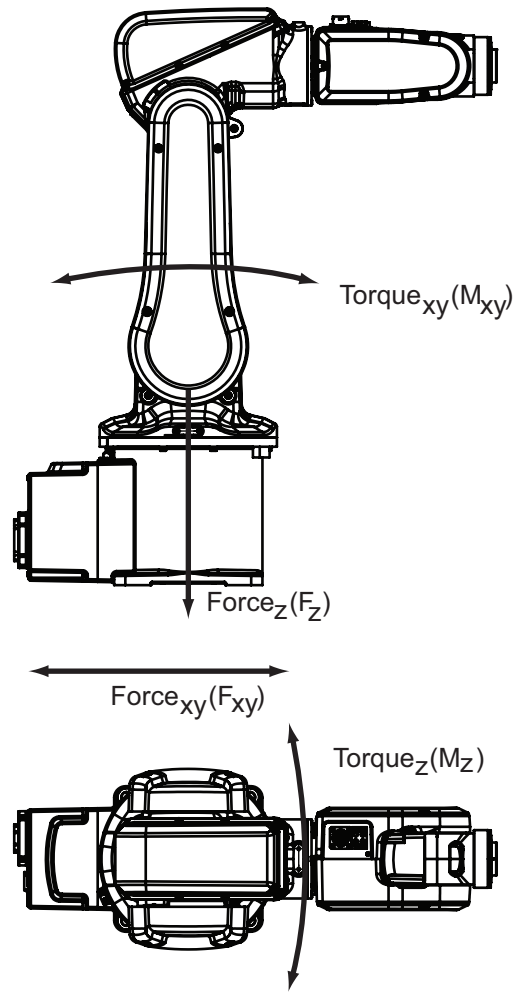

xx0900000257

Note regarding M_{xy} and F_{xy}

The bending torque (M_{xy}) can occur in any direction in the XY-plane of the base coordinate system. The same applies to the transverse force (F_{xy}).

Continues on next page

Fastening holes robot base

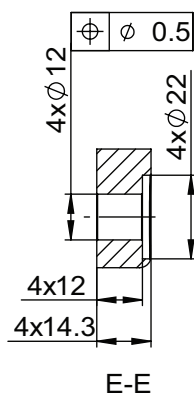
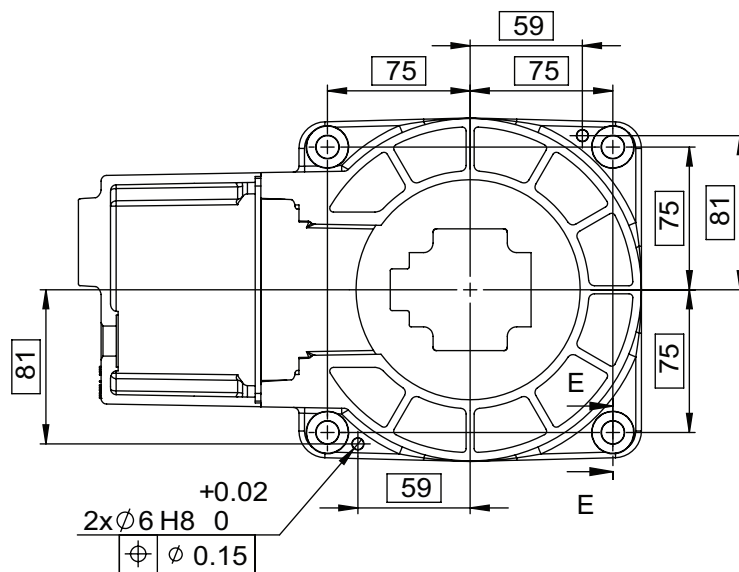

xx0900000258

Attachment bolts, specification

The table below specifies required bolts and washers for securing the robot at installation site.

Specification	Description
Attachment bolts, 4 pcs	M10 x 25 (installation directly on foundation)
Guide pins, 2 pcs	D=6x20
Washers, 4 pcs	10.5 x 20 x 2
Quality	Quality 8.8
Tightening torque	47 Nm

1 Description

1.4.1 Introduction to load diagrams

1.4 Load diagram

1.4.1 Introduction to load diagrams

Information



WARNING

It is very important to always define correct actual load data and correct payload of the robot. Incorrect definitions of load data can result in overloading of the robot.

If incorrect load data and/or loads are outside load diagram is used the following parts can be damaged due to overload:

- motors
- gearboxes
- mechanical structure



WARNING

In the robot system there is a service routine called *LoadIdentify* available, which allows the user to make an automatic definition of the tool and load, to determine correct load parameters. See *Operating manual - IRC5 with FlexPendant*.



WARNING

Robots running with incorrect load data and/or with loads outside diagram, will not be covered by robot warranty.

General

The load diagram includes a nominal pay load inertia, J_0 of 0.012 kgm^2 and an extra load of 0.3 kg at the upper arm housing. At different moment of inertia the load diagram will be changed. For robots that are allowed tilted, wall or inverted mounted, the load diagrams as given are valid and thus it is also possible to use RobotLoad within those tilt and axis limits.

Control of load case with RobotLoad

To easily control a specific load case, use the calculation program ABB RobotLoad. Contact your local ABB organization for more information.

The result from RobotLoad is only valid within the maximum loads and tilt angles. There is no warning if the maximum permitted armload is exceeded. For over load cases and special applications, contact ABB for further analysis.

1.4.2 Load diagrams

IRB 120 - 3/0.6

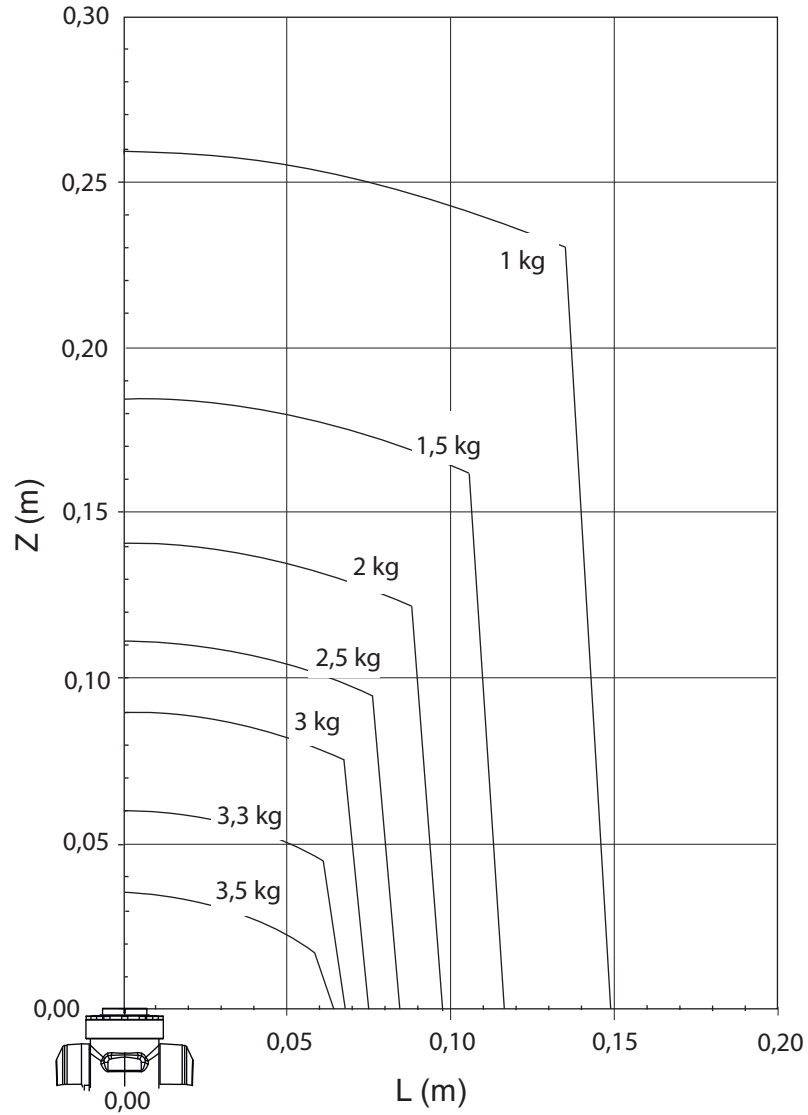

xx0900000370

Continues on next page

1 Description

1.4.2 Load diagrams

Continued

IRB 120 - 3/0.6 "Vertical wrist" ($\pm 10^\circ$)

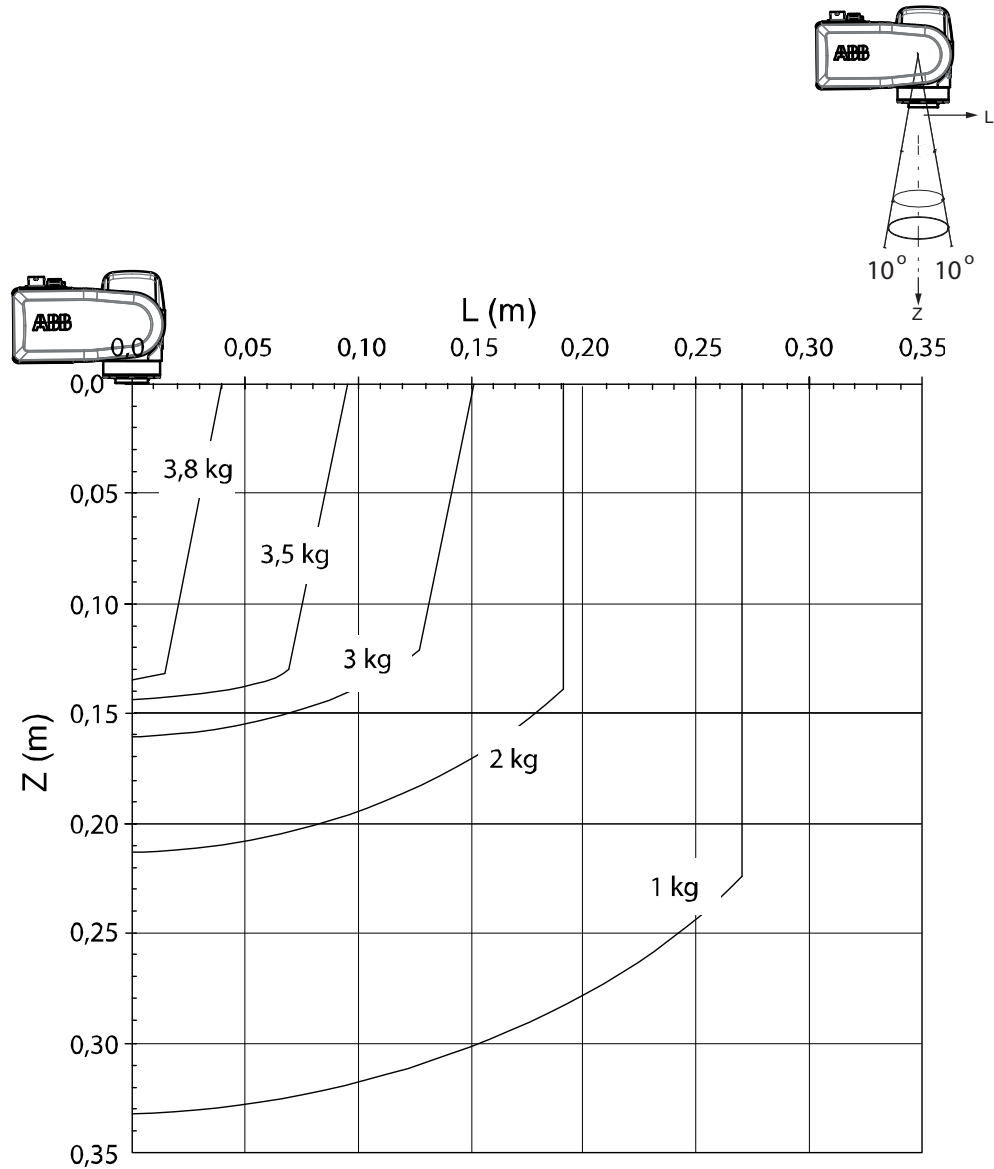

xx0900000371

	Description
Max load	4.2 kg
Z _{max}	0.119 m
L _{max}	0.022 m

1.4.3 Maximum load and moment of inertia for full and limited axis 5 (center line down) movement

1.4.3 Maximum load and moment of inertia for full and limited axis 5 (center line down) movement

General

Total load given as: Mass in kg, center of gravity (Z and L) in m and moment of inertia (J_{ox} , J_{oy} , J_{oz}) in kgm^2 . $L = \sqrt{(x_2 + y_2)}$, see Figure 8.

Full movement of axis 5 ($\pm 115^\circ$)

Axis	Robot Type	Max. value
5	IRB 120(T)-3/0.6	$J_5 = \text{Mass} \times ((Z + 0.072)^2 + L^2) + \max(J_{ox}, J_{oy}) \leq 0.175 \text{ kgm}^2$
6	IRB 120(T)-3/0.6	$J_6 = \text{Mass} \times L^2 + J_{oz} \leq 0.085 \text{ kgm}^2$

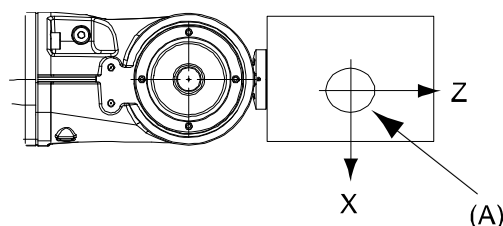

xx0800000458

Pos	Description
A	Center of gravity
	Description
J_{ox}, J_{oy}, J_{oz}	Max. moment of inertia around the X, Y and Z axes at center of gravity.

Limited axis 5, center line down

Axis	Robot Type	Max. value
5	IRB 120(T)-3/0.6	$J_5 = \text{Mass} \times ((Z + 0.072)^2 + L^2) + \max(J_{ox}, J_{oy}) \leq 0.175 \text{ kgm}^2$
6	IRB 120(T)-3/0.6	$J_6 = \text{Mass} \times L^2 + J_{oz} \leq 0.085 \text{ kgm}^2$

Continues on next page

1 Description

1.4.3 Maximum load and moment of inertia for full and limited axis 5 (center line down) movement

Continued

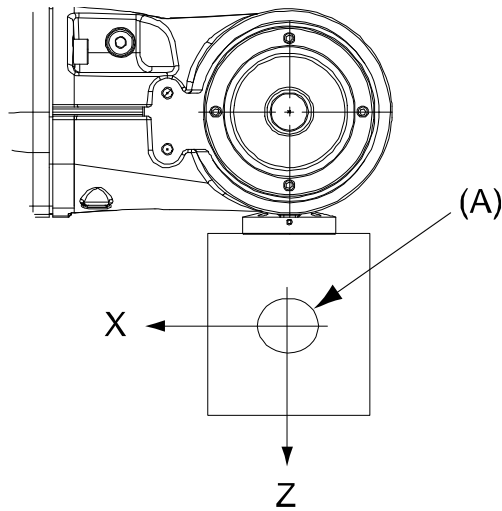

xx0800000459

Position	Description
A	Center of gravity
	Description
J_{ox}, J_{oy}, J_{oz}	Max. moment of inertia around the X, Y and Z axes at center of gravity.

Wrist torque

The table below shows the maximum permissible torque due to payload.



Note

The values are for reference only, and should not be used for calculating permitted load offset (position of center of gravity) within the load diagram, since those also are limited by main axes torques as well as dynamic loads. Also arm loads will influence the permitted load diagram, please contact your local ABB organization.

Robot type	Max wrist torque axis 4 and 5	Max wrist torque axis 6	Max torque valid at load
IRB 120(T)-3/0.6	4.8 Nm	2.2 Nm	3 kg

1.5 Mounting of equipment

General

Extra loads can be mounted on to the upper arm and frame. Definitions of load areas and permitted load are shown in Figure 10. The center of gravity of the extra load shall be within the marked load areas. The robot is supplied with holes for mounting of extra equipment. (See figures in [Holes for mounting extra equipment on page 26.](#))

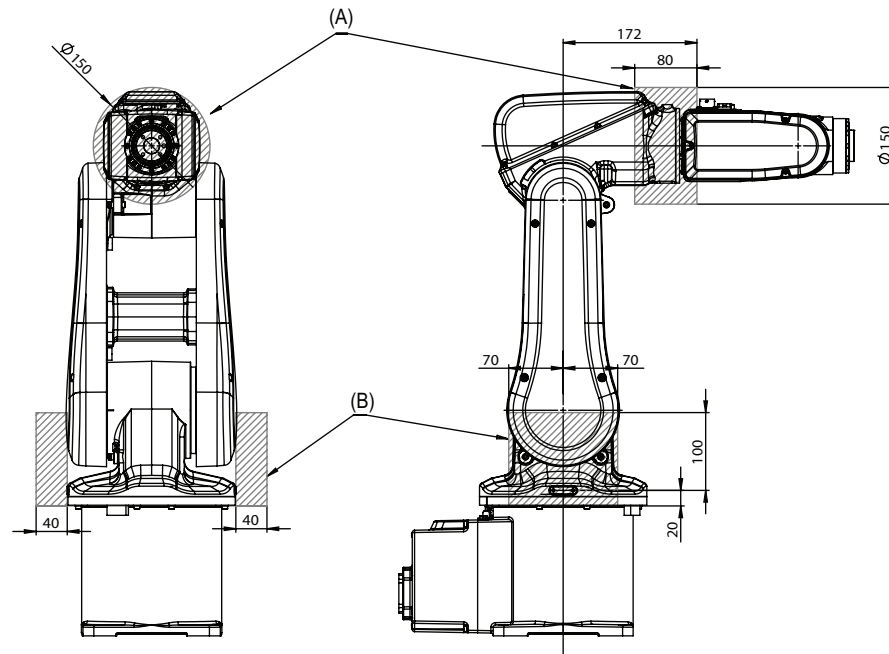

xx0900000369

Load area	Max load	
	A	B
IRB 120-3/0.6	0.3 kg	0.5 (x2) kg

Continues on next page

1 Description

1.5.1 Holes for mounting extra equipment

1.5.1 Holes for mounting extra equipment

Upper arm

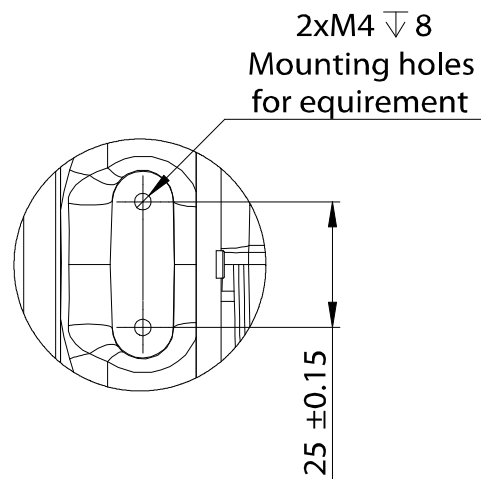
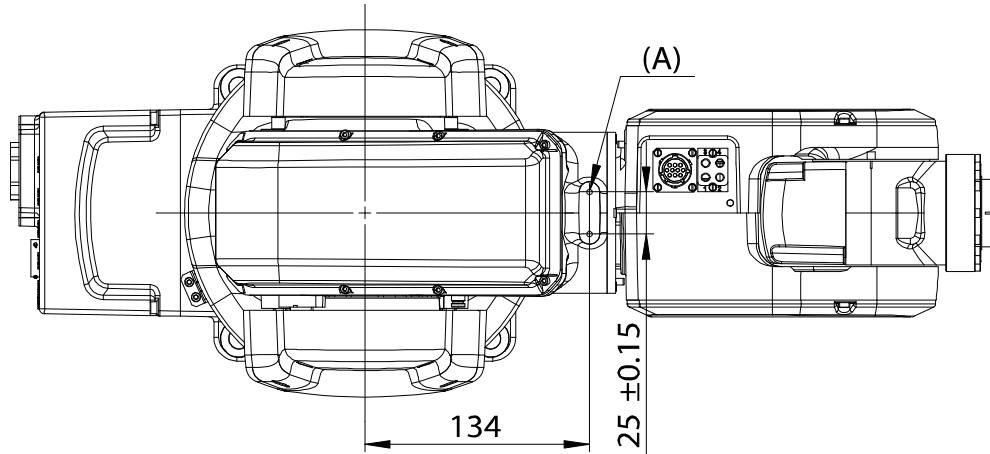

xx0900000259

Continues on next page

1 Description

1.6.1 Calibration methods

1.6 Calibration

1.6.1 Calibration methods

Overview

This section specifies the different types of calibration and the calibration methods that are supplied by ABB.

The original calibration data delivered with the robot is generated when the robot is floor mounted. If the robot is not floor mounted, then the robot accuracy could be affected. The robot needs to be calibrated after it is mounted.

More information is available in the product manual.

Types of calibration

Type of calibration	Description	Calibration method
Standard calibration	The calibrated robot is positioned at calibration position. Standard calibration data is found on the SMB (serial measurement board) or EIB in the robot. For robots with RobotWare 5.04 or older, the calibration data is delivered in a file, calib.cfg, supplied with the robot at delivery. The file identifies the correct resolver/motor position corresponding to the robot home position.	Axis Calibration or manual calibration ⁱ

ⁱ The robot is calibrated by either manual calibration or Axis Calibration at factory. Always use the same calibration method as used at the factory.
Information about valid calibration method is found on the calibration label or in the calibration menu on the FlexPendant.
If no data is found related to standard calibration, manual calibration is used as default.

Brief description of calibration methods

Axis Calibration method

Axis Calibration is a standard calibration method for calibration of IRB 120 and is the most accurate method for the standard calibration. It is the recommended method in order to achieve proper performance.

The following routines are available for the Axis Calibration method:

- Fine calibration
- Update revolution counters

The calibration equipment for Axis Calibration is delivered as a toolkit.

The actual instructions of how to perform the calibration procedure and what to do at each step is given on the FlexPendant. You will be guided through the calibration procedure, step by step.

1.6.2 Fine calibration

General

Fine calibration is made using the Axis Calibration method (from RobotWare 6.03.01). For detailed information on calibration of the robot see *Product manual - IRB 120*.

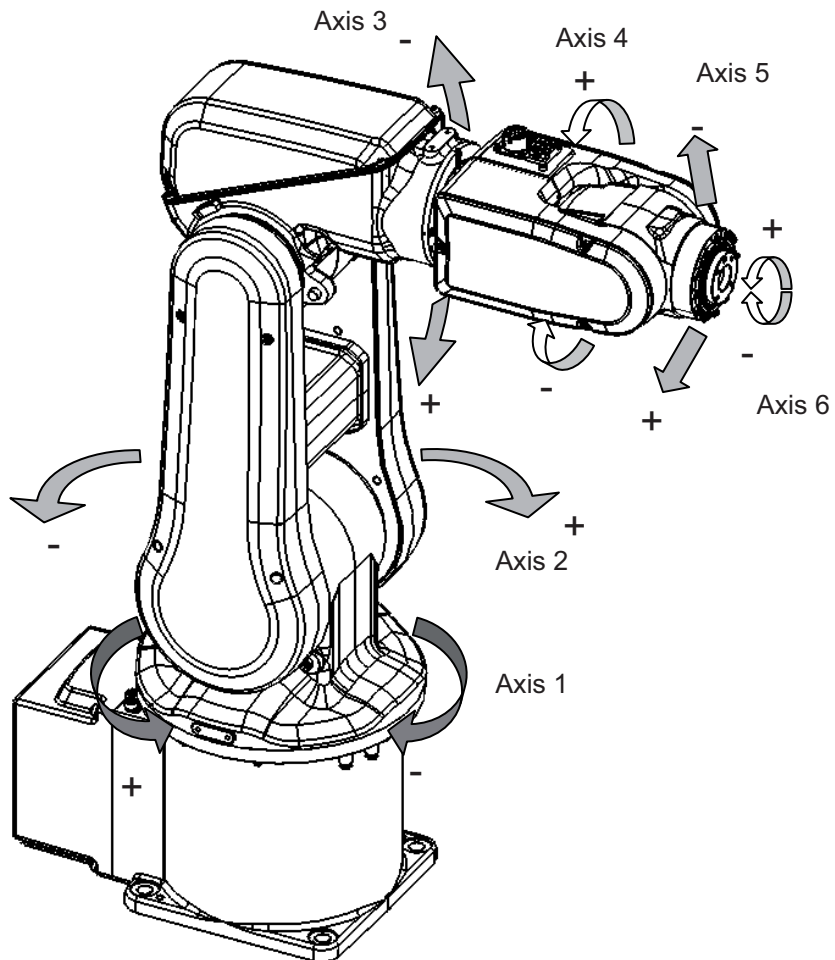

xx090000262

Calibration	Position
Calibration of all axes	All axes in zero position
Calibration of axis 1 and 2	Axis 1 and 2 in zero position Axis 3 to 6 in any position
Calibration of axis 1	Axis 1 in zero position Axis 2 to 6 in any position

1 Description

1.6.3 Absolute Accuracy option

1.6.3 Absolute Accuracy option

Purpose

Absolute Accuracy is a calibration concept that improves TCP accuracy. The difference between an ideal robot and a real robot can be several millimeters, resulting from mechanical tolerances and deflection in the robot structure. Absolute Accuracy compensates for these differences.

Here are some examples of when this accuracy is important:

- Exchangeability of robots
- Offline programming with non or minimum touch-up
- Online programming with accurate movement and reorientation of tool
- Accurate cell alignment for MultiMove coordinated motion
- Programming with accurate offset movement in relation to eg. vision system or offset programming
- Re-use of programs between applications

The option Absolute Accuracy is integrated in the controller algorithms and does not need external equipment or calculation.



Note

The performance data is applicable to the corresponding RobotWare version of the individual robot.

What is included

Every Absolute Accuracy robot is delivered with:

- compensation parameters saved on the robot's serial measurement board
- a birth certificate representing the Absolute Accuracy measurement protocol for the calibration and verification sequence.

A robot with Absolute Accuracy calibration is marked on the manipulator.

Absolute Accuracy supports both floor mounted and inverted installations. The compensation parameters differ depending on if the robot is floor mounted or inverted.

When is Absolute Accuracy being used

Absolute Accuracy works on a robot target in Cartesian coordinates, not on the individual joints. Therefore, joint based movements (e.g. *MoveAbsJ*) will not be affected.

If the robot is inverted, the Absolute Accuracy calibration must be performed when the robot is inverted.

Absolute Accuracy active

Absolute Accuracy will be active in the following cases:

- Any motion function based on robtargets (e.g. *MoveL*) and ModPos on robtargets
- Reorientation jogging

Continues on next page

- Linear jogging
- Tool definition (4, 5, 6 point tool definition, room fixed TCP, stationary tool)
- Work object definition

Absolute Accuracy not active

The following are examples of when Absolute Accuracy is not active:

- Any motion function based on a jointtarget (`MoveAbsJ`)
- Independent joint
- Joint based jogging
- Additional axes
- Track motion



Note

In a robot system with, for example, an additional axis or track motion, the Absolute Accuracy is active for the manipulator but not for the additional axis or track motion.

RAPID instructions

There are no RAPID instructions included in this option.

MultiMove

If the main robot in a MultiMove system has the Absolute Accuracy option, it opens up Absolute Accuracy capability for all the robots in the system. However, each robot needs to be calibrated individually.



Note

Note that this is the only RobotWare option that is relevant for an additional robot.



Note

It is possible to mix robots with and without the option Absolute Accuracy arbitrarily in a MultiMove system.

1 Description

1.7.1 Introduction to maintenance and trouble shooting

1.7 Maintenance and trouble shooting

1.7.1 Introduction to maintenance and trouble shooting

General

The robot requires only a minimum of maintenance during operation. It has been designed to make it as easy to service as possible:

- Maintenance-free AC motors are used.
- Grease used for all gearboxes.
- The cabling is routed for longevity, and in the unlikely event of a failure, its modular design makes it easy to change.

Maintenance

The maintenance intervals depend on the use of the robot, the required maintenance activities also depends on selected options. For detailed information on maintenance procedures, see *Maintenance* section in the *Product Manual - IRB 120*.

1.8 Robot motion

1.8.1 Working range and type of motion

Working range

The figures show the working ranges of the robot.

The extreme positions of the robot arm are specified at the wrist center (dimensions in mm).

Working range

The illustration shows the unrestricted working range of the robot.

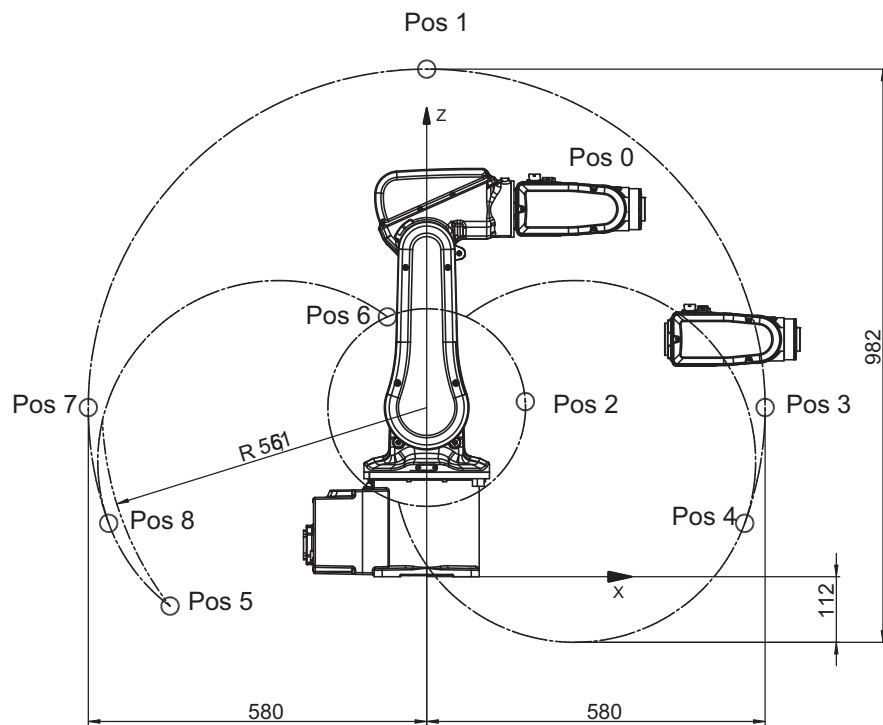

xx0900000263

Position	Position at wrist center (mm)		Angle (degrees)	
	X	Z	Axis 2	Axis 3
A	302 mm	630 mm	0°	0°
B	0 mm	870 mm	0°	-77°
C	169 mm	300 mm	0°	+70°
D	580 mm	270 mm	+90°	-77°
E	545 mm	91 mm	+110°	-77°
F	-440 mm	-50 mm	-110°	-110°
G	-67 mm	445 mm	-110°	+70°
H	-580 mm	270 mm	-90°	-77°
J	-545 mm	91 mm	-110°	-77°

Continues on next page

1 Description

1.8.1 Working range and type of motion

Continued

Turning radius

The turning radius of robot is shown in the figure.

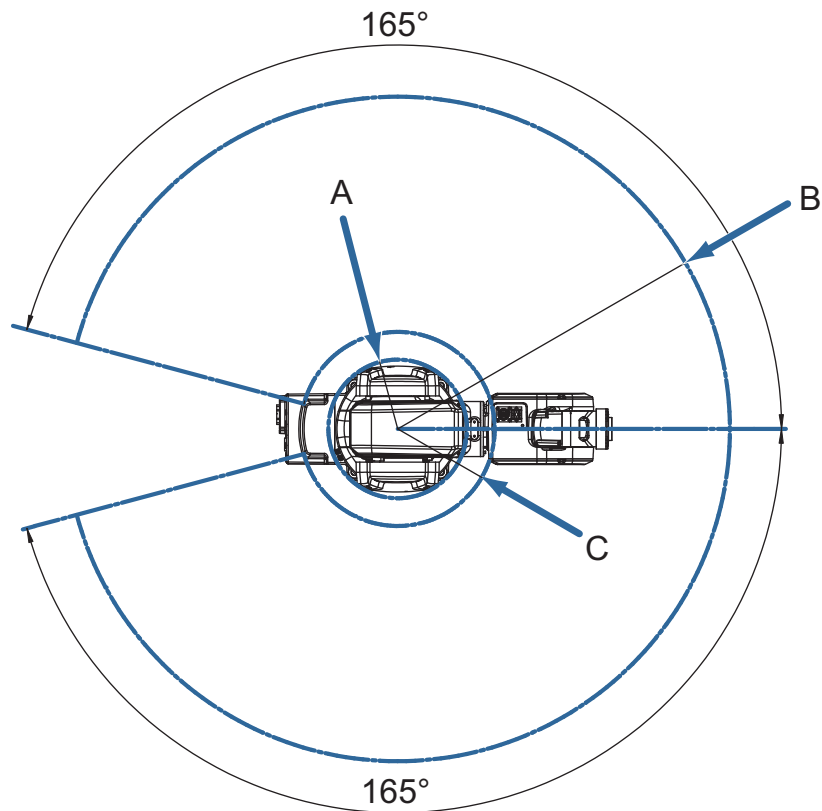

xx0900000157

Robot variant	Pos. A	Pos. B	Pos. C
IRB 120-3/0.6	R121 ⁱ	R580	R169.4

ⁱ Minimum turning radius axis 1.

Robot motion

The table specifies the types and ranges of motion in every axes.

Location of motion	Type of motion	Range of movement
Axis 1	Rotation motion	+165° to -165°
Axis 2	Arm motion	+110° to -110°
Axis 3	Arm motion	+70° to -110°
Axis 4	Wrist motion	+160° to -160°
Axis 5	Bend motion	+120° to -120°
Axis 6	Turn motion	+400° to -400° (default) +242 revolutions to -242 revolutions maximum ⁱ

ⁱ The default working range for axis 6 can be extended by changing parameter values in the software. Option 610-1 Independent axis can be used for resetting the revolution counter after the axis has been rotated (no need for "rewinding" the axis).

1.8.2 Performance according to ISO 9283

General

At rated maximum load, maximum offset and 1.6 m/s velocity on the inclined ISO test plane, with all six axes in motion. Values in the table below are the average result of measurements on a small number of robots. The result may differ depending on where in the working range the robot is positioning, velocity, arm configuration, from which direction the position is approached, the load direction of the arm system. Backlashes in gearboxes also affect the result.

The figures for AP, RP, AT and RT are measured according to figure below.

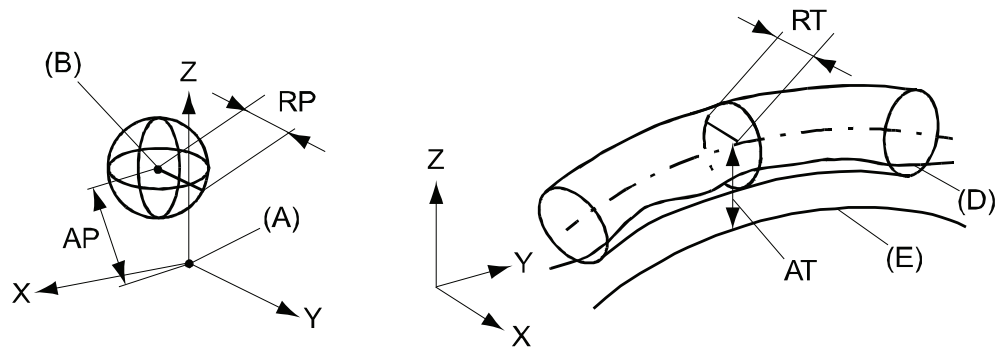

xx080000424

Position	Description	Position	Description
A	Programmed position	E	Programmed path
B	Mean position at program execution	D	Actual path at program execution
AP	Mean distance from programmed position	AT	Max deviation from E to average path
RP	Tolerance of position B at repeated positioning	RT	Tolerance of the path at repeated program execution

Description	Values
IRB	120 - 3/0.6
Pose repeatability, RP (mm)	0.01
Pose accuracy, AP ⁱ (mm)	0.02
Linear path repeatability, RT (mm)	0.07-0.16
Linear path accuracy, AT (mm)	0.21-0.38
Pose stabilization time, Pst (s) within 0.2 mm of the position	0.03

ⁱ AP according to the ISO test above, is the difference between the taught position (position manually modified in the cell) and the average position obtained during program execution.

The above values are the range of average test results from a number of robots

1 Description

1.8.3 Velocity

1.8.3 Velocity

General

Robot type	Axis 1	Axis 2	Axis 3	Axis 4	Axis 5	Axis 6
IRB 120 - 3/0.6	250 °/s	250 °/s	250 °/s	320 °/s	320 °/s	420 °/s

Supervision is required to prevent overheating in applications with intensive and frequent movements.

Resolution

Approx. 0.01° on each axis.

1.8.4 Robot stopping distances and times

Introduction

The stopping distances and times for category 0 and category 1 stops, as required by EN ISO 10218-1 Annex B, are listed in *Product specification - Robot stopping distances according to ISO 10218-1 (3HAC048645-001)*.

1 Description

1.9.1 Introduction to customer connections

1.9 Customer connections

1.9.1 Introduction to customer connections

General

The cables are integrated in the robot and the connectors are placed on the upper arm housing and one at the base. One connector R3.CP/CS on the upper arm housing. Corresponding connector R1.CP/CS is located at the base. Hose for compressed air is also integrated into the manipulator. There are 4 inlets at the base (R 1/8") and 4 outlets (M5) on the upper arm housing.

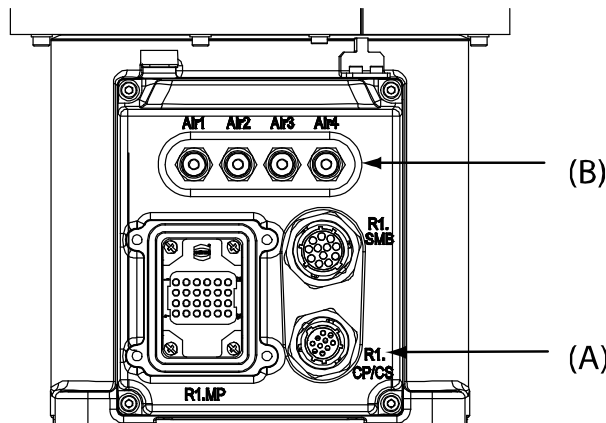
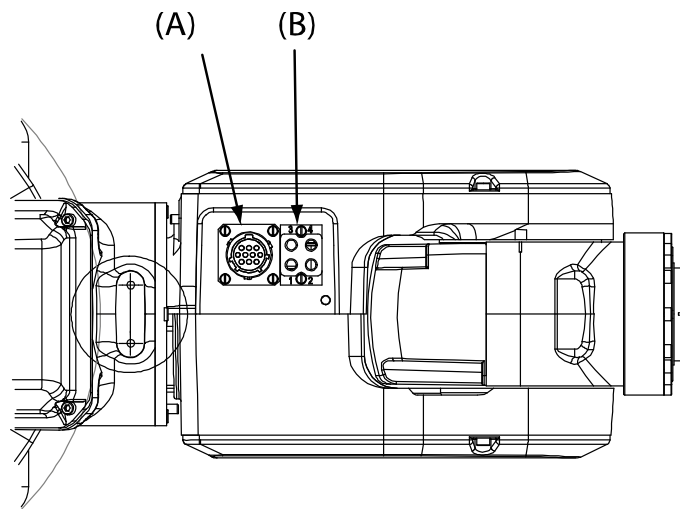

xx0900000264

Position	Connection	Description	Number	Value
A	(R1)R3.CP/CS	Customer power/signal	10	49 V, 500 mA
B	Air	Max. 5 bar	4	Inner hose diameter 4 mm

2 Specification of variants and options

2.1 Introduction to variants and options

General

The different variants and options for the IRB 120 are described in the following sections. The same option numbers are used here as in the specification form.

The variants and options related to the robot controller are described in the product specification for the controller.

2 Specification of variants and options

2.2 Manipulator

2.2 Manipulator

Variants

Option	Variant	Handling capacity (kg) / Reach (m)
435-100	Standard performance variant	IRB 120-3/0.6

Manipulator color

Option	Description	Note
209-1	ABB Orange standard	
209-2	ABB White standard	
209-202	ABB Graphite White standard	Standard color



Note

Notice that delivery time for painted spare parts will increase for none standard colors.

Protection class

Option	Description
287-4	Standard
287-1	Clean Room The robot is labelled with "Clean Room"

Lubrication

Option	Description
777-1	Manipulator lubricated with food grade lubrication.



Note

This option is released from RobotWare 6.03 as IRB120FGL-3/0.6.

Connector kit

Option	Description
431-1	For the connectors on the upper arm, customer connection.
239-1	For the connectors on the foot.

Warranty

Option	Type	Description
438-1	Standard warranty	Standard warranty is 12 months from <i>Customer Delivery Date</i> or latest 18 months after <i>Factory Shipment Date</i> , whichever occurs first. Warranty terms and conditions apply.

Continues on next page

2 Specification of variants and options

2.2 Manipulator Continued

Option	Type	Description
438-2	Standard warranty + 12 months	Standard warranty extended with 12 months from end date of the standard warranty. Warranty terms and conditions apply. Contact Customer Service in case of other requirements.
438-4	Standard warranty + 18 months	Standard warranty extended with 18 months from end date of the standard warranty. Warranty terms and conditions apply. Contact Customer Service in case of other requirements.
438-5	Standard warranty + 24 months	Standard warranty extended with 24 months from end date of the standard warranty. Warranty terms and conditions apply. Contact Customer Service in case of other requirements.
438-6	Standard warranty + 6 months	Standard warranty extended with 6 months from end date of the standard warranty. Warranty terms and conditions apply.
438-7	Standard warranty + 30 months	Standard warranty extended with 30 months from end date of the standard warranty. Warranty terms and conditions apply.
438-8	Stock warranty	<p>Maximum 6 months postponed start of standard warranty, starting from factory shipment date. Note that no claims will be accepted for warranties that occurred before the end of stock warranty. Standard warranty commences automatically after 6 months from <i>Factory Shipment Date</i> or from activation date of standard warranty in WebConfig.</p> <p> Note</p> <p>Special conditions are applicable, see <i>Robotics Warranty Directives</i>.</p>

2 Specification of variants and options

2.3 Floor cables

2.3 Floor cables

Manipulator cable length

Option	Lengths
210-1	3 m
210-2	7 m
210-3	15 m

Connection of parallel communication

Option	Lengths
94-6	3 m
94-1	7 m
94-2	15 m

2.4 Process

Process module

Option	Type	Description
768-1	Empty cabinet small	<i>Product specification - Controller IRC5 with FlexPendant</i>
768-2	Empty cabinet large	<i>Product specification - Controller IRC5 with FlexPendant</i>
715-1	Installation kit	<i>Product specification - Controller IRC5 with FlexPendant</i>

2 Specification of variants and options

2.5 User documentation

2.5 User documentation

User documentation

The user documentation describes the robot in detail, including service and safety instructions.

All documents can be found via myABB Business Portal, www.myportal.abb.com.

3 Accessories

3.1 Introduction to accessories

General

There is a range of tools and equipment available.

Basic software and software options for robot and PC

For more information, see *Product specification - Controller IRC5* and *Product specification - Controller software IRC5*.

Robot peripherals

- Motor Units¹

¹ Not applicable for IRC5 Compact controller.

This page is intentionally left blank

Index

A

Absolute Accuracy, 30
MultiMove, 31
accessories, 45

C

calibration
standard type, 28
category 0 stop, 37
category 1 stop, 37
compensation parameters, 30

D

documentation, 44

I

instructions, 44

M

manuals, 44

O

options, 39

P

product standards, 13

S

safety standards, 13
service instructions, 44
standards, 13
EN, 13
EN IEC, 13
EN ISO, 13
standard warranty, 40
stock warranty, 40
stopping distances, 37
stopping times, 37

U

user documentation, 44

V

variants, 39

W

warranty, 40



ABB AB, Robotics

Robotics and Motion

S-721 68 VÄSTERÅS, Sweden

Telephone +46 (0) 21 344 400

ABB AS, Robotics

Robotics and Motion

Nordlysvegen 7, N-4340 BRYNE, Norway

Box 265, N-4349 BRYNE, Norway

Telephone: +47 22 87 2000

ABB Engineering (Shanghai) Ltd.

Robotics and Motion

No. 4528 Kangxin Highway

PuDong District

SHANGHAI 201319, China

Telephone: +86 21 6105 6666

ABB Inc.

Robotics and Motion

1250 Brown Road

Auburn Hills, MI 48326

USA

Telephone: +1 248 391 9000

abb.com/robotics