

YuMi® creating an automated future together You and Me

YuMi heralds a new era of robotic co-workers which are able to work side-by-side on the same tasks as humans while still ensuring the safety of those around it.

Collaboration

YuMi is the first truly collaborative dual armed robot, designed for a world in which humans and robots work together. Intentionally designed to resemble its human counterparts to be friendly and non-threatening with a compact, dual-arm body which requires no more space than a human workstation.

YuMi harnesses the enormous potential of human-robot collaboration in small parts assembly. YuMi offers manufacturers a transformational new solution, the first dual arm robot purpose-built for the small parts space: inherently safe, extremely accurate.

Each magnesium arm flexes on seven axes to mimic human-like movements with spatial efficiency. The robot was specifically designed to meet the flexible and agile production needs required by the consumer electronics industry.

Thanks to its dual-arms, flexible hands, universal parts feeding system, camera-based part location and state-of-the-art motion control, YuMi has equal application in any small parts assembly environment.



Redefining safety

YuMi represents a dramatic shift in how industrial robots operate.

At its core, YuMi has the DNA of safety. Much like a human arm has a skeleton covered with muscles that provide padding, YuMi has a lightweight yet rigid magnesium skeleton covered with a floating plastic casing wrapped in soft padding. This arrangement absorbs the force of any unexpected impacts to a very high degree. Like the human arm, YuMi has no pinch points so that sensitive ancillary parts cannot be crushed between two opposing surfaces as the axes open and close.

If YuMi senses an unexpected impact, such as a collision with a coworker, it can pause its motion within milliseconds, and the motion can be restarted again as easily as pressing play on a remote control. Additionally, the robot can rapidly diagnose changes in its environment and, if necessary, register the overload, shutting down YuMi's motion within milliseconds to prevent injury. When this is combined with the floating padding, safety for a human coworker is drastically increased. Even with these inherent safety features, YuMi is incredibly precise and fast, returning to the same point in space over and over again to within 0.02 mm accuracy and moving at a maximum velocity of 1,500 mm/sec.

This revolutionary integration of speed, agility and sensory advantage ensures the safety of human coworkers on production lines and in fabricating cells.

Innovative technology by design

In addition to being a global leader in the manufacture of industrial robots, ABB Robotics also develops software and manufactures hardware, peripheral equipment, process equipment and modular manufacturing cells. This “total solution” concept is evident in YuMi’s breakthrough design.

While designed specifically for the electronics industry, YuMi is also well suited to other small parts environments, including the manufacture of watches, toys and automotive components. These end-markets have been changing faster than the process improvements they demand – until now.

Features

- The fifth-generation, integrated IRC5 controller with TrueMove and QuickMove™ motion control technology commands accuracy, speed, cycle-time, programmability and synchronization with external devices.
- I/O interfaces include Ethernet IP, Profibus, USB ports, DeviceNet™, communication port, emergency stop and air-to-hands. YuMi accepts a wide range of HMI devices including ABB’s teach pendant, industrial displays, commercially available tablets and smartphones.
- The 100-240 volt power supply plugs into any power socket for worldwide versatility.

Benefits

- Can operate equally effectively side-by-side or face-to-face with human coworkers.
- Servo grippers (the “hands”) include options for built-in cameras
- Real-time algorithms set a collision-free path for each arm customized for the required task.
- Padding protects coworkers in high-risk areas by absorbing force if contact is made.
- If the robot encounters an unexpected object – even a slight contact with a coworker – it can pause its motion within milliseconds, and the motion can be restarted again as easily as pressing play on a remote control.
- Pinch points have been eliminated or minimized to an acceptable level between moving parts, and between moving and stationary parts.

Specification

Robot Version	Reach	Payload	Armload
IRB 14000-0.5/0.5	500 mm	500 g	No armload

Features

Integrated signal and power supply	24V Ethernet or 4 Signals
Integrated air supply	1 per Arm on tool Flange (4 Bar)
Integrated ethernet	One 100/10 Base-TX ethernet port/per arm
Position repeatability	0.02
Robot mounting	Table
Degree of protection	IP30
Controllers	Integrated

Safety specification

Functional safety	PL b Cat B
-------------------	------------

Movement

Axis movement	Working range	Maximum speed
Axis 1 rotation	-168.5° to 168.5°	180°/s
Axis 2 arm	-143.5° to 43.5°	180°/s
Axis 3 arm	-123.5° to 80.0°	180°/s
Axis 4 wrist	-290.0° to 290.0°	400°/s
Axis 5 bend	-88.0° to 138.0°	400°/s
Axis 6 turn	-229.0° to 229.0°	400°/s
Axis 7 rotation	-168.5° to 168.5°	180°/s

Physical order of the axis is 1,2,7,3,4,5,6

Performance

0.5 kg picking cycle	
25* 300 * 25 mm	0.86s
Max TCP Velocity	1.5 m/s
Max TCP Acceleration	11 m/s²
Acceleration time 0-1m/s	0.12s

Physical

Total bottom	399mm * 496mm
Toes	399mm * 134mm
Weight	38kg

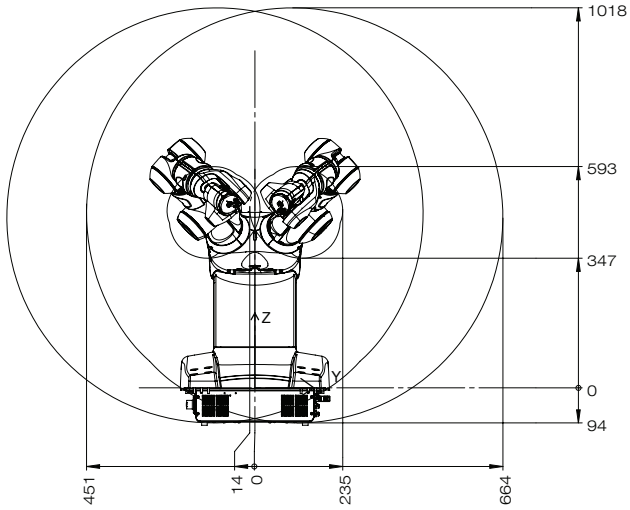

IRB 14000-0.5/0.5 Front view

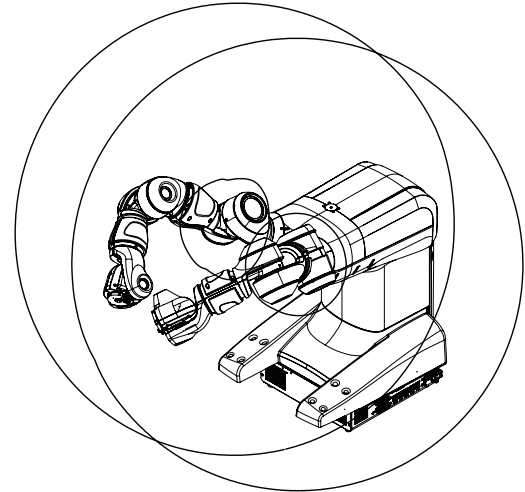

IRB 14000-0.5/0.5 Isometric view

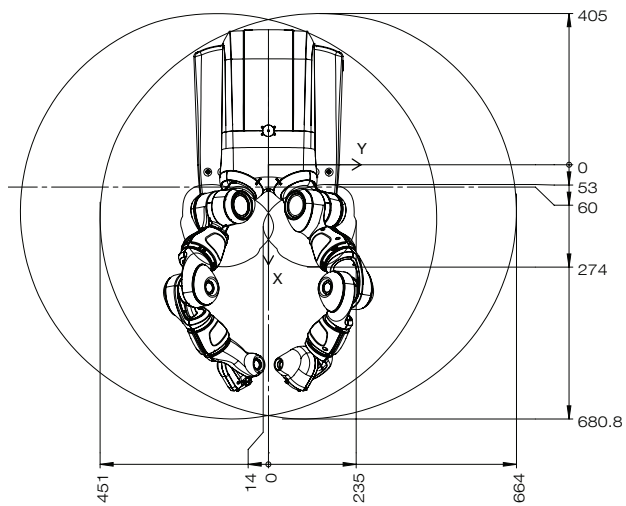

IRB 14000-0.5/0.5 Top view

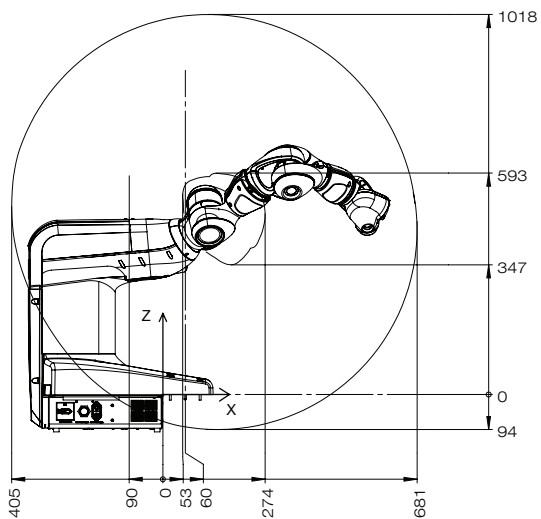

IRB 14000-0.5/0.5 Side view

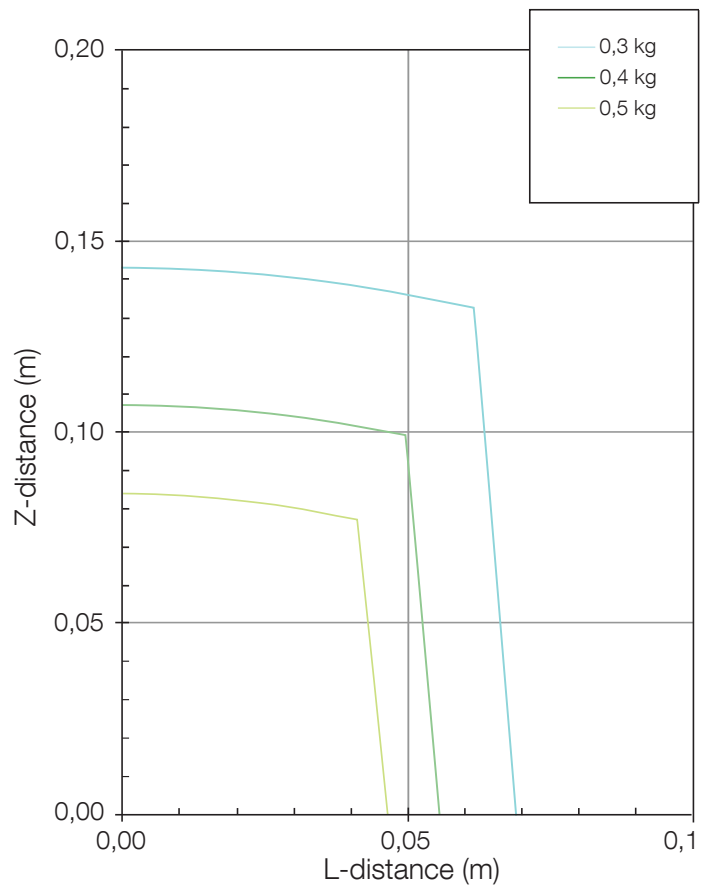

Load range

For more information please contact:

ABB Engineering (Shanghai) Ltd.

Robotics

No. 4528 Kangxin Highway,
Pudong New District
201319, Shanghai, China
Phone: +86 21 6105 6666

www.abb.com/robotics

Please note:

We reserve the right to make technical changes to the product and to the information in this document without notice. The agreed conditions at the time of the order shall apply. ABB assumes no responsibility for any errors or omissions that may appear in this document. We reserve all rights in this document and in the information contained therein. Without prior written approval from ABB, reproduction, disclosure to third parties or use of any information, in whole or in part, is strictly forbidden.

Copyright© 2015 ABB, all rights reserved